

AM · FM · TELEVISION

BROADCAST

NEWS

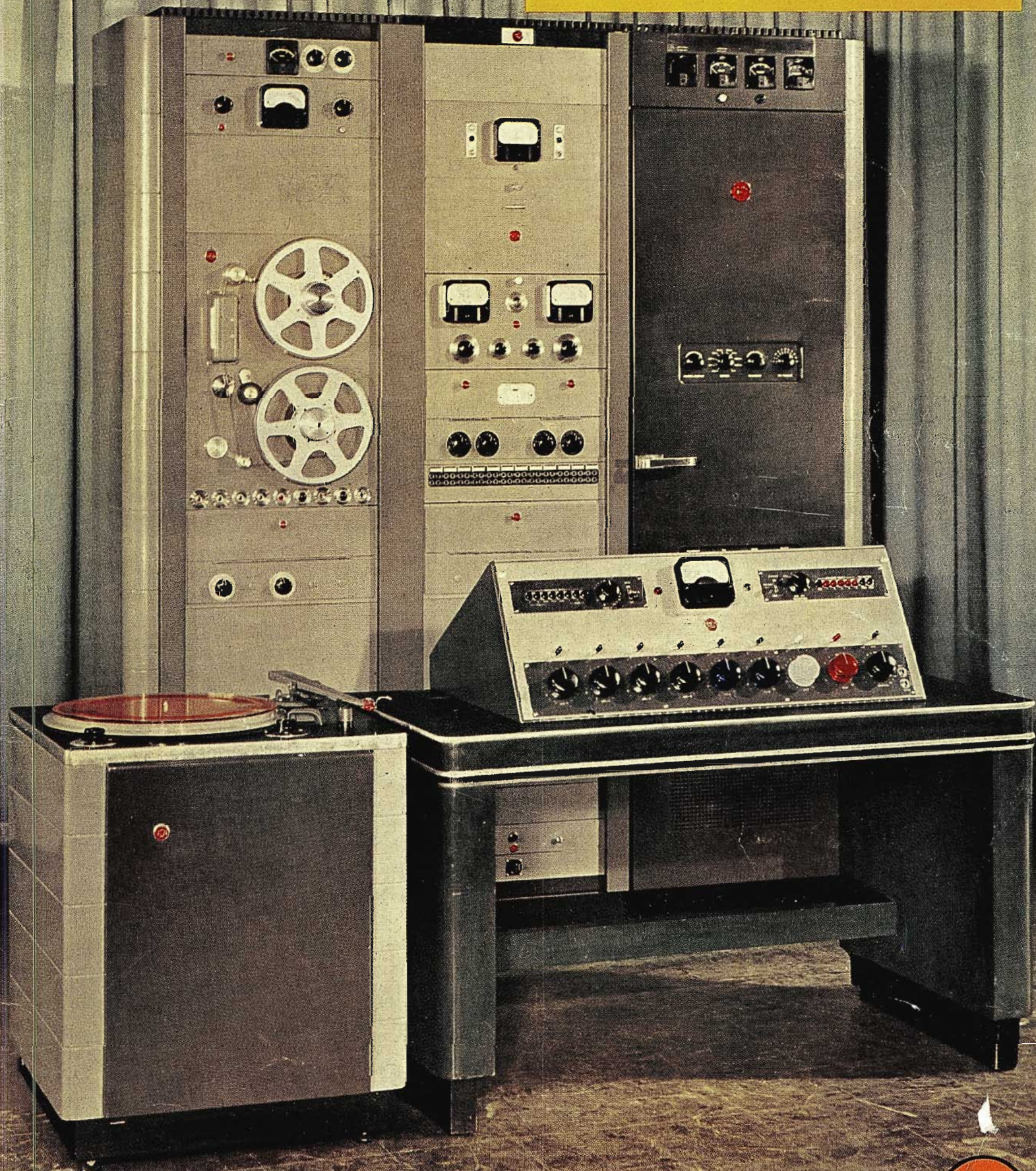

NEW EQUIPMENT FOR AM . . . See Pg. 8

KOMO





IT'S UNOBTUSIVE. Umber gray coloring blends it right into the TV picture. Minimum reflection.

In the show . . . without stealing the act

RCA's new ribbon-pressure **"STARMAKER"** *

SO SLIM YOU MUST LOOK sharply to see it . . . so skillfully styled its shape and coloring fade right into the scene . . . this tubular microphone has won the favor of entertainers and announcers wherever it has been shown.

Designed by RCA Laboratories after more than three years of painstaking research, the STARMAKER meets the long need of broadcasting, television, and show business for a high-fidelity microphone that—will not hide the features of performers—is easier to handle—and yet retains all the high-quality features of RCA professional microphones. Pick-up is non-directional. Frequency response is uniform, 50 to 15,000 cps.

Here is a "carry-around" microphone free from wind blast and air rumble. It contains no tubes, no condensers, no high-impedance circuits, no special amplifiers, or power supplies—is virtually impervious to mechanical shock.

The STARMAKER fits any standard microphone stand . . . and can be substituted for any professional high-quality RCA microphone. *No extra attachments needed!*

For price and delivery, call your RCA Broadcast Sales Engineer. Or write Dept. 7K, RCA Engineering Products, Camden, N. J.

**Selected from entries submitted by Broadcast Stations in national contest.*



IT'S COMFORTABLE TO HANDLE . . . weighs only 1 lb.

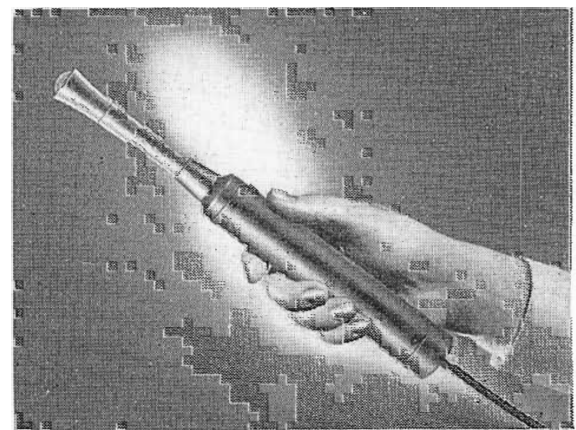

IT'S SMALL. Diameter of body is only 1¼ inches. Diameter of pick-up point is only ⅜ inch!



AUDIO BROADCAST EQUIPMENT
RADIO CORPORATION of AMERICA
ENGINEERING PRODUCTS DEPARTMENT, CAMDEN, N. J.

In Canada: RCA VICTOR Company Limited, Montreal

Broadcast News

AM • FM • TELEVISION

Published by the

RADIO CORPORATION OF AMERICA

ENGINEERING PRODUCTS DEPARTMENT . . . CAMDEN, NEW JERSEY

NUMBER 63

MARCH-APRIL, 1951

Subscription Rates

In continental U. S. A. - \$4.00 for 12 issues
 In other countries - - - \$5.00 for 12 issues

JOHN P. TAYLOR, Editor

W. O. HADLOCK, Managing Editor

M. L. GASKILL, E. B. MAY, Associate Editors

Contents

NEW LIMITING AMPLIFIER, BA-6A	by G. A. SINGER	4
ALL NEW 250-WATT AM TRANSMITTER	by R. J. NEWMAN	8
WDSU, AM-FM-TV	by THE WDSU ENGINEERING STAFF	16
A VERSATILE VIDEO SPECIAL EFFECTS SYSTEM	by E. M. GORE	30
KRNT 709-FOOT TV TOWER UNDER CONSTRUCTION		34
THE REQUIREMENTS OF TELEVISION STATION DESIGN (PART III)	by DR. WALTER J. DUSCHENSKY	36
FACTORS AFFECTING PERFORMANCE OF DIRECTIONAL ANTENNAS	by A. EARL CULLUM, JR.	43
RCA BROADCAST SALES EXECUTIVES		52
RCA BROADCAST FIELD SALES REPRESENTATIVES		54
MORE BASEBALL TELEVISION	by JOHN P. TAYLOR	57
A PROFESSIONAL TAPE RECORDER	by W. E. STEWART	66
TWO NEW STUDIO CONSOLETES	by DAVID BAIN	74

Copyright 1951
 Radio Corporation of America
 RCA Victor Division
 Camden, N. J.

PRINTED
 IN
 U.S.A.

OUR COVER shows the new RCA 250-watt AM Transmitter—which is standard rack size—sembled with two racks of associated audio and monitoring gear to form a neat transmitter control room package. On the table in front is the new BC-2B Audio Console. This picture was made in our transmitter lab by Rod Allen, our staff photographer.

NEW AM EQUIPMENT, practically across the board, is our big story at NAB this year. We have a whole new line of AM Transmitters—including a 250-watt, a one-kilowatt and a five/ten kilowatt. And they are not just small modifications of the same old thing! In fact, every one of them is a completely new—and radically different design. Compactness and economy of operation is the keynote. For an eye-opener in this respect, see them in our booth.

In addition to new AM Transmitters, we have a new line of AM monitors (frequency and modulation), two new audio consolettes, and other new audio items.

The new 250-watt transmitter is described in the article by Dick Newman which begins on Page 8. The audio consolettes are very briefly described by Dave Bain on Page 74. These and other new items will be described at greater length in the next issue.

NEW TV TRANSMITTERS, in powers which give you a wide choice of transmitter-antenna combinations, are also on display. To our original 500-watt and 5000-watt models we've added new 2000-watt and 20,000-watt units. Thus you can get an ERP (effective radiated power) of anything from 1 kw to 200 kw very easily. In smaller stations it will be possible to get the desired power in two, or more, ways (i.e., low-power transmitter plus high-gain antenna or higher power transmitter plus lower-gain antenna). Choice will depend on antenna limitations, future expansion plans, etc. Either way, we have what you need.

DIRECTIONAL ANTENNA PERFORMANCE depends to a surprising degree on the care with which the antenna system elements (meaning towers, lines, ground system, etc.) are installed. If the pattern is at all "critical" it will be worthwhile to carefully plan and painstakingly install the system in accordance with certain well-proved methods. The consulting firm of A. Earl Cullum, Jr., has a long record of outstanding accomplishment in the field of directional arrays. Some of their thinking in regard to the manner in which the various antenna elements should be installed is incorporated in the article beginning on Page 43. This material was first presented by Mr. Cullum at the NAB Engineering Conference in 1948. It is, therefore, not strictly new. However, it has not been published previously and we felt, therefore, that we would be doing a real service by making it available to all our readers.

OUR FIELD REPRESENTATIVES all get their pictures in this issue (see Page 54) in honor of the NAB Convention. Most have been in before—but we present them again because we want you who may not know them to get acquainted with them. And those of you who already know them, to remember them when you have equipment problems. These men are experts on every phase of station equipment. They can be your surest source of up-to-date information—information you can rely on in every respect. Remember—they have a twenty-two year tradition of helpfulness, courtesy and reliability!



RCA

Announces

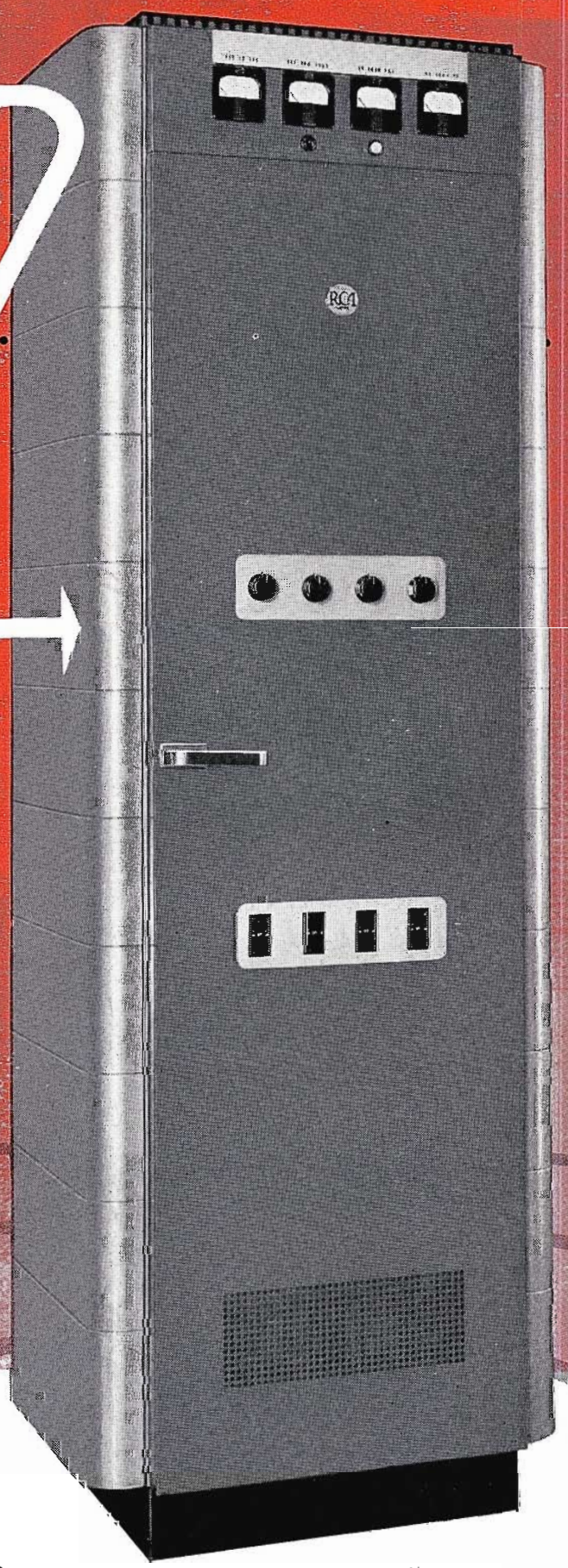

RCA
Type BTA-250M
250-Watt AM Transmitter

\$ SMALLER SIZE
—Same size as an audio rack

\$ TAKES LESS POWER
1000 watts, approximately, unmodulated

...an all-new 250-watt AM transmitter

A new concept in operating efficiency . . . a major advancement in plant economy

\$ BETTER FREQUENCY STABILITY
—maximum deviation, ± 5 cycles per second

**\$ NO NEUTRALIZATION
REQUIRED**

\$ FEWER TUBE TYPES
—only 3 types to stock

\$ HIGHER FIDELITY
30 to 10,000 cps. Does not exceed
2% distortion at 95% modulation.

\$ FEWER TUBES (lower tube costs)
—uses only 10 tubes

Get the complete facts about this revolutionary new 250-watt AM transmitter from your RCA Broadcast Sales Engineer. Or write Dept. RCA Engineering Products, Camden, New Jersey.



**BROADCAST EQUIPMENT
RADIO CORPORATION of AMERICA
ENGINEERING PRODUCTS DEPARTMENT, CAMDEN, N.J.**

in Canada: RCA VICTOR Company Limited, Montreal

NEW LIMITING AMPLIFIER, BA-6A

By **G. A. SINGER**
Audio Engineering Section

Operating Considerations

Since every system for the transmission, recording or reproduction of sound is capable of delivering only a limited amount of power, there will be a level at which the system or a unit of the system becomes overloaded or overmodulated. Under these

conditions, the output level is no longer a linear function of the input level and non-linear distortion takes place. To the ear, this is one of the most annoying forms of distortion and for this reason alone, overloading or overmodulation must be prevented if good reproduction is to be maintained.

Yet economic reasons, and the desire for a high signal-to-noise ratio, dictate that the system be operated as near maximum

output or full modulation as possible. Speech and music, however, vary widely and often suddenly in level. Manual means of adjusting output therefore cannot be relied upon entirely to prevent overloading or overmodulation at sudden peaks in the program. An automatic means of limiting output to a safe maximum value is therefore essential for the successful operation of every broadcasting station and recording studio.

In order to obtain distortionless limiting, a limiting amplifier is inserted at an appropriate point of the system. Its primary function is to reduce the system gain by nearly the same amount as the signal level is increased above a predetermined value while at the same time preserving the waveform.

A limiting amplifier must not only meet all of the specifications required of other audio amplifiers, such as frequency response, gain, power output, distortion, noise and stability, but many special specifications which are peculiar to its operation as a limiting amplifier.

Foremost of these is the compression characteristic. Up to a certain level, called the verge of limiting, the gain is constant and hence the output is proportional to the

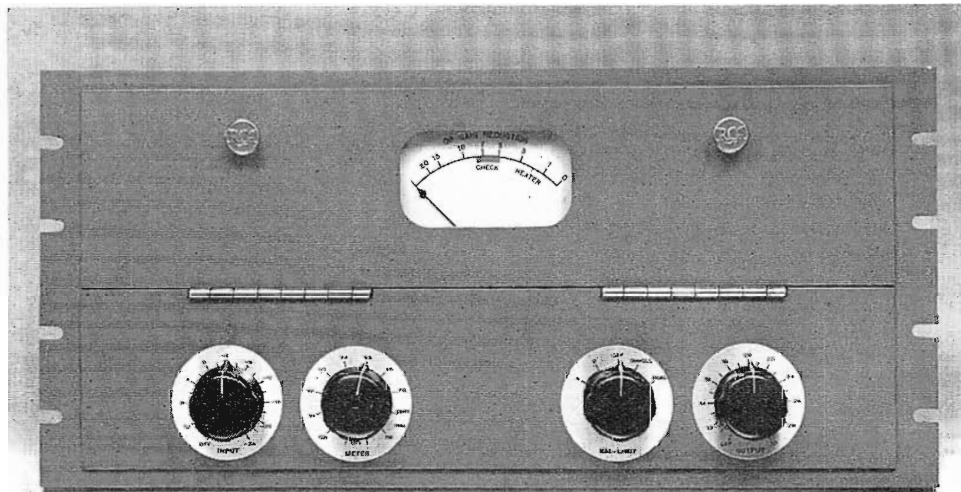

FIG. 1 (above). Front panel view of the new BA-6A Limiting Amplifier.

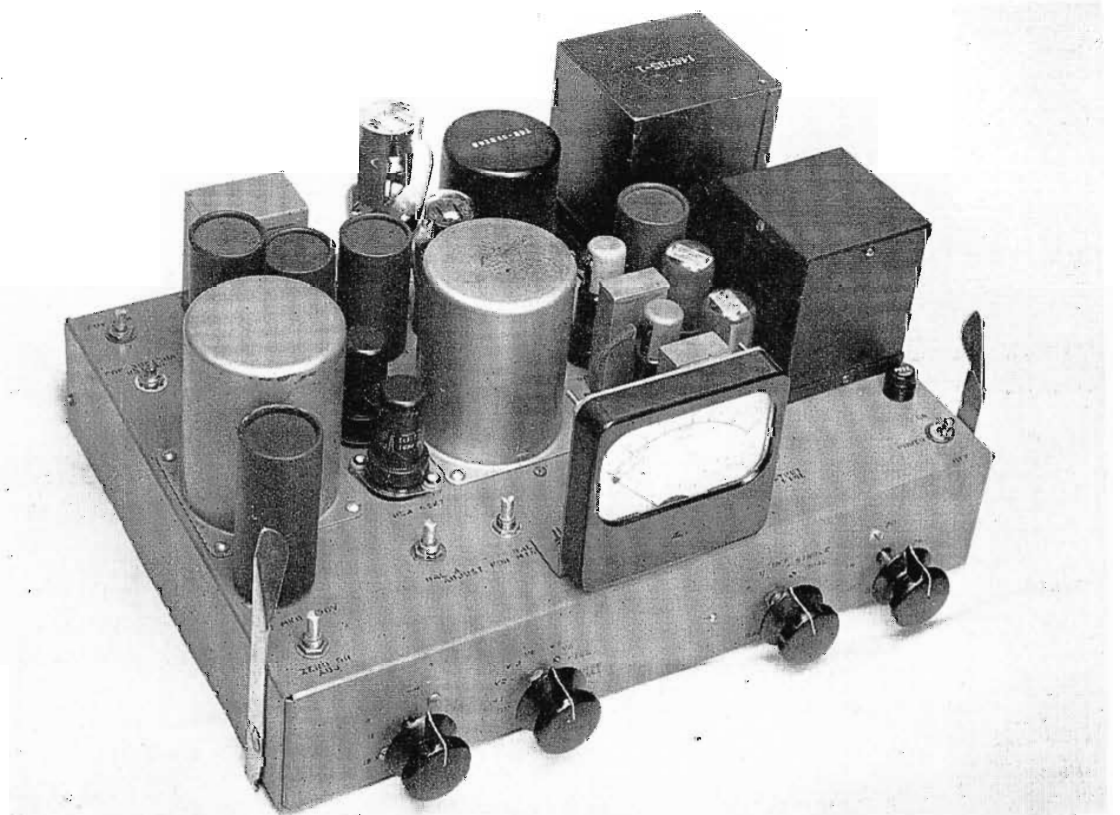

FIG. 2 (right). Chassis-view of limiting amplifier. Note plug-in amplifier design for shelf mounting which allows quick and easy removal.

input. Above the verge of limiting, the amplifier gain is progressively reduced. The difference between what the output would be at constant gain and what it is with reduced gain (due to limiting) is the gain reduction. The ratio of the increase in input level in db to the increase in output in db is the compression ratio.

Another important rating is the time required for a change in gain to take effect. The attack time (which is the time required for the gain to be reduced) should be as short as possible in order that compression be effective on a sudden peak. Listening tests, however, indicate no appreciable change in sound quality by making the attack time shorter than 1 millisecond. The recovery time, which is the time required for the gain to return to normal after the signal level has dropped below the verge of limiting must be fairly long in order to avoid distortion at low frequencies and to prevent rapid change in gain from becoming noticeable. The optimum recovery time depends on the type of program material.

Usually the operating point of a tube is shifted to change the gain of a limiting amplifier. The resulting change in plate current, unless balanced out will cause a "thump" (a low frequency transient) to appear in the output of the amplifier. The ratio of signal to "thump" should be maintained as high as possible over a wide range of gain reduction.

Amplifier Design and Operation

The operating principles of a modern limiting amplifier may be studied in greater detail by examining the BA-6A Limiting Amplifier which is newly designed for use in broadcast stations and recording studios. The BA-6A is a balanced, three stage amplifier which uses commonly available tube types as shown by the simplified schematic diagram of Fig. 3.

The input transformer matches a 600 or 150 ohm line. A dual attenuator controls the input signal which is applied to the control grids of two 6SK7 remote cut-off pentodes of the variable gain stage. To minimize thump over a wide range of gain reduction, both the screen and cathode voltages of these tubes are adjustable and thus any pair of tubes may be balanced over the entire operating range.

The balancing operation is simple. By setting a selector switch to the "Balance A" position, an in-phase signal is applied to the control grids of the 6SK7 tubes. The output voltage is indicated by a meter.

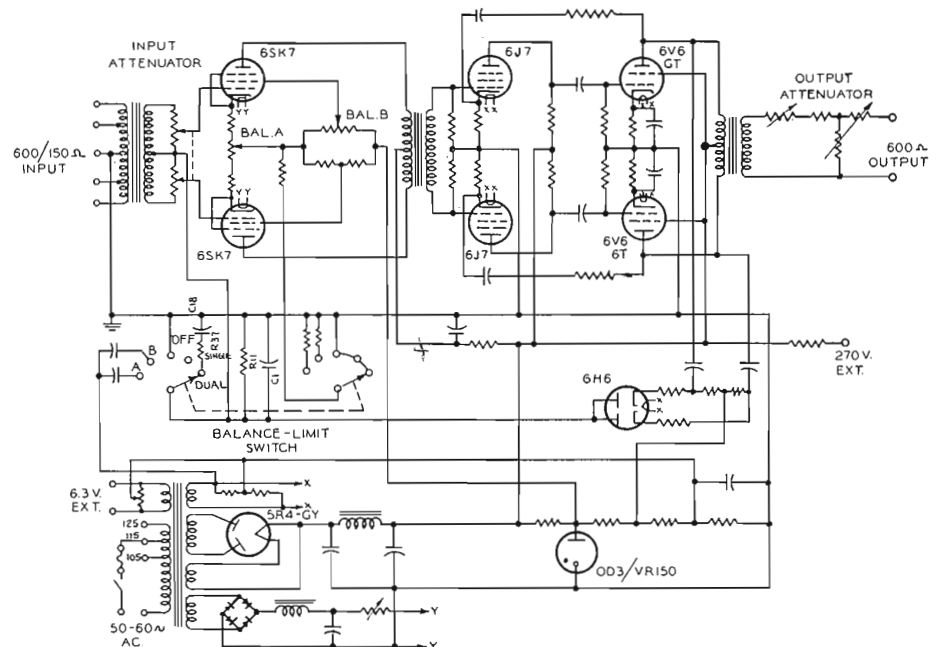

FIG. 3 (above). Schematic of the BA-6A which embodies simplicity of design with a total of only 9 tubes.

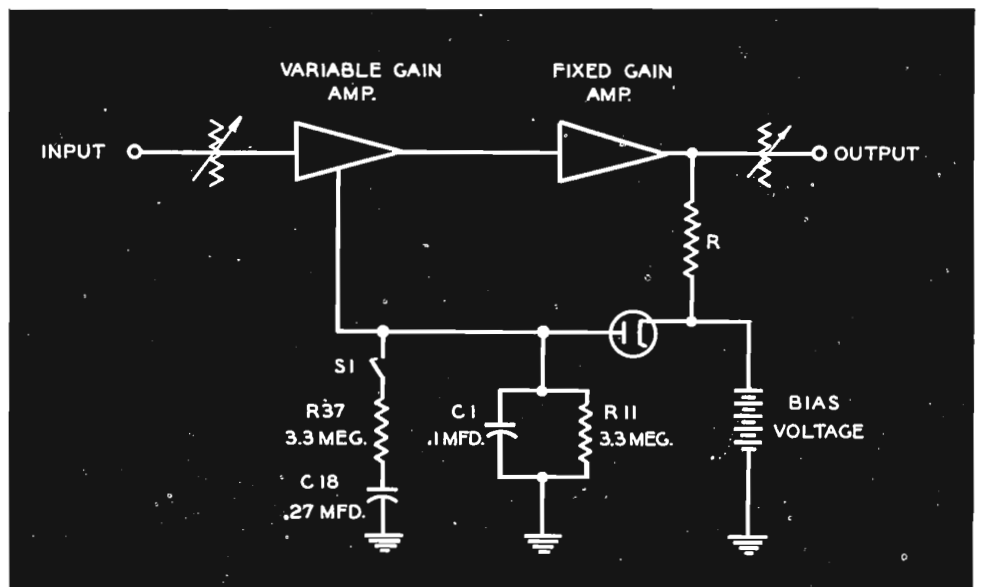

FIG. 4 (above). Block diagram of BA-6A Limiting Amplifier which employs a minimum of stages.

The "Balance A" control, which adjusts the cathode voltage of the two tubes is then adjusted for minimum output indication. By setting the selector switch to the "Balance B" position, a larger signal is applied to the control grids and the cathode bias is increased. The "Balance B" control, which sets the screen grid voltage of one of the 6SK7 tubes, is then adjusted for minimum output signal. This process is repeated until no output is indicated in both the Balance "A" and "B" positions. The characteristics of the tubes are then very closely matched over a wide

range of gain reduction which results in a high signal-to-thump ratio. This arrangement also permits periodic checks of tube balance and compensation for tube aging.

The screen supply-voltage of the variable gain stage is held constant by means of a voltage regulator tube and negative feedback is applied over the other two stages in order to obtain high stability of gain and output over wide variations in line voltage. To minimize hum, the heater current for the first stage is derived through a filter from a full-wave selenium rectifier.

INPUT & OUTPUT WAVE FORMS
BA-6A LIMITING AMPLIFIER

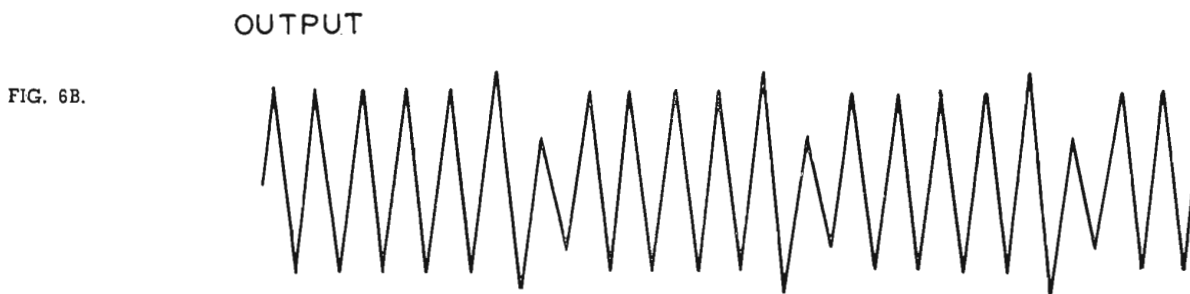
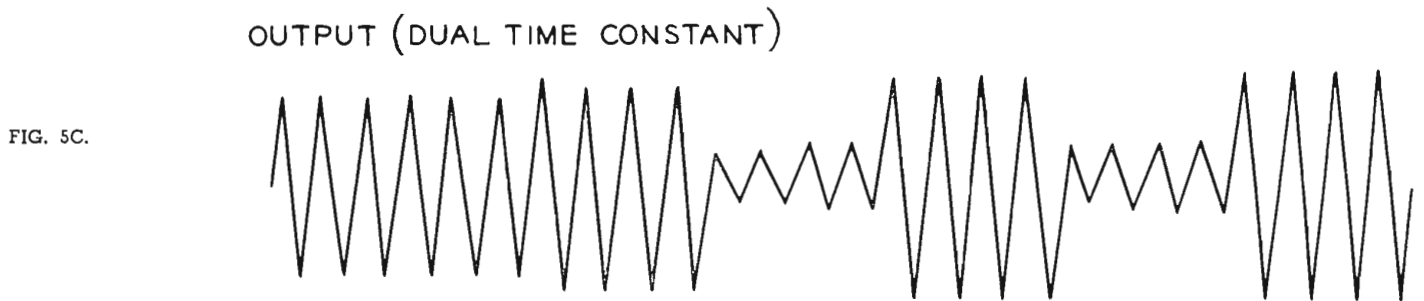
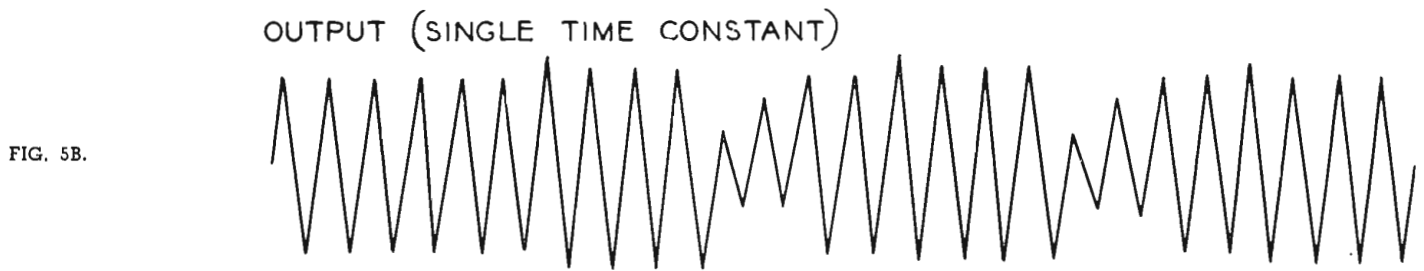
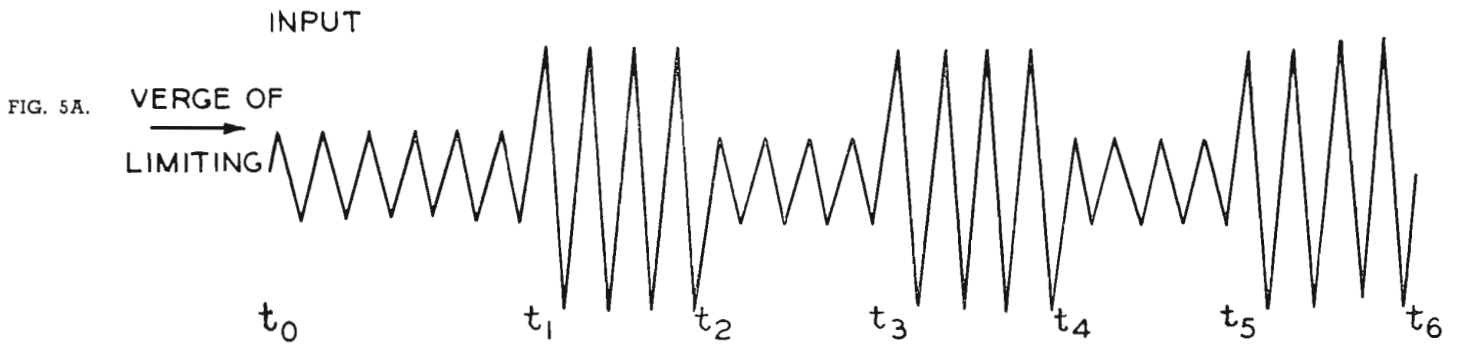

As an additional means of maintaining balance, the first stage is transformer coupled to the second stage. The output stage is capable of delivering 10 watts to a 600-ohm output attenuator which is calibrated in 1 db steps. A continuous fine output adjustment is also provided to set the output level exactly. This is as important a feature as stability of output because a fraction of a db change in output level may result in a large increase of distortion in certain types of equipment as for example, a transmitter.

A full wave rectifier, connected to the output stage through coupling capacitors and isolating resistors, provides the gain control voltage. The cathodes of the rectifier tube are biased positive with respect to the plates and the tube will not conduct until the output signal exceeds the limiting level. The rectified voltage is filtered by capacitors C1 and applied to the control grids of the tubes in the variable gain stage. The higher the output level tends to become, the more the gain is reduced. The compression ratio thus obtained is greater than 10 to 1.

The "limit-off" position on the selector switch is provided to turn the limiting action off when no compression is desired. The "single-limit" and "dual-limit" positions of the selector switch S1 determine the recovery time constants of the gain reduction circuit.

The single time constant is formed by the capacitor C1 and resistor R11. The capacity of C1 and the resistance of R11 are such that the capacitor will charge very rapidly (0.0006 sec.) and discharge more slowly (0.33 sec.). The dual time constant is obtained by connecting capacitor C18 and resistor R37 in series across the Capacitor C1. Capacitor C18 is slowly charged through R37 (0.9 sec.) and even more slowly discharged (2.0 sec.) through R37 and R11. The difference between the results obtained when using the single or dual time constant circuits are illustrated by the following examples:

Consider an input waveform as shown in Fig. 5A. From t_0 to t_1 the level corresponds to the verge of limiting. At t_1 the level is suddenly increased. At t_2 the level is again decreased to what it was at t_0 , etc.

With the switch S1 in the single-limit position, the output waveform will be approximately that shown in Fig. 5B. Assuming the charging time of C1 to be much shorter than the period of the signal, the output signal will increase only slightly since the amplifier gain is reduced

as C1 is charged. At t_2 the output drops suddenly as the input level is reduced, but increases rapidly as the charge leaks off C1 and the gain is restored to normal.

With the switch S1 in the dual-limit position, the output waveform is the same as with S1 in the single-limit position up to t_2 . During the time interval from t_1 to t_2 , however, the capacitor C18 is charged. As the input level drops at t_2 , the output level drops as in the first case, but increases much more slowly since the discharge time of C18 is longer than that of C1. The output waveform is indicated by Fig. 5C.

On an input waveform containing short peaks such as shown in Fig. 6A, there is not sufficient time for C18 to charge appreciably and the circuit acts as though the switch S1 were in the single-limit position. The corresponding output waveform is shown in Fig. 6B.

Thus with the dual timing circuit, the recovery time is short after a single peak and long after a series of peaks. This means that the reduction of gain following a short peak is held to a minimum and does not cause a noticeable "hole" in the program. After a prolonged series of peaks, the recovery time is long, and rapid changes in gain often referred to as "breathing" or "pumping" are avoided.

In order to obtain the desired system performance, the input and output attenuators of the limiting amplifier have to be

properly set. With a given maximum input level, the setting of the input attenuator determines the gain reduction obtained. The maximum gain reduction which should be used is a compromise between the increase in average power output and the loss of dynamic range.

Listening tests indicate that as much as 15 to 20 db of gain reduction can be used on program material where the loudness range is not of primary importance. The output attenuator and fine output adjustment must be set for the desired output level or percentage modulation at maximum gain reduction.

The BA-6A Limiting Amplifier also incorporates those features which are found in other RCA high-quality broadcast audio amplifiers. The amplifier with its self-contained power supply is constructed on a plug-in chassis for shelf mounting and is therefore readily removable for inspection and service. All controls, tubes, and plug-in capacitors are accessible from the front. A selector switch permits use of the four-inch illuminated gain reduction meter for measuring the cathode current of all amplifier tubes, tube balance and d-c filament voltage. Plate and heater power are available for operating a pre-amplifier in applications where additional gain is required.

The use of high quality components and the straightforwardness of design, employing only 9 tubes including rectifier and voltage regulator, insure a maximum degree of reliability.

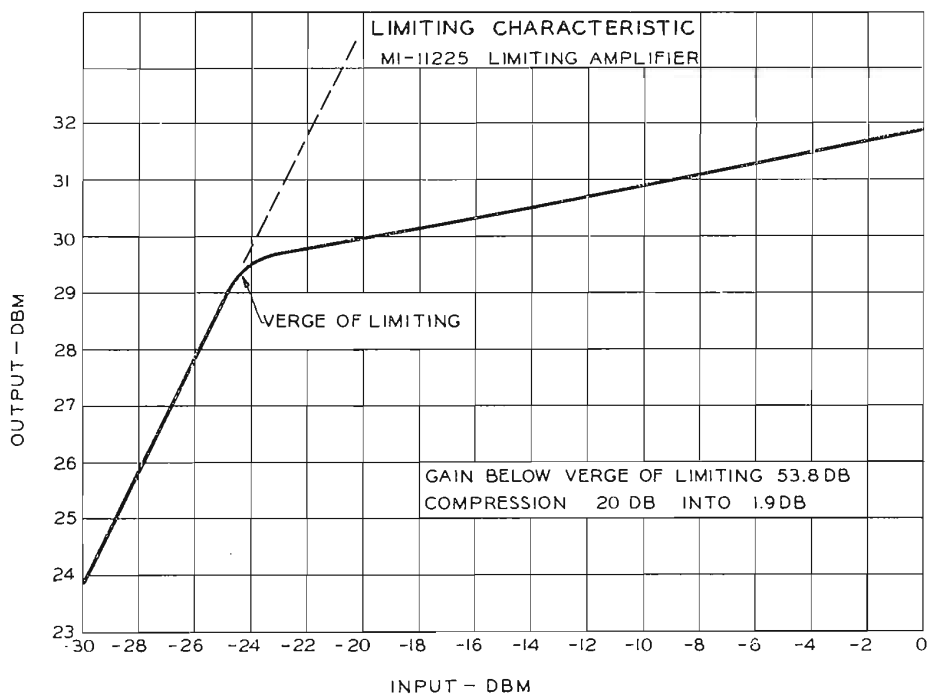
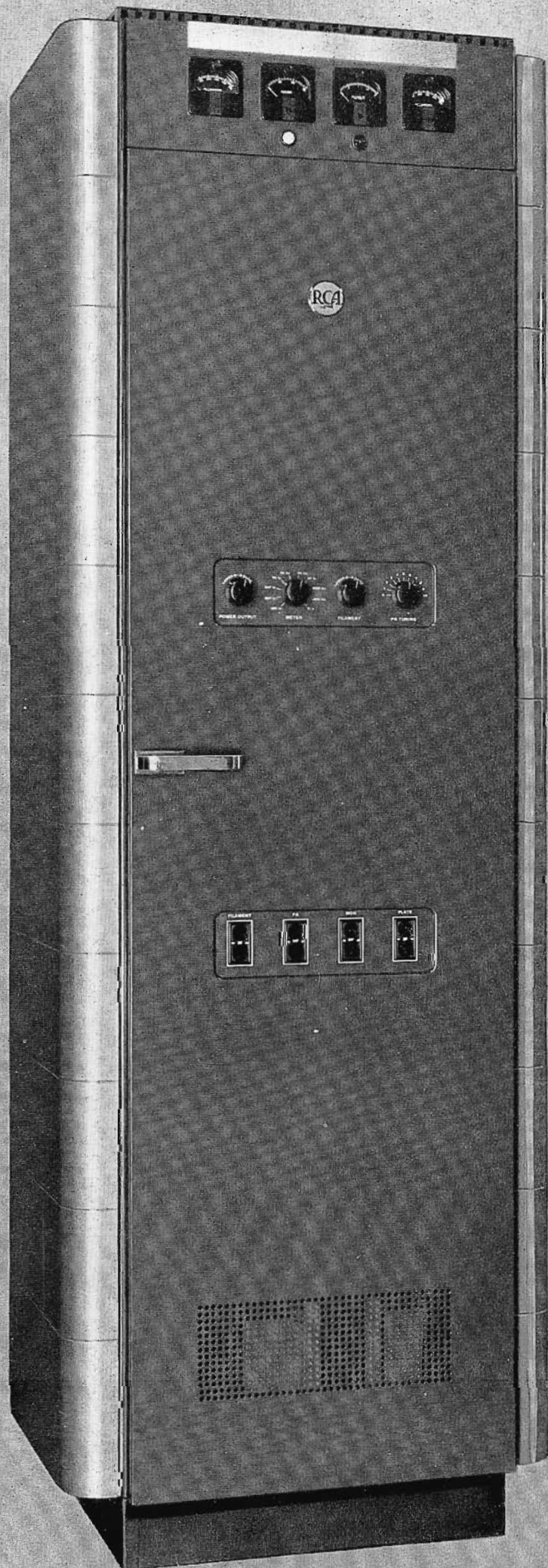

FIG. 7 (above). Curve of the limiting characteristic of the BA-6A. It provides an automatic means of limiting program output to a safe maximum value.



ALL NEW

By

R. J. NEWMAN

Product Manager,

Broadcast Transmitting Equipment

The RCA BTA-250M is a completely new 250-watt AM transmitter with advantages and features never before offered in a transmitter of this power. Several new techniques have been employed to produce a transmitter of smaller size, reduced weight, lower power consumption, fewer controls and lower tube cost. Other features of the new transmitter include: a fixed-tuned driver; circuits and tubes requiring no neutralization; and an improved modulation circuit resulting in better fidelity and lower distortion.

The BTA-250M retains the basic design philosophies for broadcast transmitters of this power, such as no fans, blowers or contactors to make noise; otherwise there is little similarity to previous designs.

Circuit Description

The BTA-250M employs a pair of 813 tubes in parallel as power amplifier, modulated by a pair of 813's operating class B. The oscillator employs the TMV-129B temperature-controlled crystal unit which maintains the frequency constant to within ± 5 cycles. Thus the frequency stability rating of ± 10 cycles, which has long been the standard for AM transmitters has been improved by a ratio of two to one. The output of the oscillator feeds a single RCA 807 tube operating as a buffer amplifier. The 807 buffer in turn drives the power amplifier.

New circuit design in the BTA-250M simplifies transmitter adjustment and operation. There is only one tuning control and one power output control in the entire transmitter. The tuning control is a vari-

This complete 250-watt AM transmitter is built into a new smaller cabinet exactly the size of an audio rack. Now this 250-watt transmitter can be installed in line with matching audio racks as emergency equipment.

250-WATT TRANSMITTER

- Fewer tubes and only three different types . . . all accessible at the front of the transmitter.
- Temperature-controlled crystal oscillator provides new standard of stability, ± 5 cycles.
- Only one tuning control . . . all controls accessible through openings in the front with the door closed.
- Only two tube-type rectifiers . . . others are proved selenium types.
- No air blowers needed . . . the BTA-250M generates very little heat —runs cool.

Open-door view of the BTA-250M, showing all the tubes and controls of the new transmitter. Four type 813 tubes, above the upper control panel, comprise the power amplifier and Class B modulator tubes.

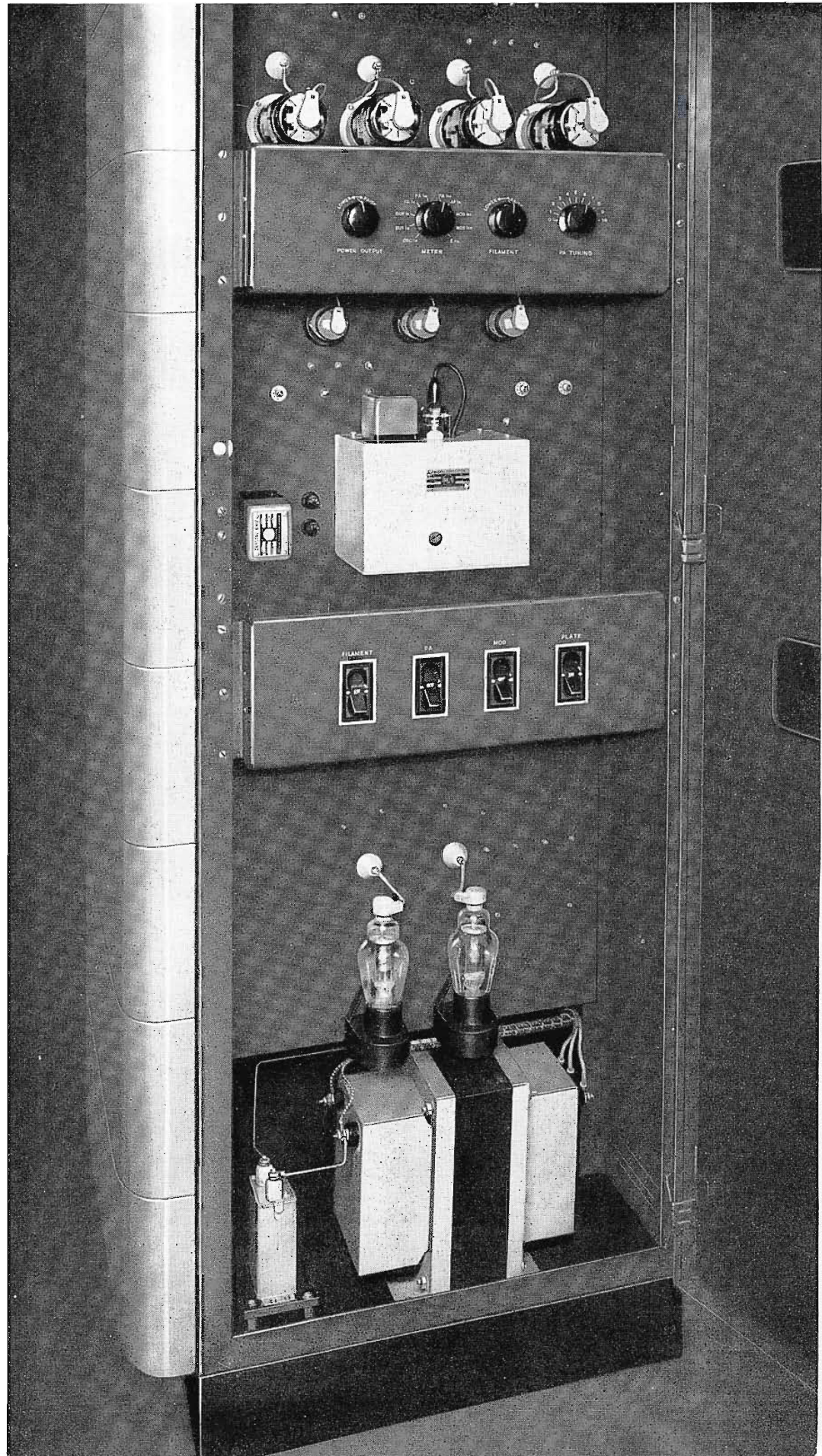

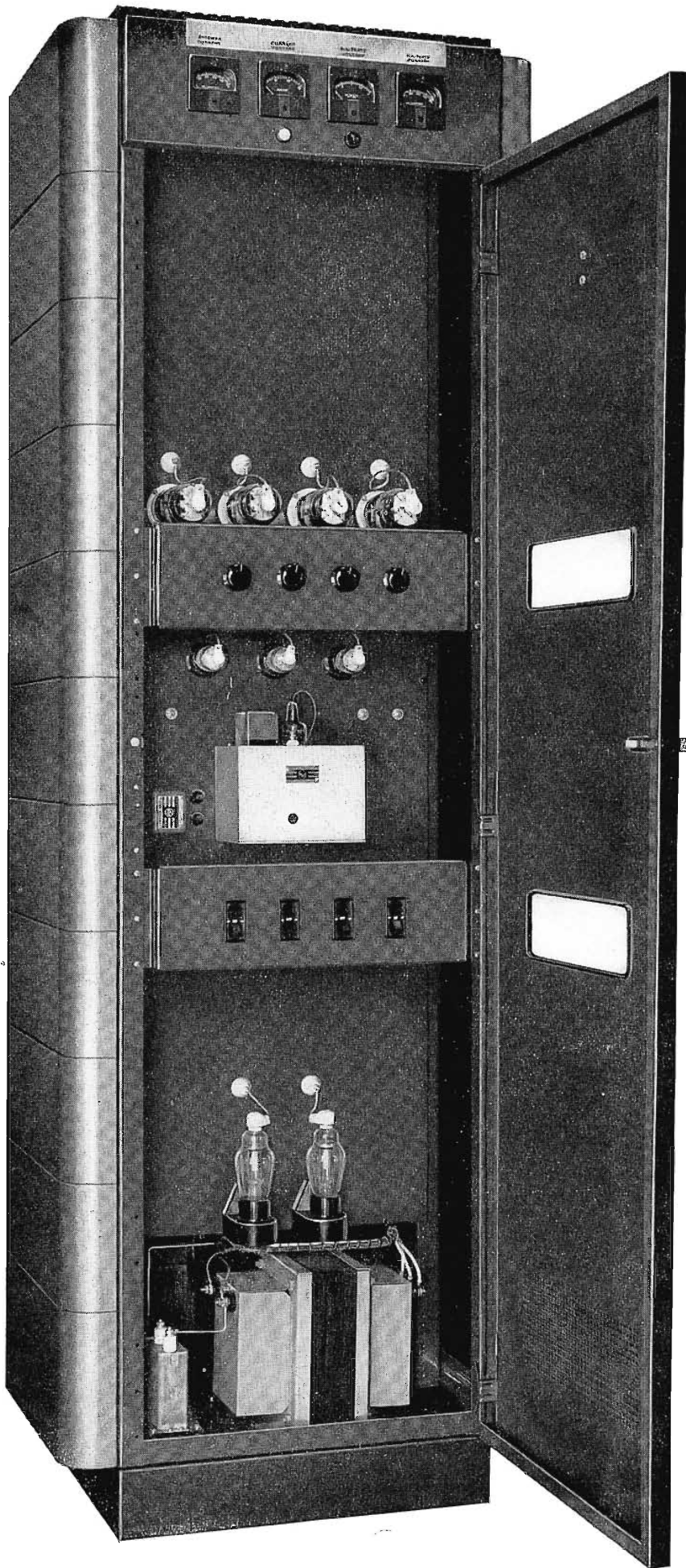

able capacitor in the plate circuit of the power amplifier, and the power output control is a variable resistor in the cathode circuit. For the low level r-f stages, the 807 crystal oscillator plate is broadly tuned by an inductor with suitable taps to cover the broadcast band. The 807 buffer plate is also broadly tuned for the entire broadcast band.

Greater PA Linearity

The plate circuit of the power amplifier is a single-sided load circuit to feed present-day unbalanced lines. Special design in the output network provides symmetrical loading both sides of carrier for the modulating sum and difference frequencies, and thus reduces distortion. A still further reduction in distortion is effected by modulation of the r-f drive to the power amplifier. This is done by modulating the buffer screen as well as the plates and screens of the PA. By applying modulating voltage to the buffer screens the PA is supplied with increased driving power during the modulating peaks when it is needed. Thus the PA is given the required drive during all portions of the audio cycle, greatly improving its linearity. As shown in the specifications for this transmitter, the distortion rating is 2% over a range from 50 to 10,000 cycles.

Highest Fidelity – Lowest Distortion

The audio section of the BTA-250M consists of two RCA-807 tubes in push-pull resistance coupled to the two class B 813 modulators. The modulation transformer secondary is tapped to provide modulation of the power amplifier plates and screens as well as the buffer screen, resulting in a very low order of distortion. Over 15 db of feedback is used to stabilize gain, avoid critical tube adjustments, and reduce hum and noise.

Only Two Tube-Type Rectifiers

A low voltage selenium rectifier supplies the plates and screens of the 807 tubes and the screens of the 813 tubes. Two RCA 866/866A rectifiers supply the plates of the modulator and PA tubes. Circuit protection is provided entirely by means of high speed magnetic circuit breakers. The circuit breakers also function as control

The entire BTA-250M is housed in an 84-inch cabinet. Most of the components are mounted on a single vertical chassis easily accessible from both the front and the rear. The four meters mounted in the upper front panel provide metering for all tubes in the transmitter.

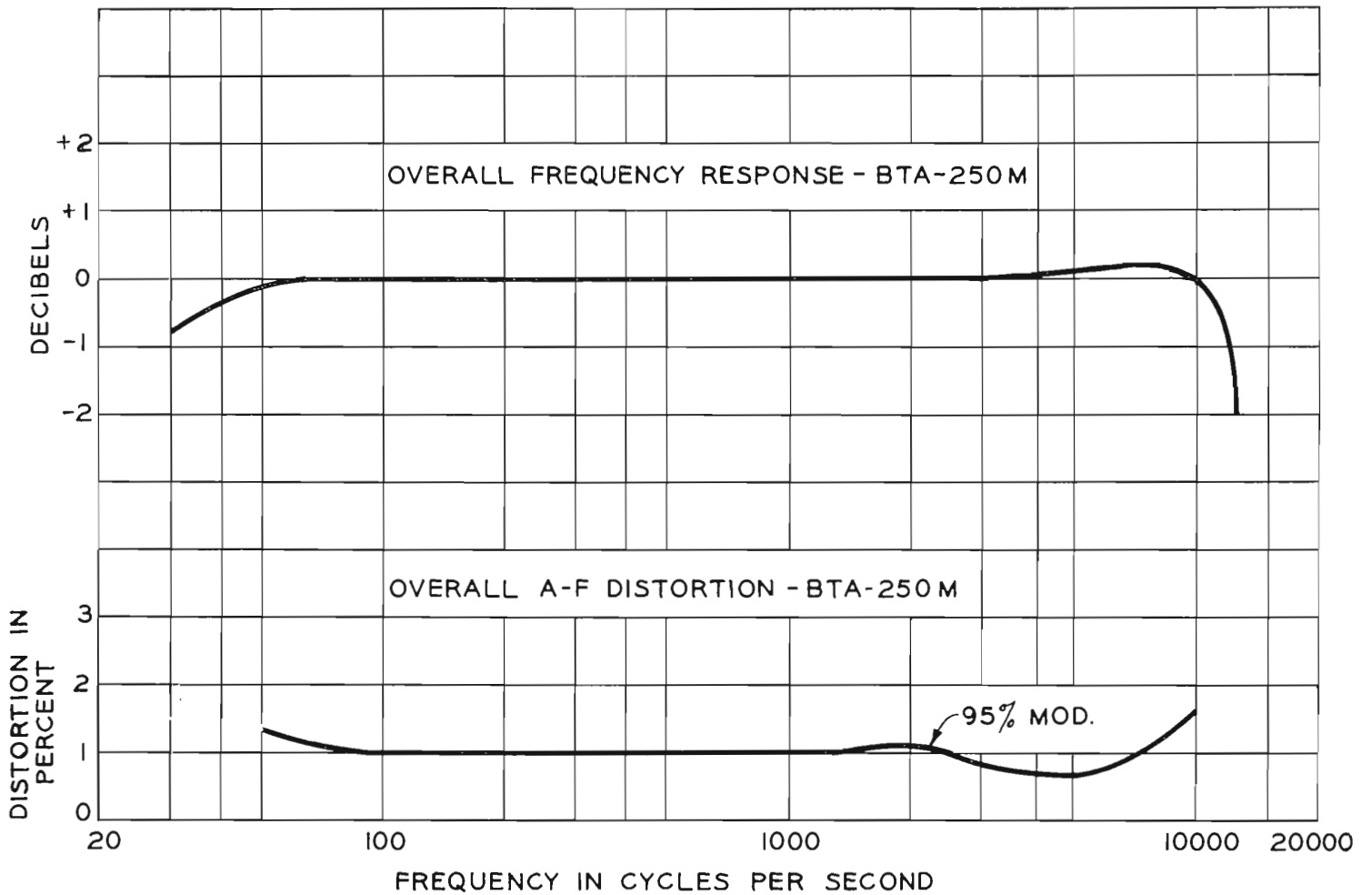

Actual response curves above show the improved fidelity and reduced distortion inherent in the BTA-250M.

NEVER SO MANY FEATURES IN A 250-WATT TRANSMITTER

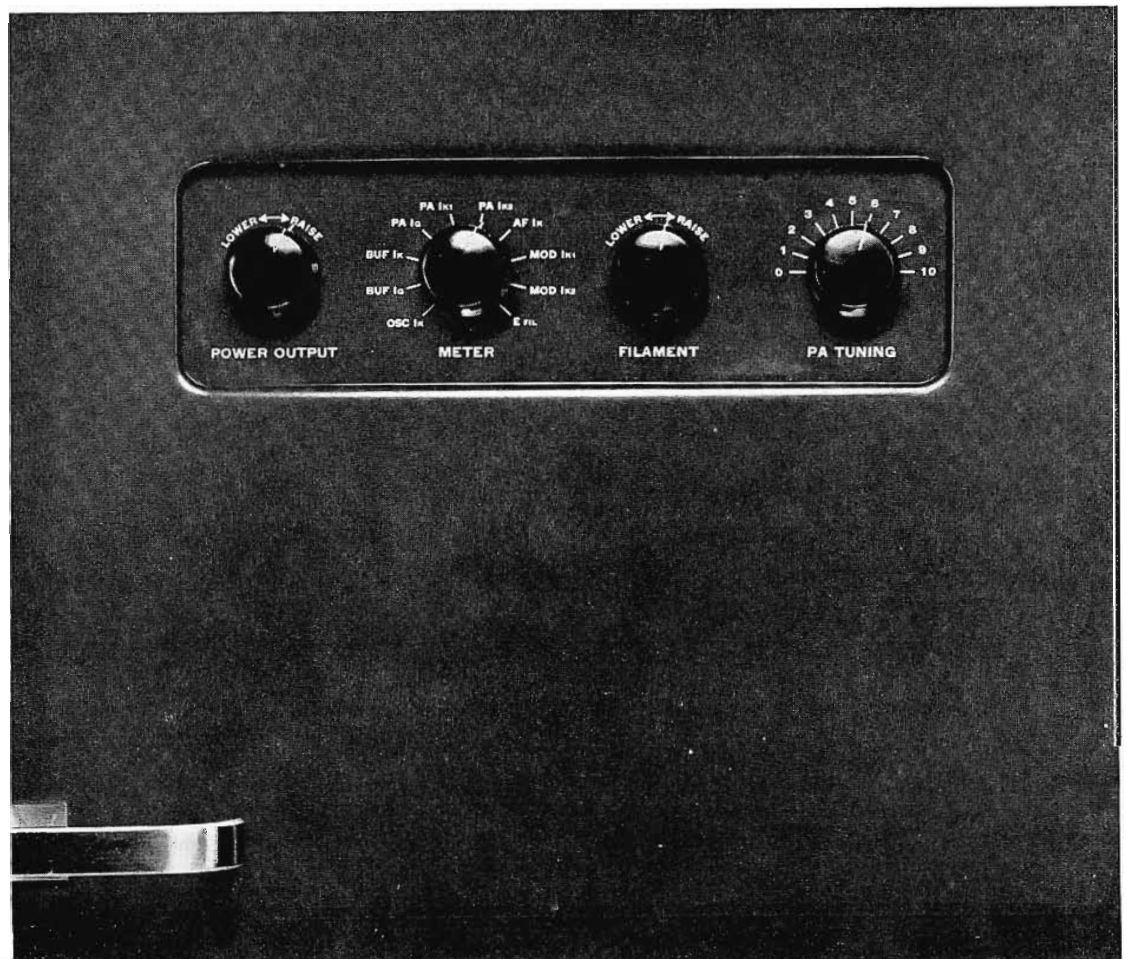

This is a closeup view of the control panel of the BTA-250M. These four knobs provide for complete control of power output, meter readings of each stage, tube filament voltage adjustment, and PA tuning. The power output control is shown schematically on the following page.

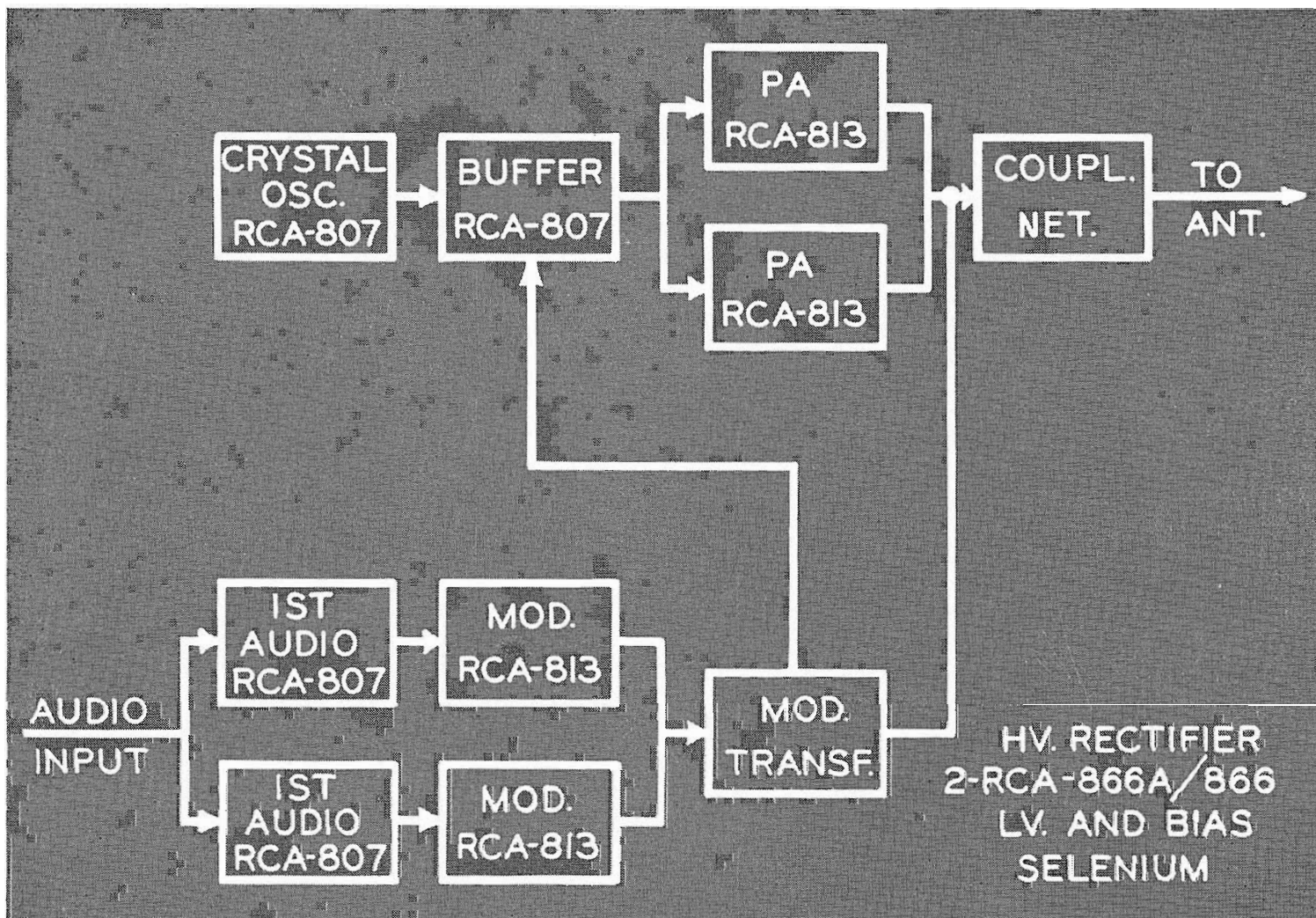

Overall block diagram of the new RCA 250-watt Transmitter.

Simplified schematic diagram below shows how modulation is applied to both buffer and final. Variable resistor R is the transmitter power output control.

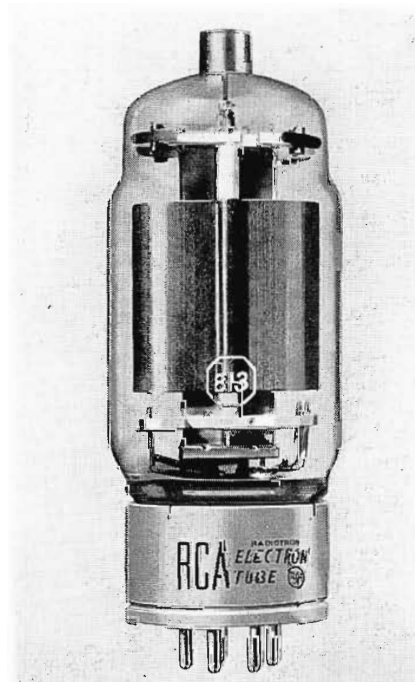
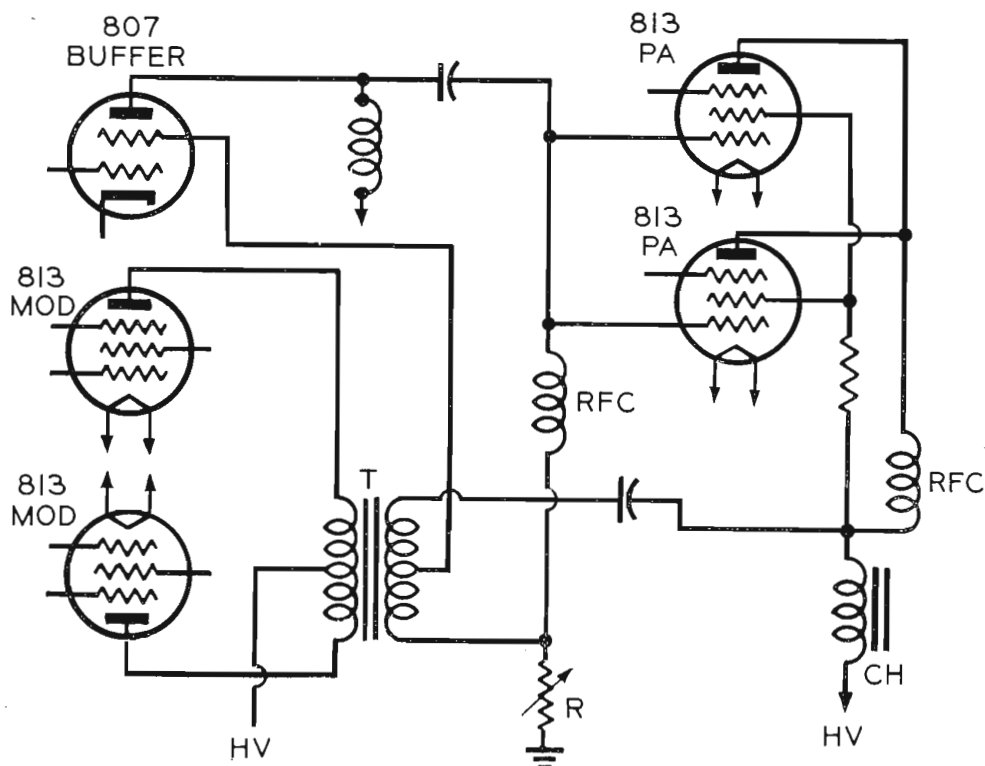

The BTA-250M employs four type 813 tubes, types which in service have proved their long life and dependability.

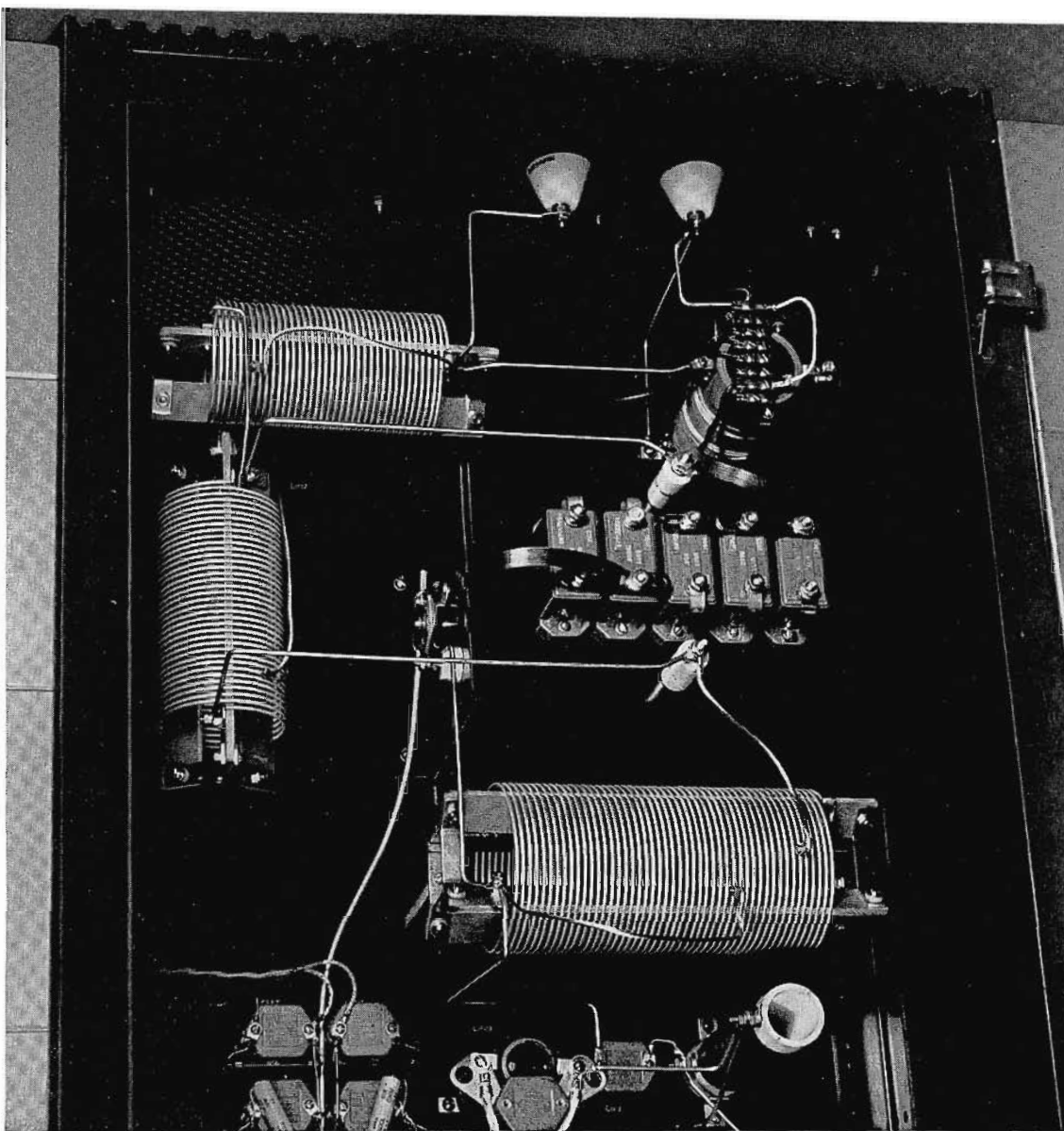

The BTA-250M features ease of accessibility to all components. In this rear view photo are the power amplifier tank circuit and antenna matching elements diagrammed below. The tank coil is the horizontally mounted inductance at the bottom of the photo. Coaxial type transmission line, when installed inside the transmitter, is brought through the base and connected directly to the output circuit at the top, eliminating the need for feed-thru insulators.

switches. These breakers are located in the filament, plate, PA and modulator cathode circuits. Application of plate voltage is controlled by a time delay relay, which is the only relay in the transmitter.

Dependable Low Cost Tubes

Beam power tubes are used throughout the new transmitter. In the r-f section, use of these tubes obviates the need for neutralization and thus removes the danger of poor modulation capability and spurious frequency emission, by-products of improper neutralizing adjustments.

Since most all air outages are caused by tubes, the few tubes and few tube types

Schematic diagram of the power amplifier tank circuit and output matching network. Symmetry in the network presents the same impedance to both sidebands, eliminating a source of distortion. The variable condenser shown in this diagram is the only tuning control in the transmitter.

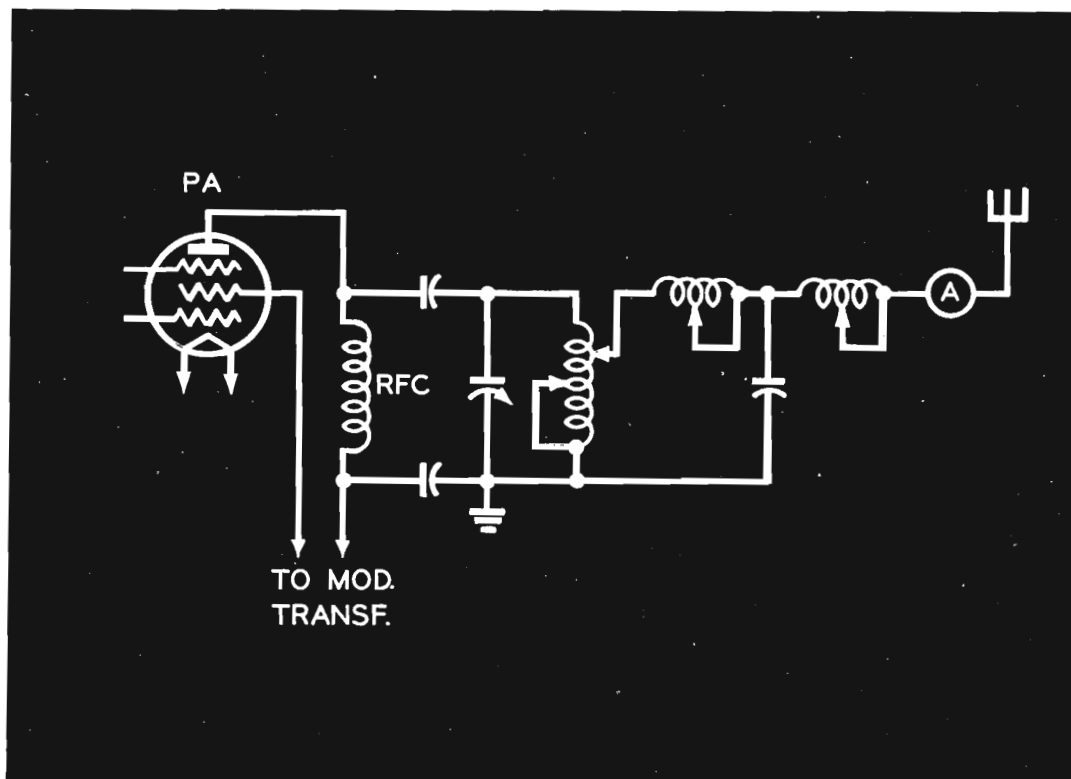

THE BTA-250M TRANSMITTER IS STANDARD

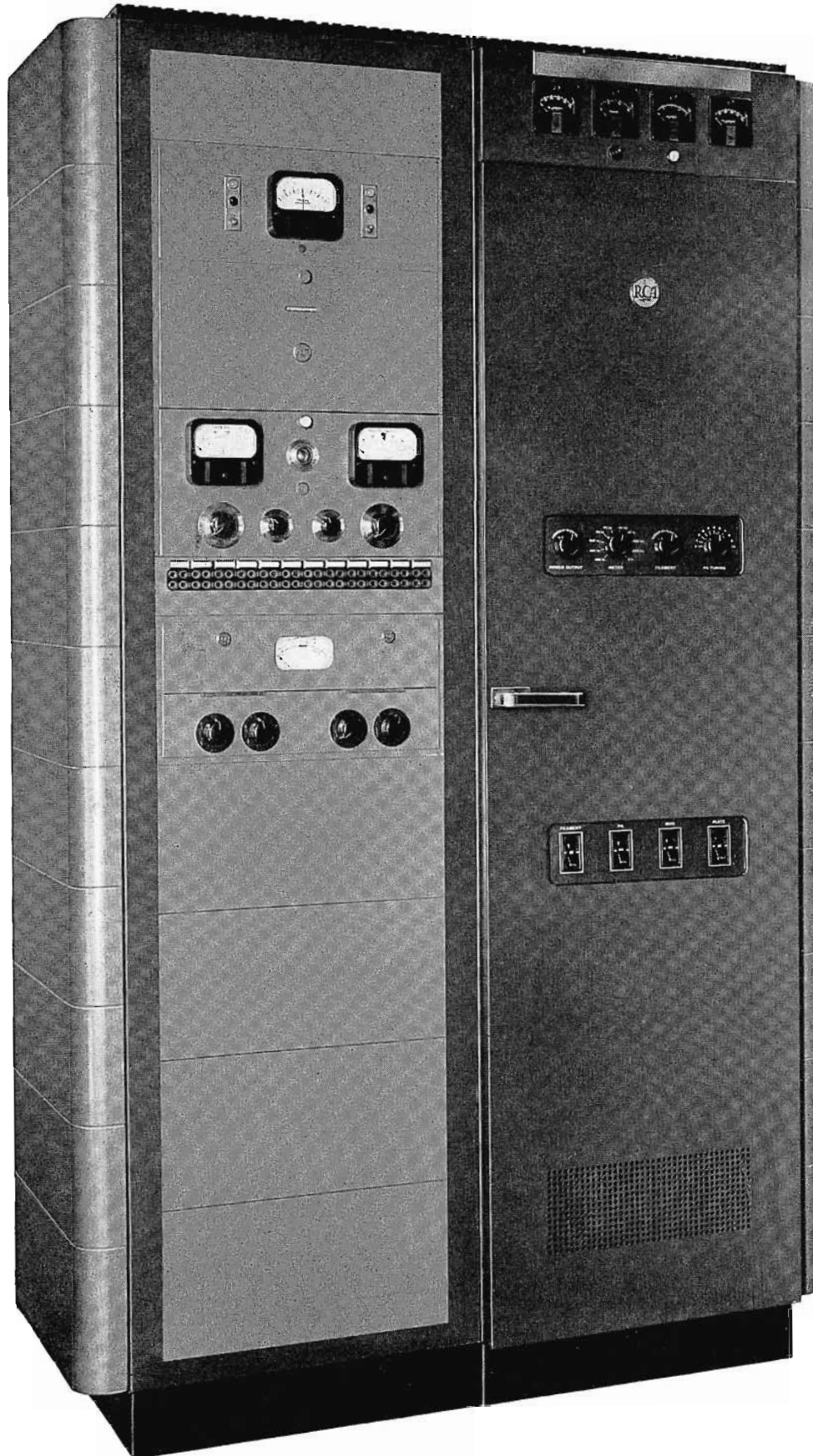

in the BTA-250M are contributing factors to the reliability of the new transmitter. Of the ten tubes in the entire transmitter, there are only three different types, four 807's, four 813's, and two 866's. These are types which are well-known for their long service and dependability, and are readily obtainable at most sources of supply. Metering is provided for all tubes in the transmitter by four meters mounted in the upper front panel. Three of these meters indicate plate voltage of the output stage, plate current of this stage, and r-f output current. The fourth meter which is connected to a ten-position switch on the front panel, is used to meter grid, cathode and plate current of the remaining tubes in the transmitter.

One Room Operation

One big feature of the BTA-250M is the great reduction in weight and size, brought about by advantageous cabinet construction and higher efficiency circuits. The overall width of the cabinet (including trim and sections) is only 28 inches. The depth is 20 inches, and the height 84 inches. This cabinet for the new transmitter was chosen to match the size and styling of broadcast audio and monitoring equipment racks. A cabinet rack containing audio and monitoring equipment placed beside the transmitter as shown at left, makes a compact unified looking package and contains all the transmitting equipment required for a 250-watt station. Since the transmitter does not use air blowers or a-c contactors to make noise, it can be placed directly in the room where announcements are made. These features make the equipment useful as emergency transmitting gear installed side-by-side with audio racks in the master control rooms of larger broadcast stations. Noise-free operation may save the expense of a partitioning wall or another room for the transmitting equipment.

View at left shows how effectively the BTA-250M can be installed beside a standard rack containing FCC required input and monitoring equipment. The rack-mounted equipment in this photo consists of the RCA BW-11A Frequency Monitor (top), BW-66E Modulation Monitor, and BA-6A Limiting Amplifier.

CABINET SIZE

Photo at right shows the transmitting equipment installed beside an audio rack containing the RCA Tape Recorder. Because the size and styling matches standard audio equipment, the BTA-250M is ideal for installation in master control as emergency transmitting equipment.

Accessory audio and monitoring equipment can be mounted recessed in the cabinet, if desired, so that doors can be added to these adjacent cabinets. Panel-mounted extension meters shown below are available for this type installation.

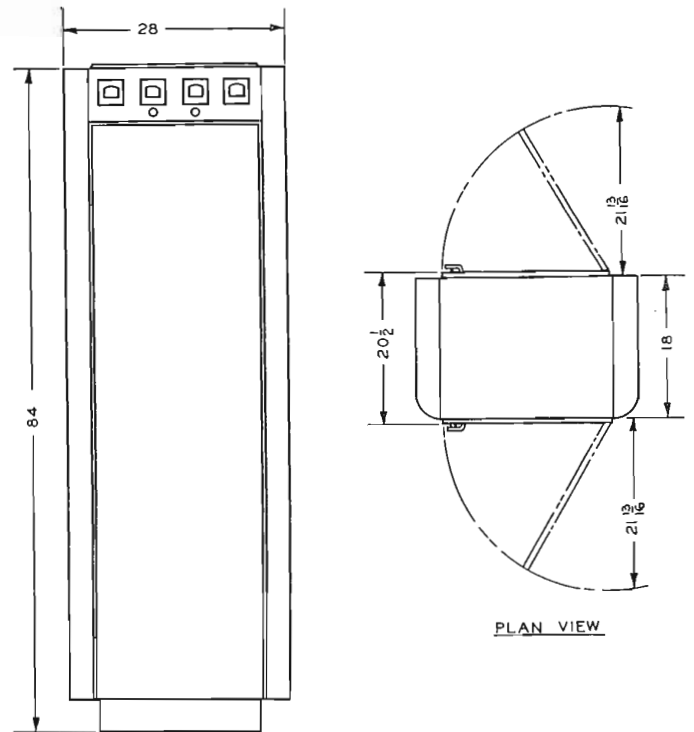
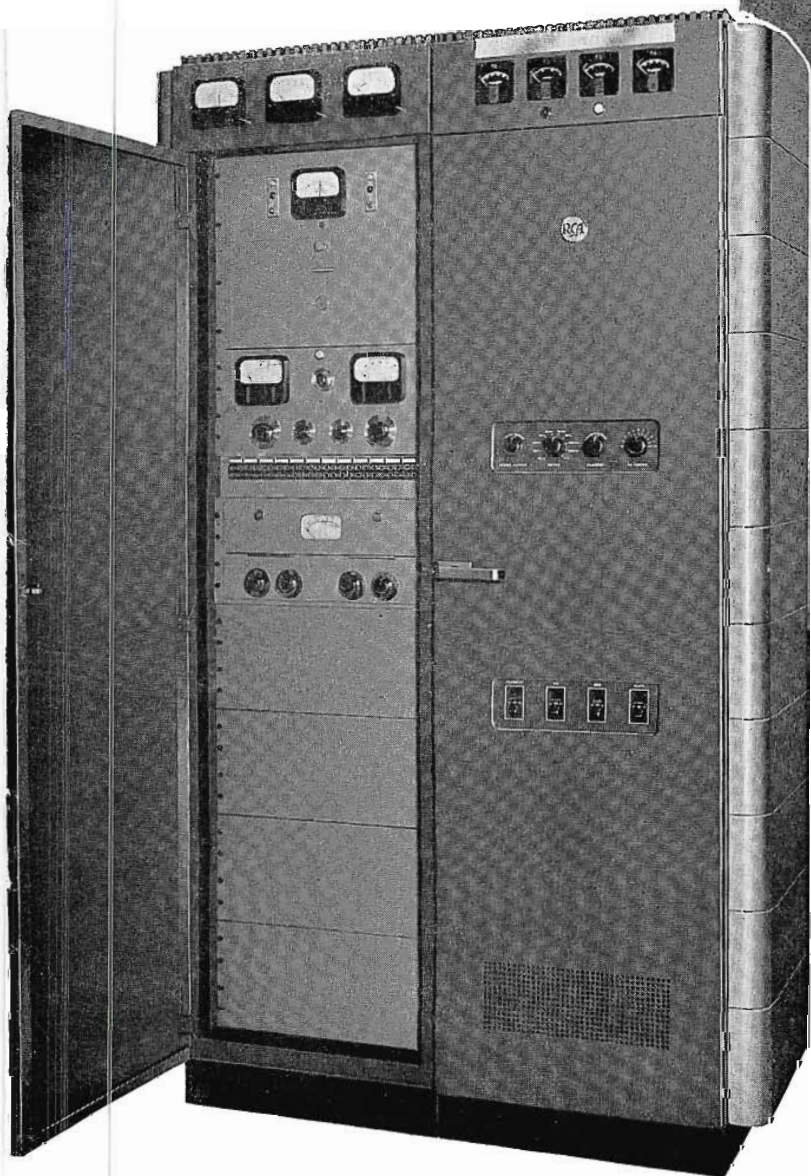
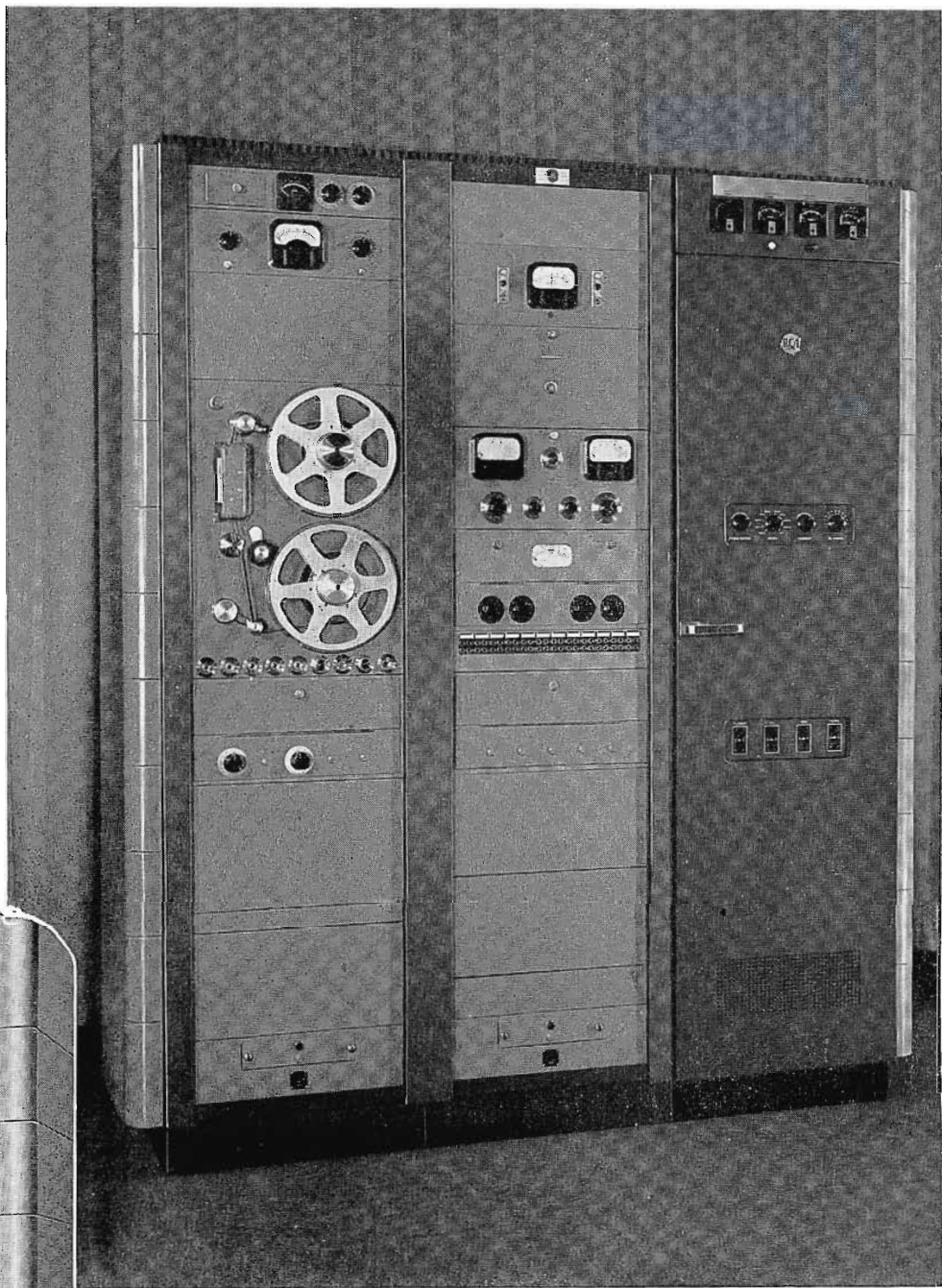

Outline dimensions of the BTA-250M.

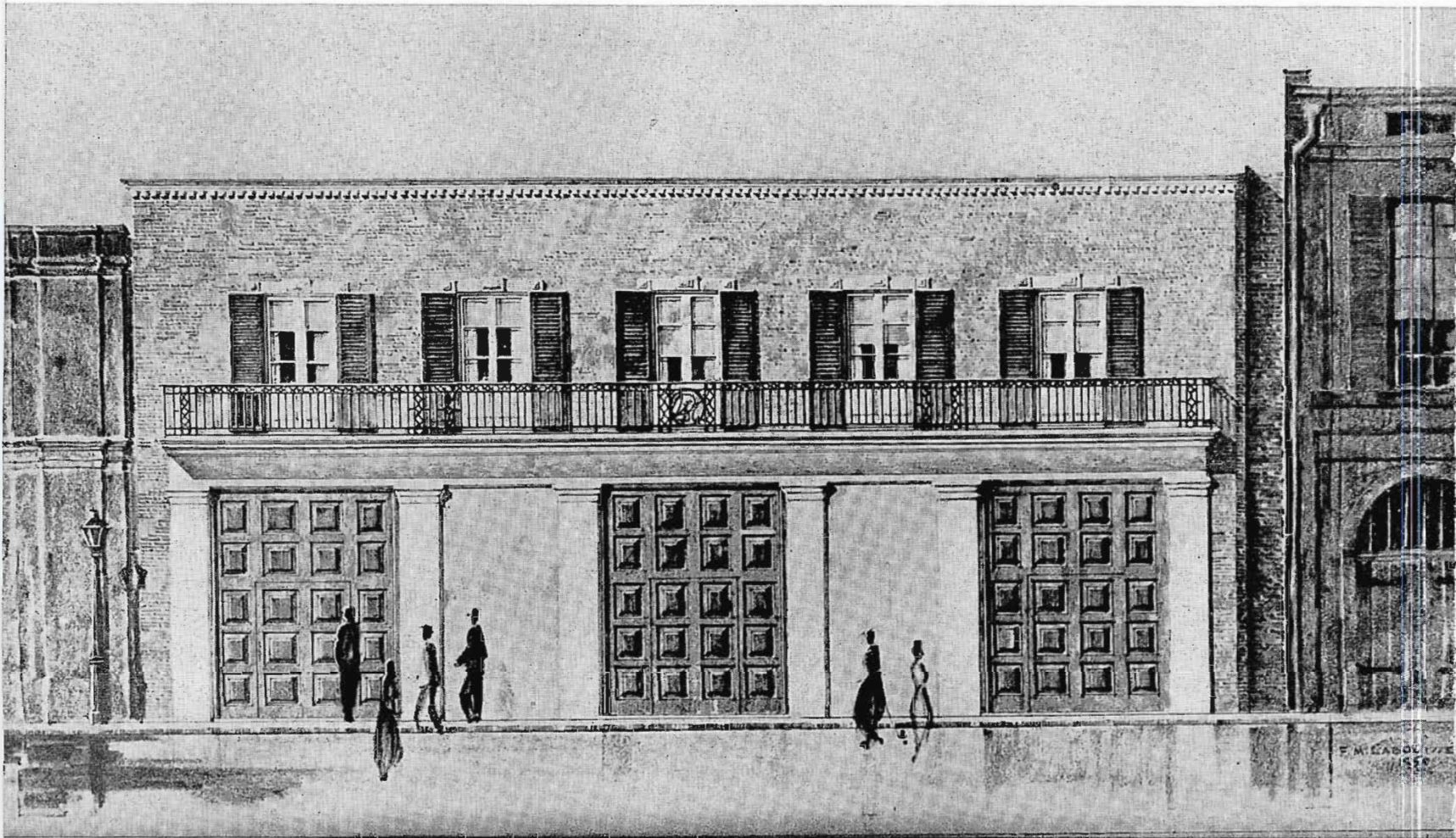

FIG. 1 (above). Artist's drawing showing the facade of the new WDSU/WDSU-TV studio building.



The best of the old and the new

by the
WDSU Engineering Staff

Located in the heart of the Vieux Carré, the famous French Quarter of New Orleans, the offices and studios of WDSU comprise a study in contrast—with the charm and beauty of old New Orleans combined with the most modern and latest broadcasting and television techniques.

When the Edgar B. Stern family purchased the station, its studios and offices were crowded in a local hotel. Today, under the guidance of Edgar B. Stern, Jr., Managing Partner, and Robert D. Swezey, General Manager, the home of WDSU is 520 Royal Street. The station's offices occupy the old Brulatour Mansion, one

of the oldest and most beautiful landmarks in New Orleans. The studios are housed in a new adjoining building and represent the last word in equipment and function.

Entering WDSU's offices and studios from the street, the center of attention and attraction is the Patio—the old Brulatour Courtyard. The Court with its surrounding shops and winding stairway leading to the old slave quarters, is perhaps the most

photographed patio in the country. Offices for station personnel still retain the flavor of old New Orleans. Very little was changed structurally in converting the Mansion into working offices. On the third floor the original music room with its complete organ, beautiful carvings and old wood floor stands intact and serves as the entrance to the executive offices. As a matter of fact the music room also serves as the setting for "Courtyard Echoes," a weekly WDSU musical program. The executive offices—formerly the drawing room—with its crystal chandeliers, huge fireplaces, handsomely carved desks also



▲
 FIG. 2. The original "Mansion" Music Room serves as entrance to the WDSU executive offices.

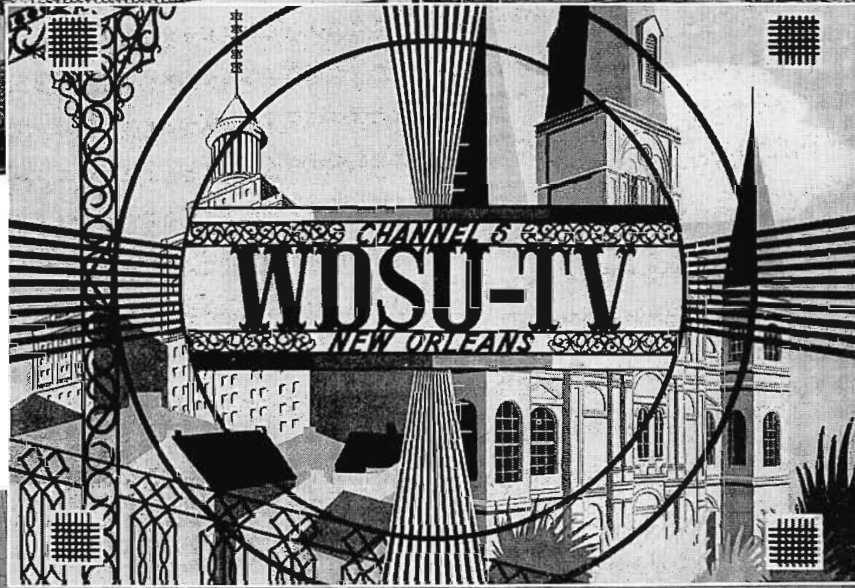

▼
 FIG. 3. The WDSU "audition" and client "viewing" room.



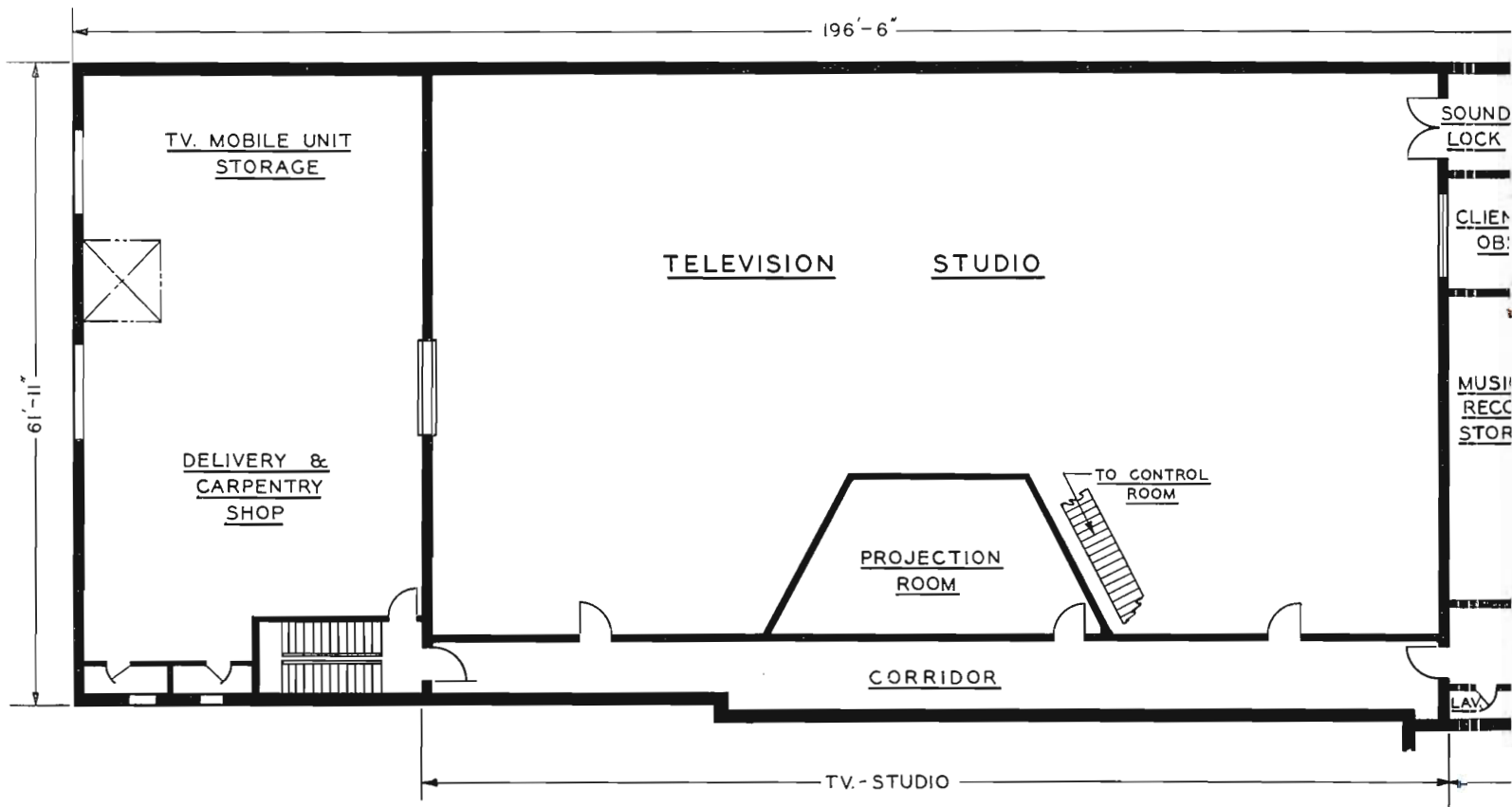

FIG. 4 (above). Layout diagram showing arrangement of WDSU-AM/FM and TV Studio facilities.

reflect the charm of the old mansion as does the audition room—the former master bedroom—with its massive fireplace and large picture windows.

Studio Building and AM Studios

Now, directly to the rear and adjoining the old Brulatour Mansion are the new radio and television studios of WDSU. These occupy a brand new building designed to provide efficiency and economy in the combined operation of an AM and TV station. The entrance to our studio building marks an abrupt transition from the old traditional New Orleans atmosphere to the new modern requirements of broadcasting and telecasting. This new building was constructed with the belief that AM and TV studios should be adjacent so that the facilities of each could serve the other—not only to allow personnel to move from one to the other quickly and with ease, but also to permit a certain amount of equipment to be common to both. For instance, remote control lines for both services are brought into a central panel in the AM Master Control Room, thus providing a substantial saving.

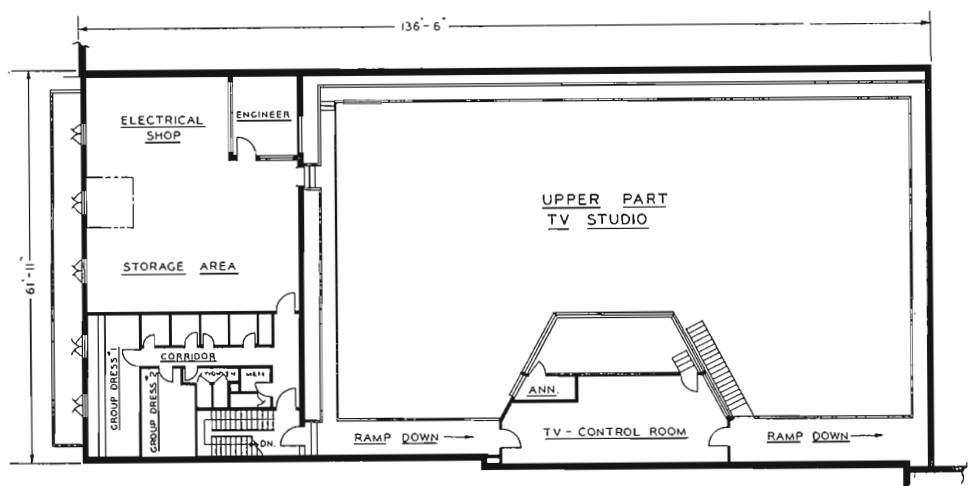

FIG. 5 (above). Floor plan layout showing the upper part of the TV studio.

The design of the AM Studios permits the ultimate in flexibility and allows operation by a minimum of personnel. The main feature of this design is the location of the Master Control Room, which has been constructed as an island in the middle of three AM Studios of

varying sizes, Studio A is thirteen feet long and eighteen feet wide and was designed to handle our disc jockey shows and small interview programs. It is equipped with two turntables with facilities allowing the announcer control of his own microphone if he desires. Facilities for making cut-in announcements

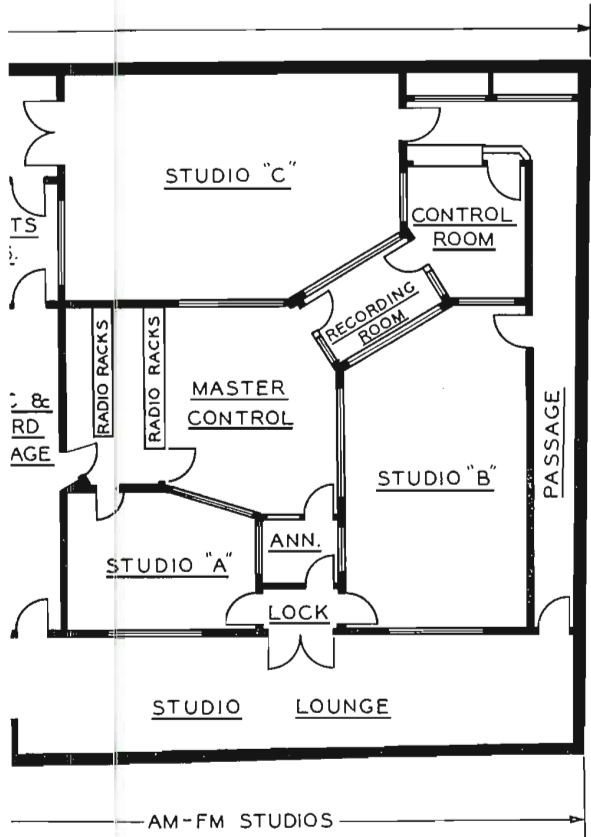
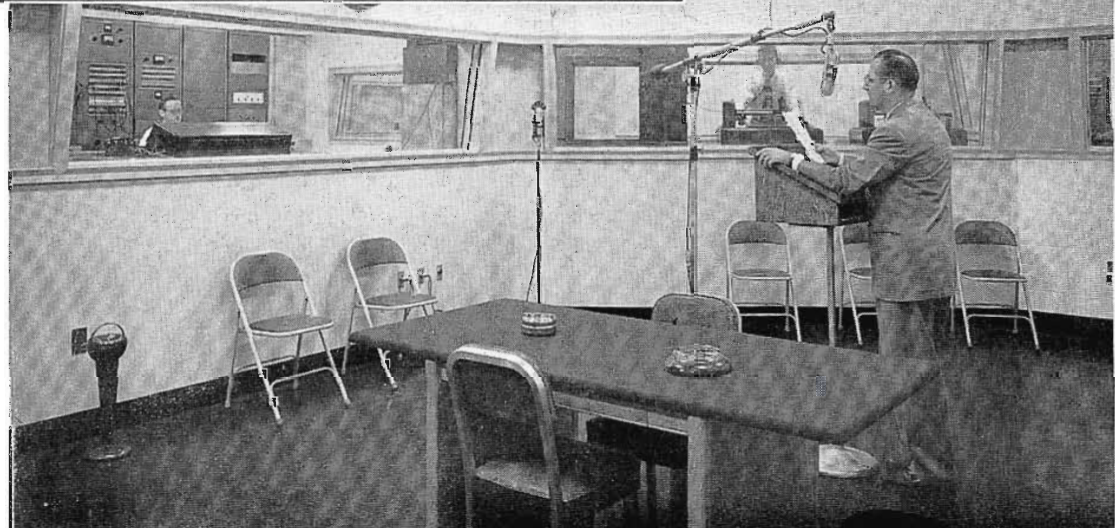

FIG. 7. WDSU Studio "A" which is used for news announcements and disc jockey programs.



FIG. 8. View of WDSU Studio "B" with the Control Room visible at the left and 73-B recording facilities on the right.

FIG. 6. View from WDSU Studio "C" looking into the studio control room.



in network and other programs are provided, the program being fed to headphones or speakers to permit accurate cueing.

Studio B, which is seventeen feet and four inches long and thirty feet eight inches wide, is for our larger shows and can accommodate a studio orchestra or large group.

Studio C, the largest of our AM Studios, is twenty feet nine inches long and thirty-one feet six inches wide and in addition to performing the functions of Studio B can accommodate an audience of up to 100 persons. This studio can also be used for television programs, since at one end its large double doors open directly into the television studio.

A second control room, situated between Studios B and C, handles rehearsals, network feeds and recording sessions without interfering with the routine operation of the station.

The recording room equipped with the most modern tape and dual RCA 73-B disc recorders is located between the two control rooms, and can be operated from either one. Large windows on each side of this recording room permit accurate cueing.

The compact arrangement of the auxiliary control room, recording room, and Studios B and C gives WDSU one of the most modern and best recording studios and facilities in the city. The entire setup

provides a good balance between the small station type of single central master control and the large station separate control room operation.

On the perimeter of the studio group is a large lounge, from which station visitors and the public can view our AM operation. Previous experience has shown that it is important to have such a room for guests of speakers and performers, and for the public who like to be permitted to see radio broadcasts in action. The long, narrow room adjacent to the lounge and accessible to all studios is used as Record Library and News Room. Behind it, a room originally intended as a client's booth for Studio C and for the Television Studio,

FIG. 9 (below). The WDSU Recording Room facilities include the two RCA 73-B Professional Recorders shown here.

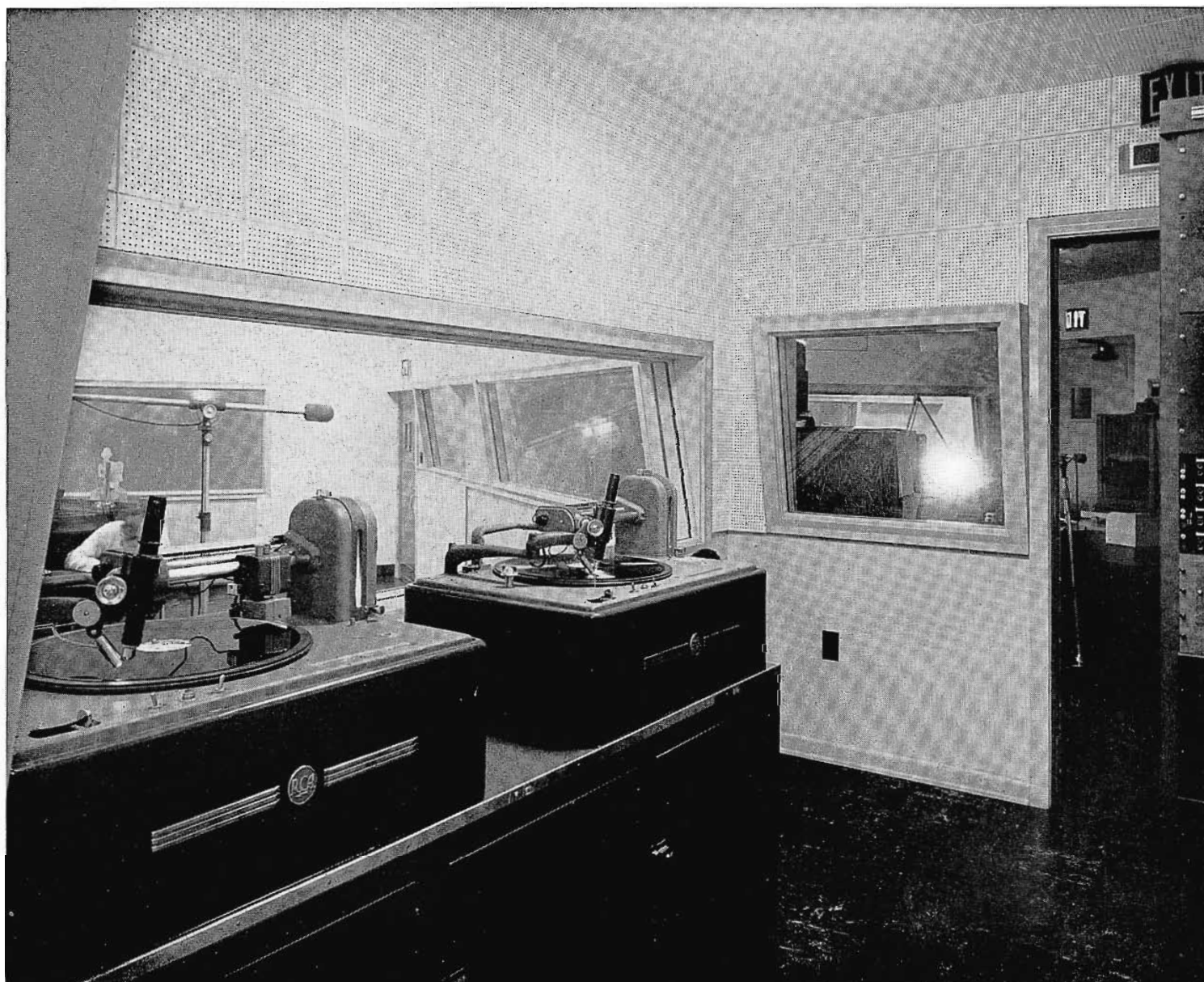



FIG. 10 (above). The WDSU-TV studio was built with an eye to providing plenty of space (100 feet by 55 feet). "Drive-in" facilities are provided.

has suffered the fate of any extra room in a television operation—it has been taken over for storage of television film.

Television Studios

Directly adjacent to our AM studios is the television studio. Benefiting from the experience of television stations all over the country, we decided to go far beyond our immediate requirements in designing our studio. We decided the only limitation on its size should be the lot on which it was built and the space required for AM and other facilities. The television studio itself is one hundred feet long and fifty-five feet wide. In planning the control room for the television studio we debated for

many hours whether to locate it at one end of the studio or in the middle of one of the long walls. We decided on the latter, because we felt that eventually we would want to divide the studio into two parts. This decision has been wise, we think, because we are already realizing the need for such a division.

We placed the control room high enough in the air so that sets directly in front of it do not obstruct the operator's view. This arrangement allows every inch of wall space in the studio to be used for placing of scenery and props.

The control room itself is a departure from the standard setup of earlier television. In most cases the engineers' monitors

are situated in front of the director's console and at a lower level, with the director looking over the heads of the engineers at the picture monitors. Experience proved to us that this plan had limitations in event of a technical failure, since engineers would be scurrying around to repair the difficulty or replace the defective component. This inevitably would be distracting to the directors. Therefore, we revised the usual control room arrangement and placed all engineer monitors and control room equipment in the rear of the control room and at a higher level. Thus, the engineers are in a separate room, next to the equipment racks, but still command a clear view of the studio and the production desk.

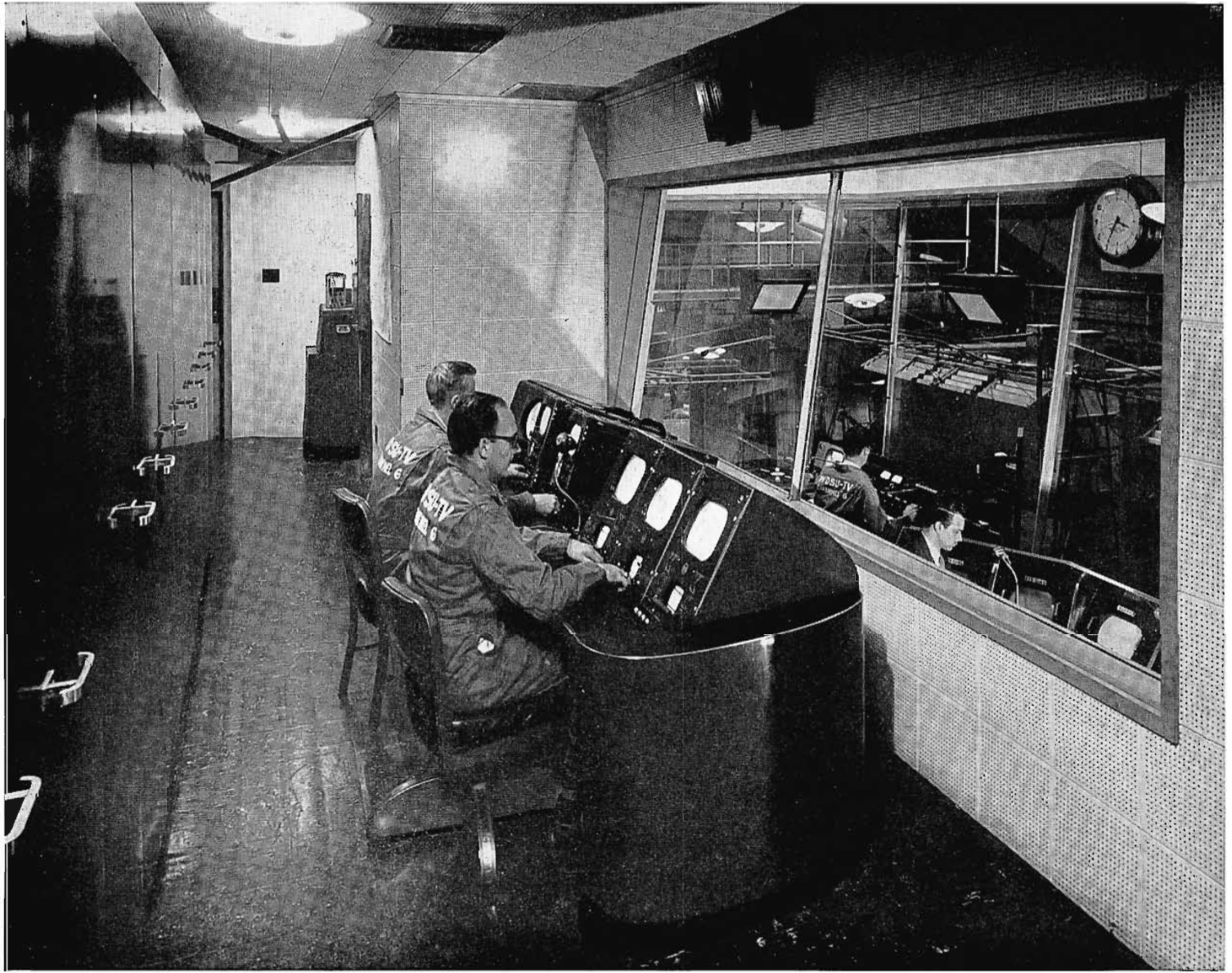

FIG. 11. Close-up view of the WDSU-TV Control Room facilities which are located on a higher level than the studio to make both the studio and production desk easily visible.

The directors and producers operate from our specially constructed console which is located in the front portion of the control room. The production desk is equipped with monitors which show the pictures on every camera—studio or film—in the station. The console controls all video switchers and the inter-communication system. In addition, the console affords directors a better view of the studio floor.

The console has seven monitors in all: three for studio cameras; two for film cameras; one for an “off-the-air” picture; and another which serves as a preview monitor. The picture on any monitor can be changed

by means of patch cords thus giving complete flexibility to the board. Duplicate RCA TS-10A switchers allow one show to be on the air while another is being rehearsed. A master RCA TS-1A switcher selects which channel will go on the air. One of its buttons operates a relay at the transmitter for switching from studio to remotes. Remote telecasts are microwaved directly to the transmitter.

Studio Sets

The main studio floor used for actual telecasting can accommodate as many as eight stages or sets. Thus, we can arrange all the sets for a day’s operation before we go on the air, and thereby eliminate much

of the bustle and confusion encountered in moving sets and props during actual telecasting. The sets themselves are made of four-foot panels so constructed that they can be bolted together in various arrangements. By building some panels with doors and some with windows, we can construct an entire living room set within a few minutes.

At one corner of the studio, a permanent kitchen, complete with provisions for hot and cold water, drains, gas and electricity, has been installed. On another set we have constructed a special swimming pool. This pool has a special plexiglass window which allows us to telecast underwater pictures.

The pool is used for demonstrations of water safety as well as for commercial shots.

Other Facilities

The rear section of our television building is the only two-story portion of our studio. The ground floor of this section is used for garage and storage space. Two large doors separate the telecasting studio from this storage-garage space. These doors are large enough to allow passage into the studio of fire engines, automobiles, boats, horses and other large size objects.

Dressing rooms, carpentry shop and an electronic repair shop occupy the upper floor of this section. Our dressing rooms consist of four individual rooms, two group dressing rooms and men's and women's baths. Part of the carpentry shop houses

the bulky air conditioning equipment. But Telecasters beware! This is where we—and many others—have fallen short in our planning. It is already very apparent that we do not have enough storage space. Originally, both floors of this section of our building were to be used for storage space, but as it inevitably happens, you find you must have dressing rooms, carpentry shop, parking space for the mobile unit, a place for air conditioning and heating equipment, a repair shop—and where to put it—the storage space, which at the time doesn't seem to be as important. This is a grave error! Every station should have as minimum storage space, an area equal to the floor space of the studio to take care of the station-owned properties that accumulate and to accommodate properties belonging to clients which you also must

store. A catwalk fourteen feet above the floor has been constructed completely around the studio. This was originally intended mainly for mounting of spotlights and overhead shots, but already has seen use as a point for dropping garbage cans for sound effects and also as a spot from which men jump into fireman's nets for safety demonstrations.

Studio-Video Wiring

Our one thought in designing the studio-video layout was to provide a flexible yet simple system. For this reason we decided upon a two-channel system (with provision for a third, when and if it becomes necessary) that allows each channel to operate independently. The output of each camera is fed into two switchers which, in turn, is fed into the master switcher. This master switcher has three outputs: one, a

FIG. 12 (below). Simplified functional circuit diagram of the WDSU-TV Video facilities.

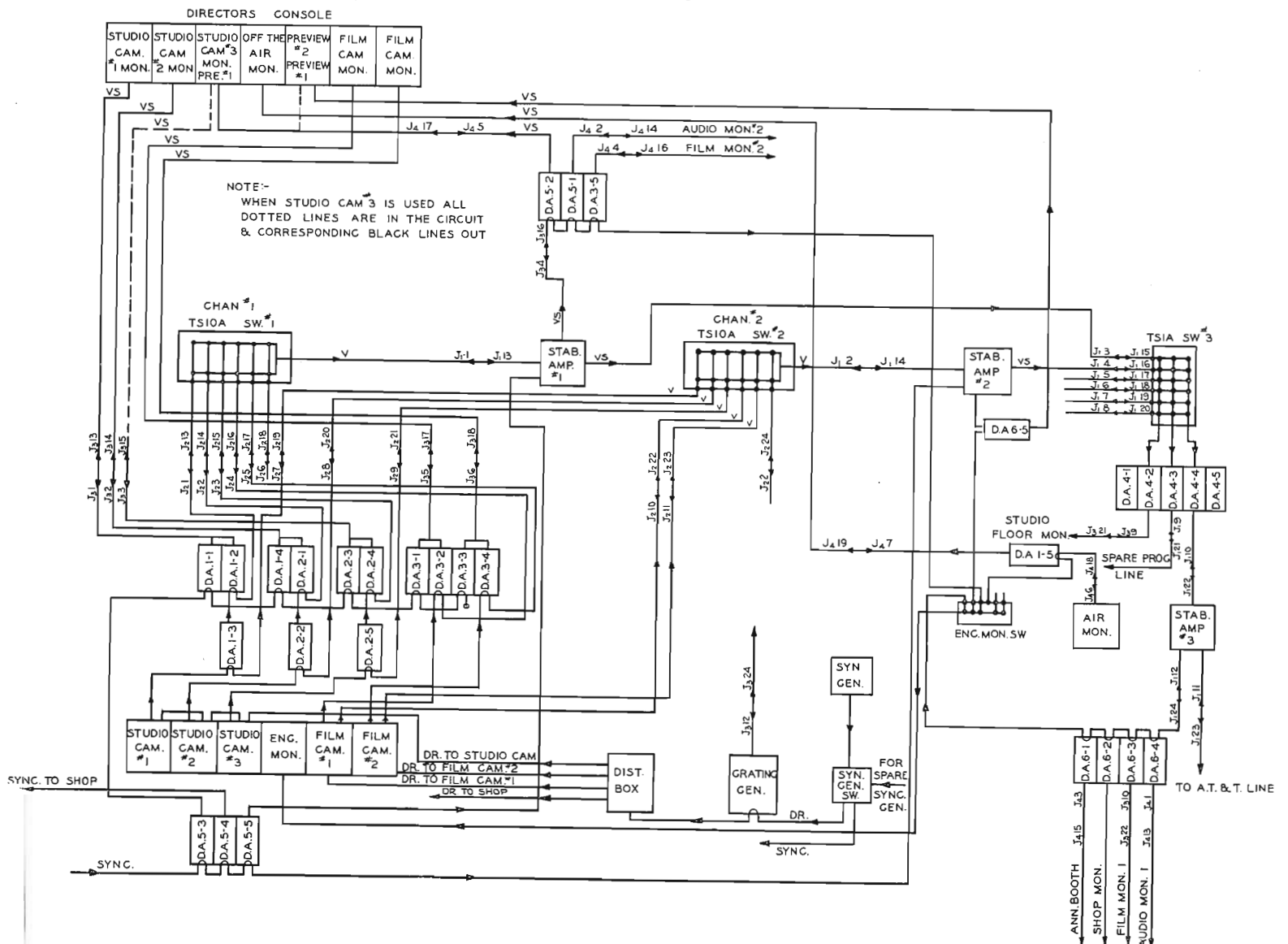

program line; the second, a spare program line and the third, a monitor line. The latter is used to feed a studio floor monitor on which either a rehearsal or an on-the-air program can be seen by merely pressing a button. All video lines have been brought up to a jack panel where, if necessary, patching of any kind can be done, thus adding to the flexibility of our operation. We have a duplication of almost all of our video equipment except for the sync generator. However, our field sync generator is used as a stand-by and can be put into operation by merely flipping a switch. In addition, the remote microwave transmitter can be used as a studio-transmission link in case of telephone company equipment failure. A preview monitor with its selector switch allows us to check the picture and wave form of both channels, the program going to the transmitter, and the off-the-air signal. A push button on the preview monitor is fed by an RCA T-100 Receiver. This has been accomplished by adding a stage to the receiver and feeding its output to a distribution amplifier. Thus, with a minimum loss of time and effort we can compare signals and trace down technical difficulties at their origination.

Audio Control Board

In our control room is the audio control board which is located at the front, next to the director's console. Here again our engineering staff has done a little redesigning to provide us with additional facilities. A standard audio console has been remodeled to allow us to feed film, sound, tape machines, remotes, two transcription machines and as many as seven microphones on either one of the two audio channels. We have also added extra monitor amplifiers to feed Channel 1 or 2 to the control room, to the studios and to the offices in the Brulatour building. In addition, we have made it possible for the announcer in the announce booth to operate his own microphone.

Intercommunication System

Another important and unique aspect to our TV operation is the intercommunication system as devised by our staff. Here, briefly, is how we have worked it out:

The intercommunication channels are labeled A and B in the block diagram and are identical in most respects. The director's microphone is followed by a pre-amplifier whose output drives a twenty-five watt standard public address amplifier which is then connected to the RCA TS-10A private line IC system by means

of an isolation cell provided by the manufacturer in the equipment. A key switch at the director's position permits selection or mixing of Channel A or B into the TS-10A. The private line stations of the TS-10A engineering and production circuits are paralleled into two separate groups, thus providing an exclusive circuit for the use of the technicians, allowing them to work on the cameras at the same time that the other IC channels are in use by the production personnel. We have dispensed with the usual director's headset by using an amplifier which ampli-

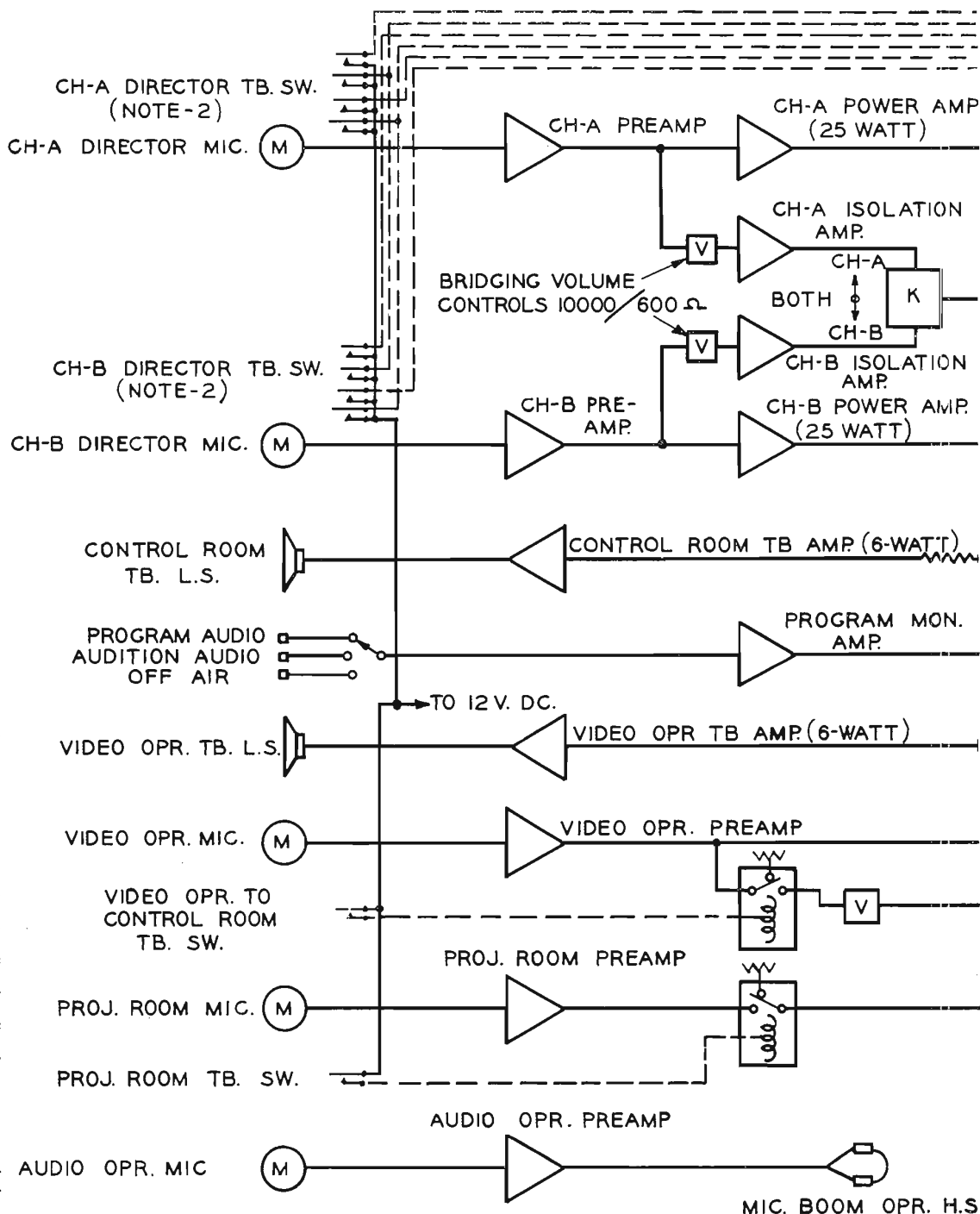

FIG. 13 (at right). Interconnection diagram illustrating the intercommunication channels employed by WDSU-TV.

fies the incoming signal from the TS-10A and feeds a control room talkback loud-speaker. Feedback is eliminated by the use of a balanced bridge circuit and a noise cancelling differential microphone.

Provision is also made for the Projection Room and Video Operator, located in separate compartments, to talk to the control room through this speaker. Each director's position is equipped with a bank of key switches permitting him to address the following points: sound stage, announce booth, projection room, video operator, audio operator, and dressing rooms. The

output of the program monitor amplifier is fed to the speakers when it is not in use for intercommunication purposes.

It is almost a common incident to see this intercommunication system utilized to its maximum in a day's operation—live rehearsal with the studio while we are on the air with film, technicians adjusting cameras and other equipment, personnel being paged to answer phone calls, talent being alerted and called on stage from the dressing rooms, etc. After six months of operation from our new studios we are already

contemplating many modifications and extensions to this system to give us even smoother operation.

Returning to the physical appearance of our control room, directly to the rear of the audio desk is a small announcer's booth from which station identification and other "off screen" announcements are made. Both the audio control man and the announcer have on-the-air monitors, thus providing smooth operation and coordination.

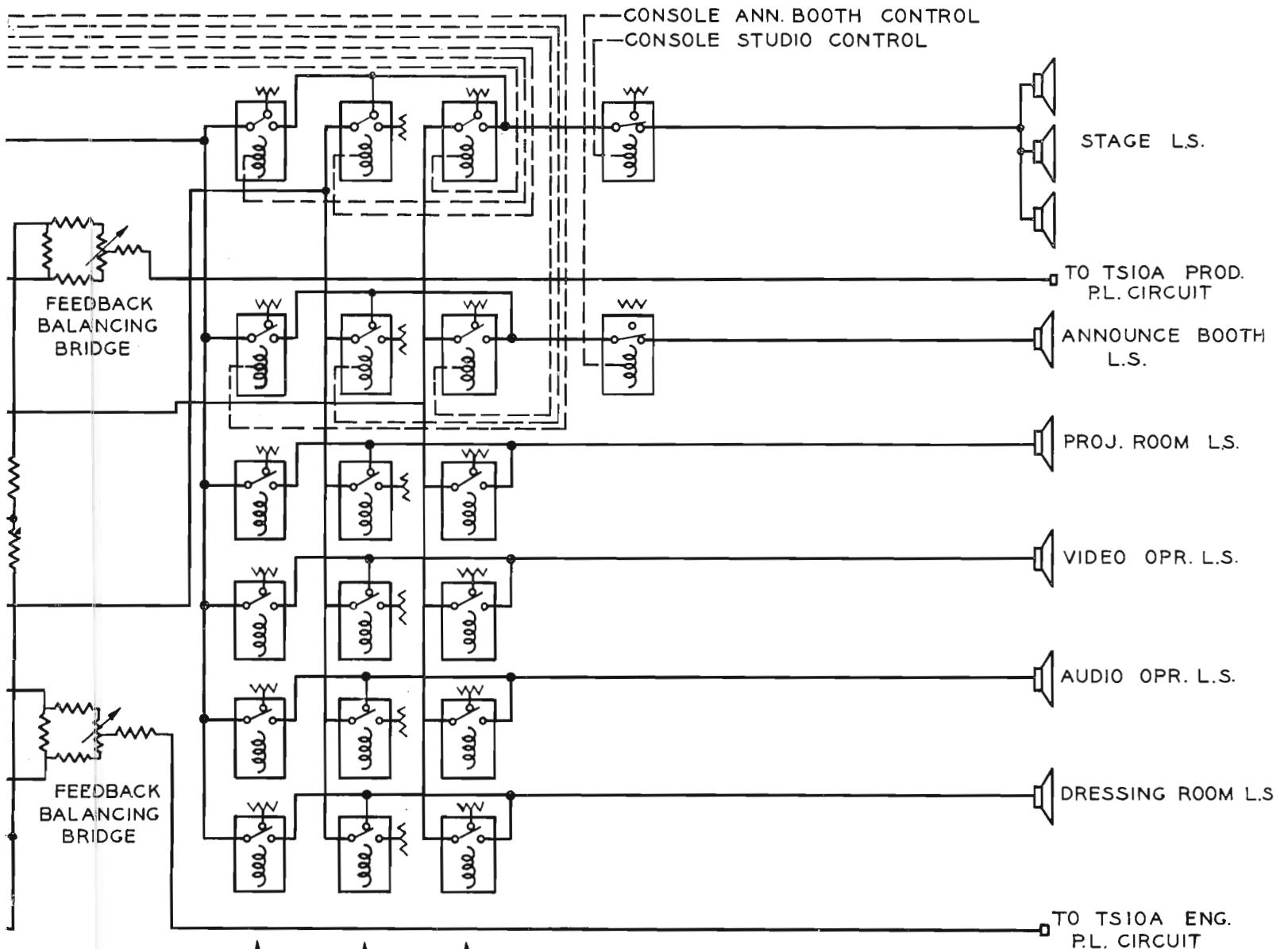

NOTES:-

1. CONTROL WIRING ARE INDICATED TO TWO GROUPS OF RELAYS ONLY. OTHERS ARE IDENTICAL.
2. TWO SWITCHES IN EACH DIRECTORS SWITCH BANK ARE SHOWN FOUR OTHERS NOT SHOWN ARE IDENTICAL.

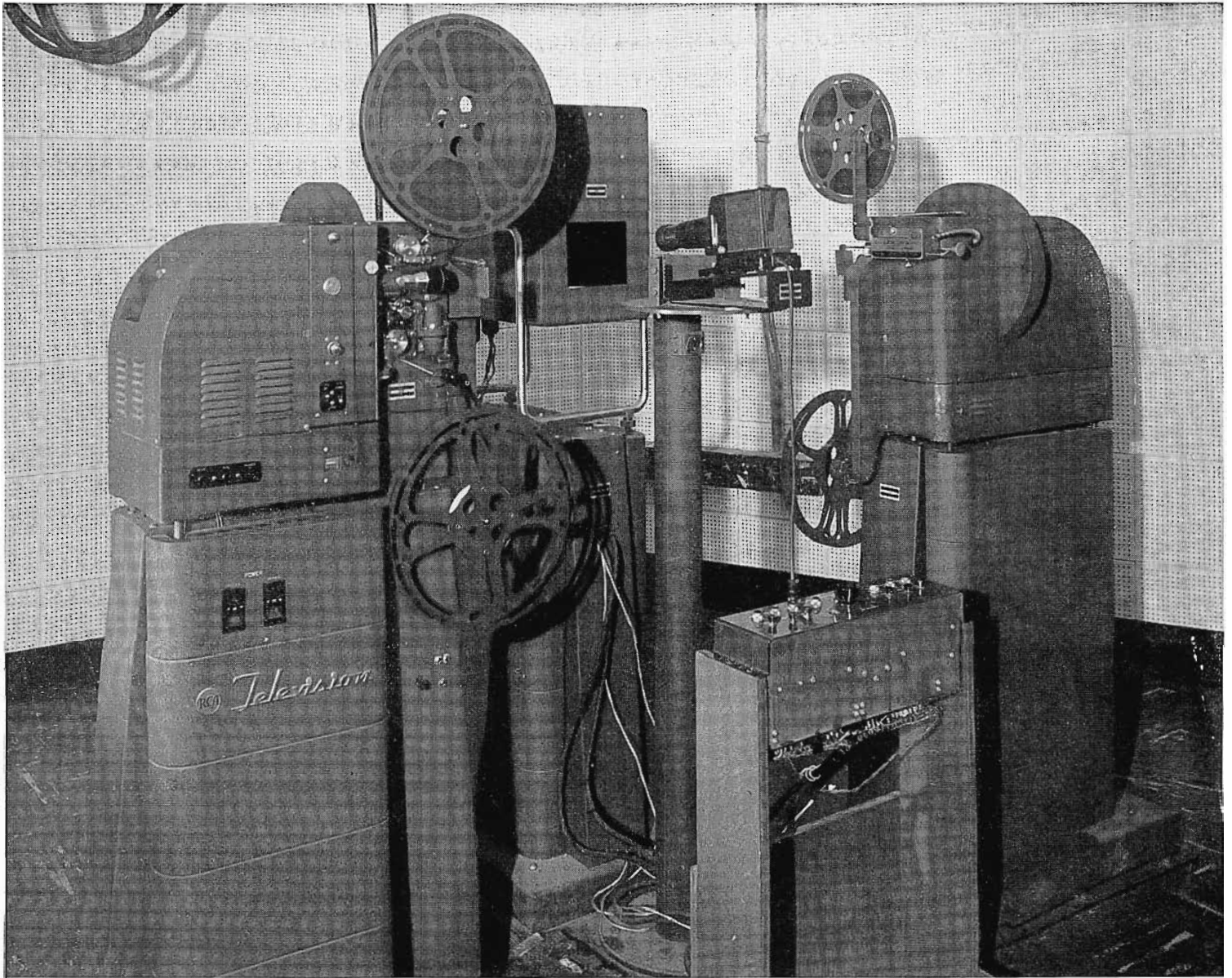

FIG 14 (above). Close-up view of the WDSU-TV Projection Room facilities showing the RCA TK-20A film camera and the TP-16A film projectors.

Projection Room

The projection room is situated beneath the control room. It is equipped with two RCA film cameras, one for motion picture projection, the other for slides. Our unique arrangement of slide projectors provides flexibility in handling slides of all sizes, opaques, creepers, etc. The combination of a dual Balopticon-slide projector has been a very useful programming tool, but in itself it has not been sufficient to handle all of our needs. Therefore, we have added a sliding mirror which permits an on-the-air wipe from this instrument to a 2x2 inch slide projector or to a 3½x4 slide projector. These last two instruments are projected onto a half-mirror; one shooting through it, the other's beam being reflected by it.

Thus, we are able to make an on-the-air switch, fade or wipe from one projector to another. Targets are available so that we can align and check slides before they are shot into the camera.

Remote Facilities

WDSU-TV has a large Lynn truck, converted for television purposes. It is equipped with two RCA field camera chains and the necessary switching facilities. The director and audio man have a small raised control desk in which the switching equipment has been mounted. They look over the heads of the engineers at the field camera monitor. A line output monitor, an off-the-air monitor and a relay transmitter control unit are located on a

shelf above the camera control units. Also, we have storage space for cameras, tripods, cable, etc. It has been our experience that a second truck is usually required to carry rope, extra camera cable and is often used for the mounted relay transmitter. The roof of our mobile unit is reinforced so that cameras can operate from the top of the truck. The wide rear doors of the unit allow easy moving of equipment and a special cable reel rack swings out in front of the opening for winding and unwinding camera cable.

Transmitter

WDSU-TV's transmitter is an RCA TT-5A located in the Hibernia Bank Building a quarter of a mile from the studio.

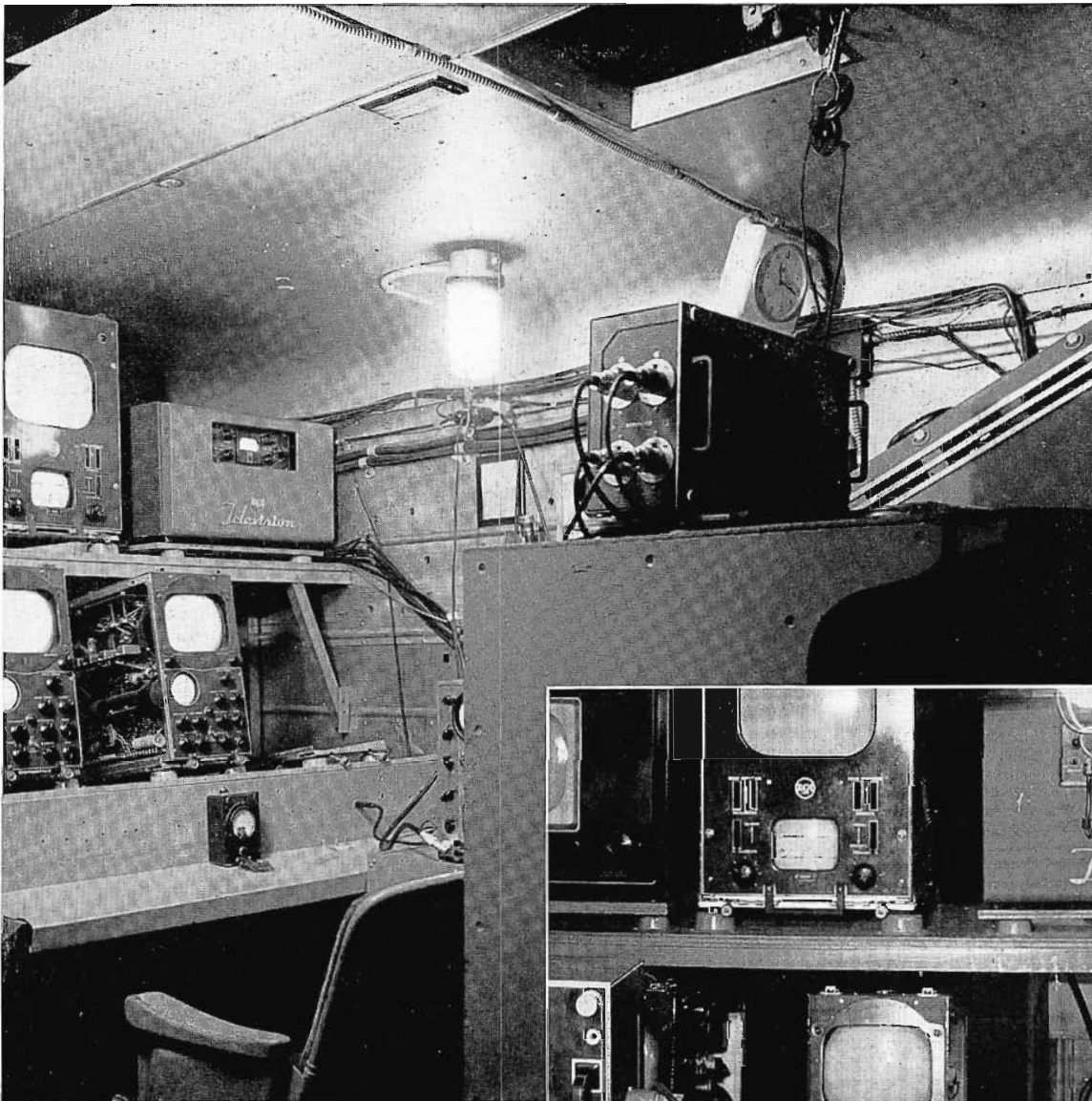

FIG. 15. View of the WDSU-TV Mobile Truck showing the "engineer-operator" position.

This bank building is the Empire State of New Orleans. The tallest building in the city, it has an observation platform on its dome which is 355 feet above the ground and affords a clear and excellent view of all sections of the city. This makes it the ideal location for the microwave receiving dish and receiver. 425 feet of cable connects the receiver to the receiver control in the transmitter which is located in a specially constructed room on the roof of the fourteenth floor of the building. The output of the receiver or the studio line can be switched into the transmitter by means of the relay that is controlled by the director at the studio console. In case of relay failure it is possible for the trans-

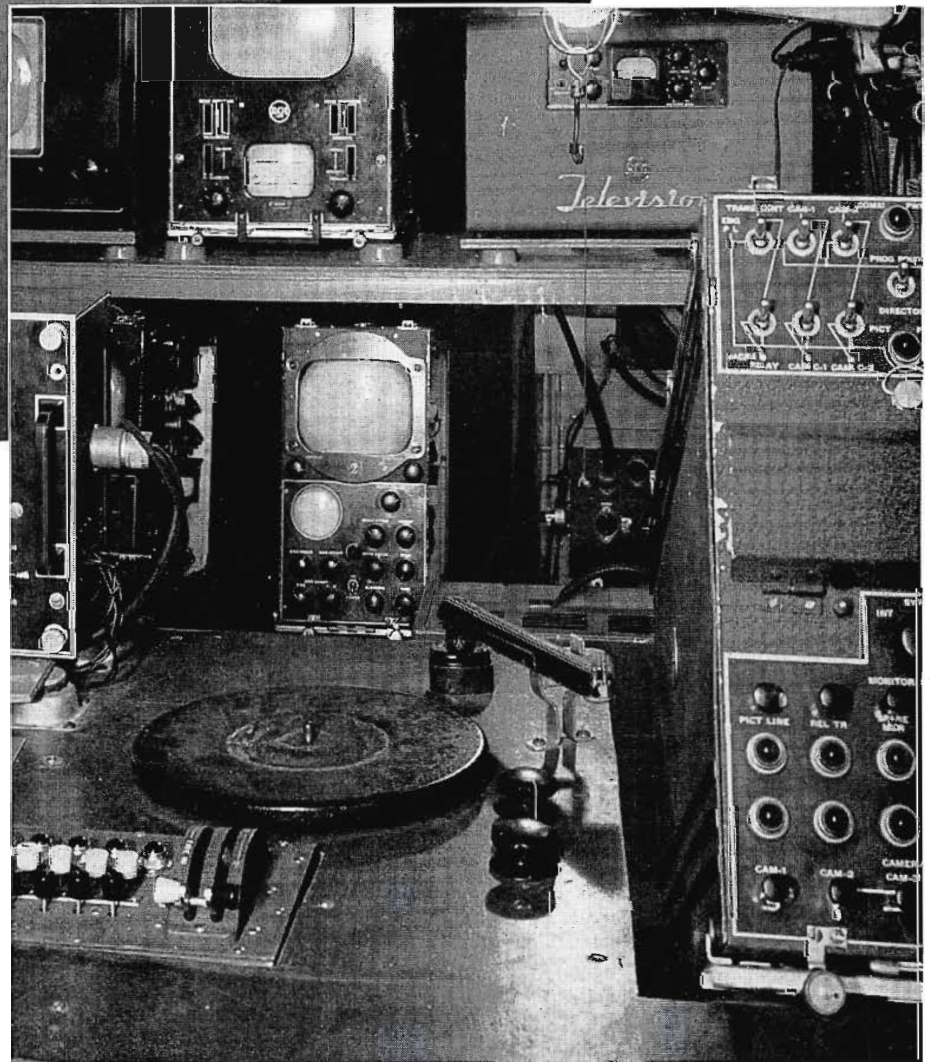

FIG. 16. Close-up view of a portion of the TV Mobile Unit showing the "Director-Audio Control" equipment,



mitter engineer to manually control this relay.

The selector switch and preview monitor allow us to check the picture at any point—from telephone line to output of the transmitter.

The five section antenna is mounted on the dome of the Hibernia Bank Building and is fed from the transmitter through 290 feet of transmission line. A triplexer is used to feed our WDSU-FM 3 KW transmitter into the same antenna.

AM Studio Construction

Here are a few construction details of the one-story AM portion of our studio building:

Partitions of the studios are of gypsum blocks coated with one inch of plaster on both sides. However, on all studio walls there is one inch of dead air space between the plaster and the gypsum tile. The studio ceilings are made up on one inch of plaster suspended on wire laths and covered on top with six inches of fiberglass bats. Double glass windows of $\frac{1}{4}$ - and $\frac{3}{8}$ -inch thicknesses are used throughout. To provide adequate sound isolation it was necessary to pump caulking compound around all the window and door frames. Although the studios are not full-floating, this type of construction gives a forty-five decibel drop from one room to the other. Since control rooms and other passageways separate the studios, the isolation from studio to studio is more than adequate.

Fiberglass placed on top of the ceiling helps to deaden the attic and prevents the passing of sound from one ceiling to another.

Special precautions have been taken with the grounding of all pipes, conduits, etc. There are no closed ground loops and each ground leads into the central ground system. All audio wiring is grounded only at one point.

The frame of the AM studio building does not touch the frame of the television

FIG. 17 (at left). The WDSU-TV Super Turnstile Antenna is situated atop the Hibernia Bank Building, the tallest structure in New Orleans.



FIG. 18 (above). Front view of the neat, flush-mounted arrangement of the WDSU-TV, RCA TT-5A Transmitter.

studio building except at one point, a four-inch copper ribbon. The ground system for the AM studios as well as the TV plant is made up of eight-foot copper rods driven into the ground, directly below the equipment racks, and connected by copper ribbon. All grounding is made of this one ground point. Incandescent lighting has been used in preference to fluorescent, to eliminate any form of "hash" or "clicks."

Construction Details of Television Studio Building

Here are the construction details of the television studio: The walls are of concrete blocks covered on the inside with one layer

of fiberglass held up by chicken wire. The roof is supported by steel trestles and has a fiberglass coating on the under side, which seems to be adequate as no objectional roof noises, as yet, have been encountered. The studio floor is a single concrete slab with a hardened surface.

Electrical power for our operation is furnished through 3 phase, 4 wire, 220/110 volt power outlets located every 20 feet along the studio walls. In addition, we installed power outlets in the center of the studio floor—but to date, we have not used these floor outlets to any great extent. Portable distribution boxes are used to control the lights on any particular set and

can be plugged into the nearest power outlet.

Air conditioning is provided with ducts which run along the roof line and drop down over each set. These ducts may be pulled up out of the way whenever necessary. Each duct has its own damper, so that the degree of cool or hot air on each set can be controlled. Cold water for the air conditioning system is purchased from an adjoining ice house, thereby eliminating the expense and noise of compressor units.

The exterior of our studio building conforms architecturally with the old French Quarter buildings and again combines the best of the old and the new in New Orleans.

A VERSATILE VIDEO SPECIAL EFFECTS SYSTEM

Introduction

Special effects, both optical and electrical, play important parts in modern television productions. It is frequently desirable to combine two or more scenes into a single picture or to remove a portion of one scene to replace it by a portion of another scene. Such effects can be especially satisfying to the sponsor of a program because it is possible to display a commercial on a portion of the raster without interrupting the show.

In the past, such special effects have been most frequently accomplished with optical techniques. Systems of mirrors and sliding shutters were used to combine pictures. Background projection is sometimes used to provide a suitable setting for live shows. The results obtained in the motion picture industry in the form of wipes, fades and dissolves were desirable but most of the motion picture techniques were not applicable to live television shows, since they depended upon film splicing operations which were time consuming.

By **E. M. GORE**

Television Terminal Equipment Engineering

Electrically accomplished special effects are particularly desirable because of their increased speed. Fades, dissolves and superpositions are simple examples of electrical TV program effects now in common use. In some equipment, the fades and dissolves have been accomplished at controlled speeds by means of electrical circuits. Electrical division of the raster into two separate areas by a straight line for displaying two independent video signals is another effect which has been sometimes employed. A major difficulty which has prevented the combination of signals from widely separated cameras, driven by independent synchronizing generators, has been the lack of control of the relative frequency and phase of the synchronizing signals. Partial solution of this problem has recently been achieved by RCA engineers through the development of the "Genlock." (refer to BROADCAST NEWS, No. 58.)

"Effects" Considerations

Several possibilities of combining two video signals have been investigated. It is desirable to have some means of blanking out one video signal from any one or more areas of a given picture so that video information from another signal can be inserted if desired. It also is desirable to separate these areas with a boundary of any desired shape and to be able to move or change the shape of the boundary without interruption of the video signals.

These latter considerations indicate that a purely electrical blanking system is not widely applicable. Even though simple boundaries can quite easily be generated, irregular boundaries of predictable shape require impractical complex circuits. A suitable type of optical-electrical system can meet the requirements on the boundary shapes because optical masks can be easily cut to the desired configuration.

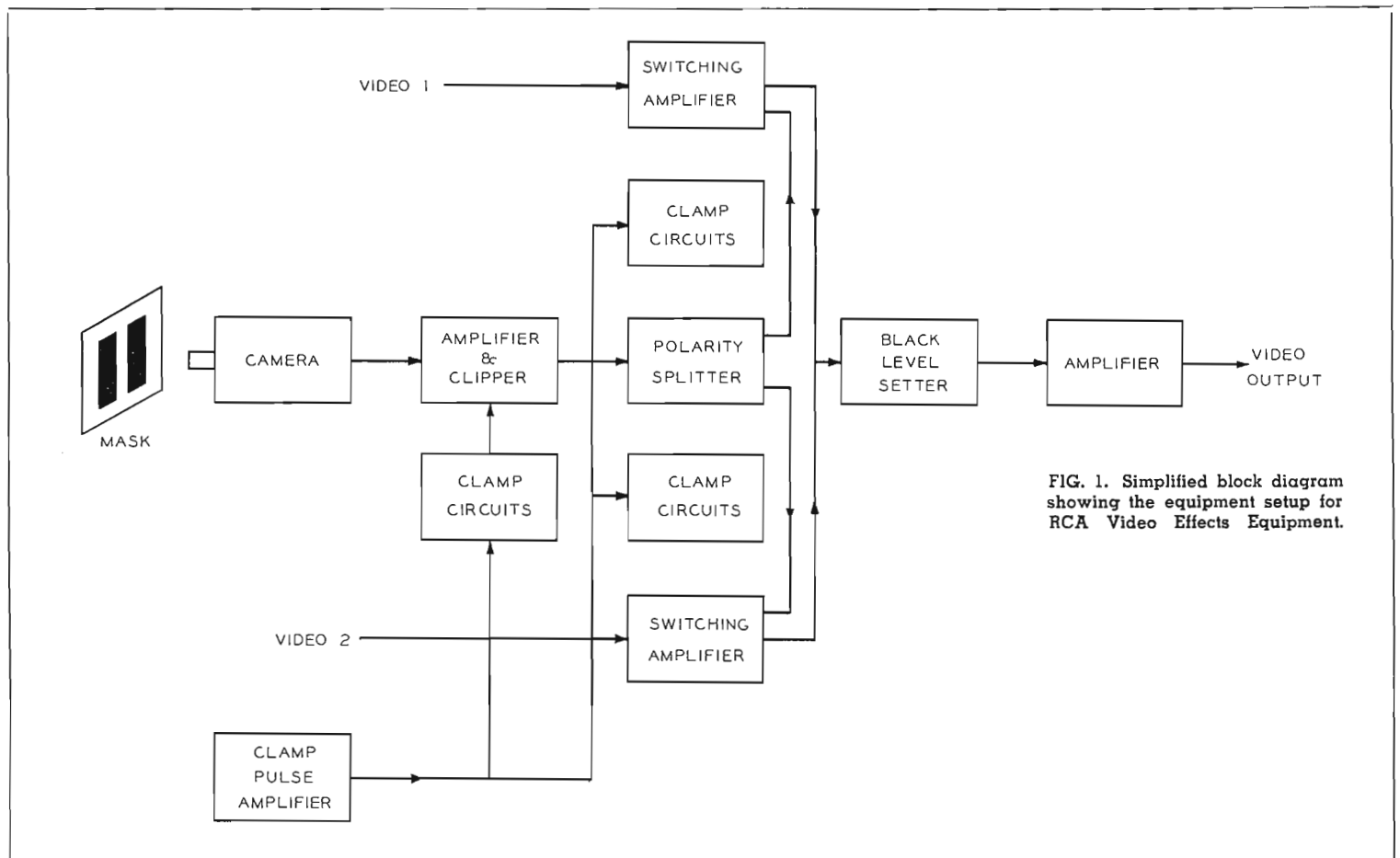

FIG. 1. Simplified block diagram showing the equipment setup for RCA Video Effects Equipment.

Description of New "Effects" System

The basic system which was developed by RCA engineers is shown in the block diagram of Fig. 1. It is designed to blank out any desired portion of one video signal and to replace it with the corresponding portion of a second video signal according to the shape of an optical mask. A television camera is used to generate a switching signal defined by the mask. This camera may be of the flying light spot type where the mask is scanned optically or it may be the conventional television camera where an electron image of the mask is scanned with an electron beam.

The signal from the camera which is used to generate the switching function would ideally consist only of two distinct values—one value corresponding to white areas and the other to black areas of the mask. Because of the presence of noise, stray light and other factors, the camera output signal has much gray information, even when the camera views areas which are black and white. Therefore, this signal is fed into amplifiers and clippers—the output of which is a squared wave with very fast transitions. The output of the clipper is fed to a polarity splitter to provide two outputs of opposite polarity. These two outputs constitute the switching signals.

The switching signals are used to control two switching amplifiers—one for each of the video signals to be switched. These amplifiers are so adjusted that only one of them transmits video information at any one instant. The amplifier which transmits depends on whether black or white areas of the mask are being scanned.

The outputs of the switching amplifiers are combined in a common load resistance and the black level is set by a clipper. The necessary amplifiers are included to provide the correct signal amplitude and polarity into a coaxial cable. This single video output can be fed into a switcher and treated as another signal source.

In order to maintain the d-c component of the video and switching signals, several clamp circuits are employed. These permit movement of the mask or change of the mask while the output signal is being viewed as well as allowing for change of the average level of the video information.

Illustration of Operation

The series of sketches (Figs. 3, 4, 5, 6, 7 and 8) illustrates the manner of operation of the system for a masking signal which is generated by two vertical white stripes on a black background. All of the waveform sketches are for a single line

FIG. 2. Closeup view of the video effects equipment which is contained in a bathtub type chassis for rack mounting.

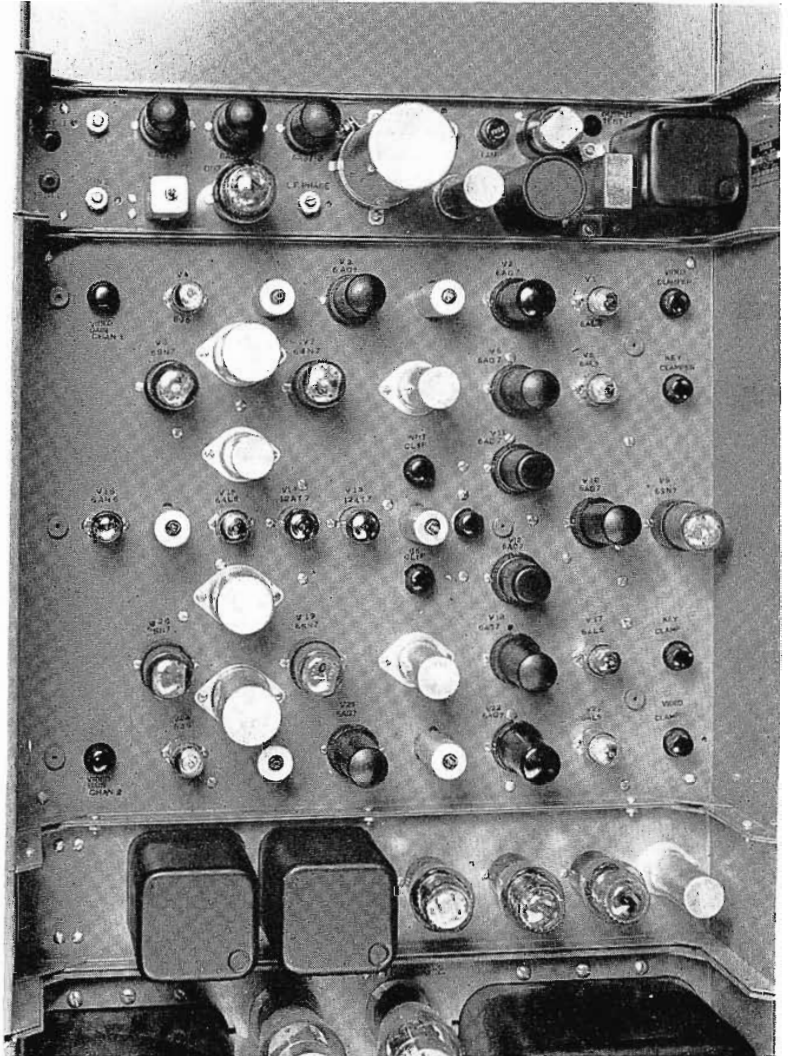
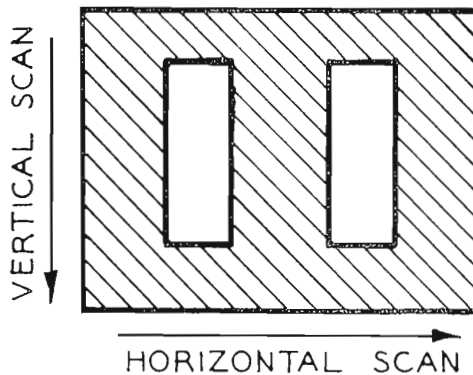

FIG. 3. This sketch of a simple mask (as used with the Flying Spot Camera) plus the waveform sketches of Figs. 4, 5, 6, 7 and 8 illustrate the "Effects" system operation.



interval. Note that portions of the line of video #1 are blanked out and that these blanked portions are filled in with information from video #2.

Development Model

A photograph of a development model is shown in Fig. 2. It was constructed on a 14-inch chassis and a 3½-inch chassis which were bolted together and the circuit required 27 tubes. In this model, the two switched video signals were combined in a TA-10A mixing amplifier which is visible at the top of the photograph.

A few of the effects which may be performed with this system are shown by the accompanying photographs which were taken from a monitor kinescope. A flying spot scanner and opaque masks were used to generate the switching signals.

Fig. 9 is a series of photographs demonstrating a horizontal wipe where the first picture was progressively replaced by the second picture as the mask was moved through the flying spot scanner. It should be noted that there is no restriction on the shape of the mask used for wipes nor on the direction in which the wipes are made.

Fig. 10 is a series of photographs illustrating the replacement of an area of one picture with picture information from the corresponding area of a second signal. A keyhole slot was used as a mask for a special effect.

Figs. 11 and 12 illustrate the use of masks of particular shapes to impart additional information to the viewer. In Fig. 11, a sharp pointer was placed in the focal plane of the flying spot scanner and was easily moved to designate points of

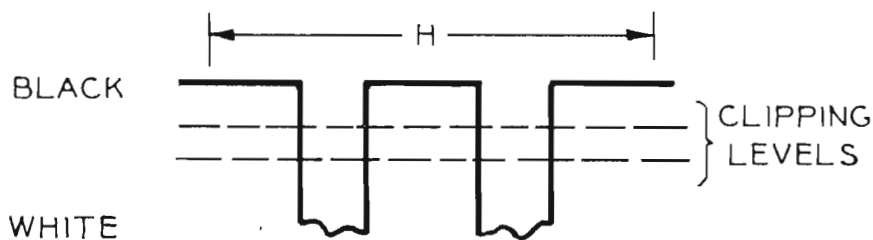

FIG. 4 (above). The output signal from the Flying Spot Camera appears as shown here, with black positive.

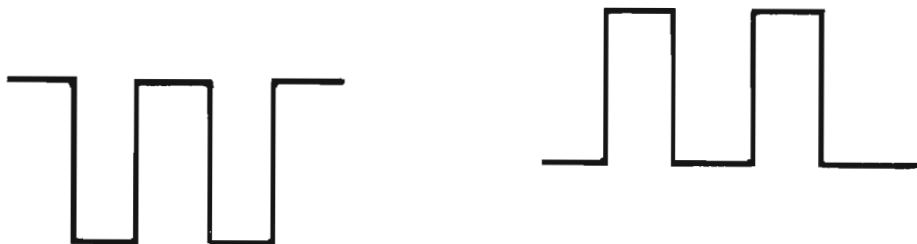

FIG. 5 (above). As indicated in this waveform sketch, the signal is clamped and clipped (clipping levels are adjustable). The clipped signal is fed into the polarity splitter, yielding outputs of opposite polarity.

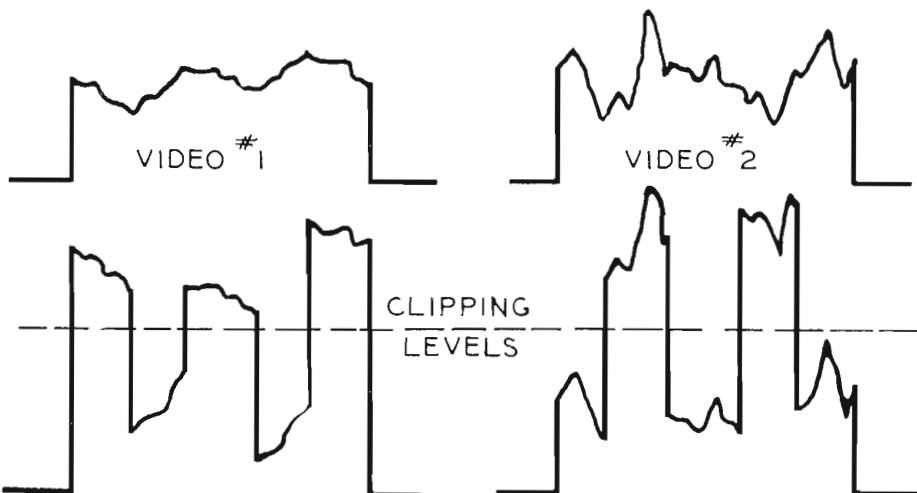

FIG. 6 (above). These waveforms illustrate how the two switching signals are clamped during the blanking interval and are mixed with their respective video signals (video signals are also clamped).

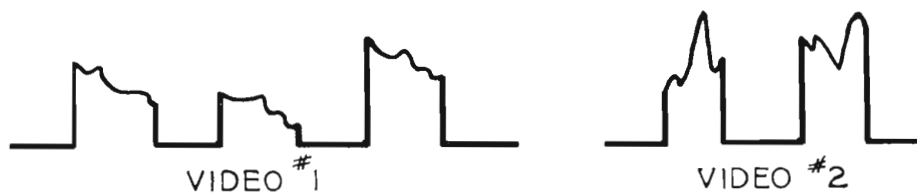

FIG. 7 (above). The useful portions of the mixed video signals are those shown in the waveform diagrams above.

COMPOSITE OUTPUT SIGNAL

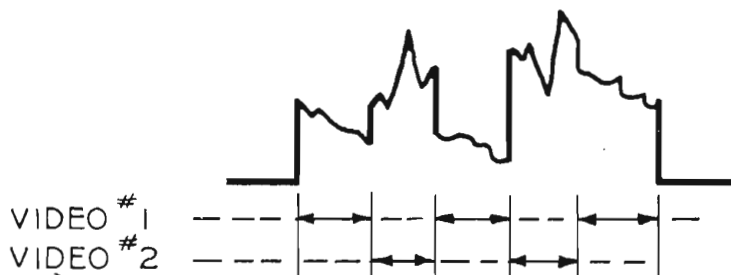

FIG. 8. Finally, the two signals are mixed in an amplifier to obtain the desired composite signal, as shown here. In this case, the video signal #1 is displayed when the flying spot is behind the mask. Video signal #2 is displayed when the phototube is illuminated by the flying spot. (Black level is set to the desired level by means of a clipper.)

interest in the picture. In Fig. 12, the arrow was cut into the opaque mask. The second video signal was black for both Figs. 11 and 12. The photographs in Fig. 13 were made using a crudely cut mask and several different types of video information for the second signal. Many effects are possible, such as wedge, diagonal, or vertical division and keyhole insertions of either polarity. Each of these masks may be used for wipes as well as for fixed divisions. The mask shapes are limited only by the imagination of the producer or program director.

Associated Equipment

Although most of the work on this system has been done using flying spot cameras to generate the switching signals, studio and film cameras have also been used successfully. The principal requirements of the camera signal are that it be capable of reproducing the edges of the mask to the required degree of accuracy and that a noise-free switching signal can be derived from it by clipping.

Some form of switching system at the video inputs of the special effects equipment may be desirable so that any two video signals may be introduced. Interchange of the blanked out and the transmitted portions of the two video signals may easily be accomplished by interchange of the input video lines although it is also possible to accomplish the same result by reversal of the switching signal polarity.

Masks may be cut out of suitable paper and placed on a contrasting background when using a studio camera or opaque projector for generating the switching signal. For cameras using transparencies, the masks may be cut from opaque paper or cardboard or opaque markings may be made on glass or plastic. A means of providing smooth controllable movement of the masks is desirable when making wipes or other movements of the blanked areas of the raster.

The use of the "Genlock" makes possible the combination of remote and of network programs with the local programs. In any case, the video signals and the switching signals used must all be precisely synchronized at both field and line rates.

Acknowledgment

Credit for assistance and advice during the development of this equipment is due H. N. Kozanowski, J. D. Spradlin, J. H. Roe and to other engineers in the Television Terminal Equipment Engineering Section.



FIG. 9. These photos taken directly from the monitor screen illustrate how horizontal wipes may be used in progressive steps or continuously. Many arrangements can be made up from any two program sources.

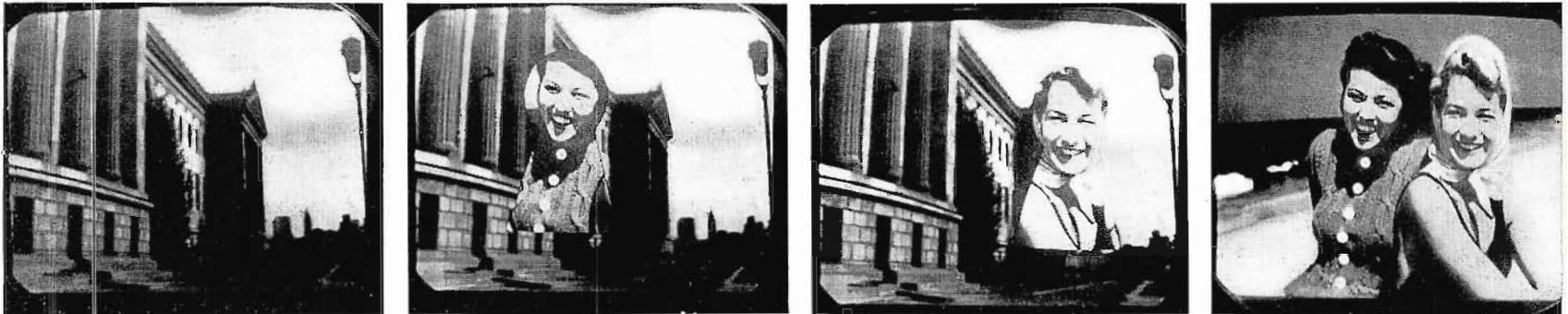

FIG. 10. Dramatic video effects may also be obtained when an area of one picture signal is replaced by that of a second signal. Any form of cutout (as the keyhole effect above) may be used.

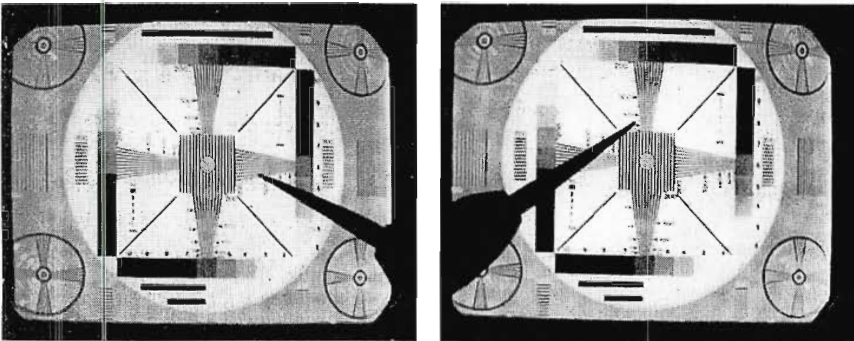

FIG. 11. A sharp, pointed object may be used effectively to emphasize points of interest in a scene. The pointer may be moved to any position.

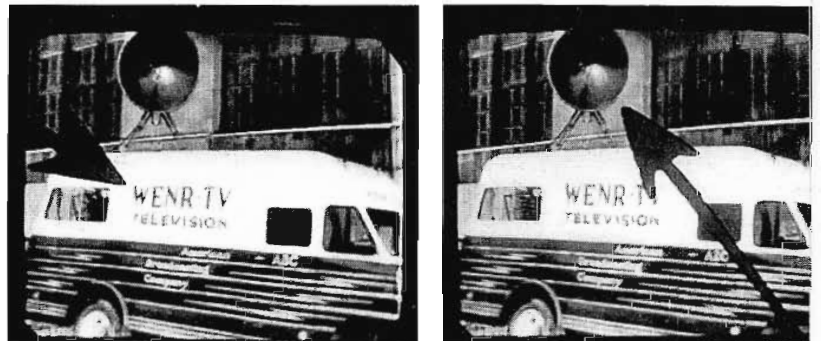

FIG. 12. In the pictures above the arrow or pointer is cut into the opaque mask. The background signal is black for these pictures and for those shown in Fig. 11.

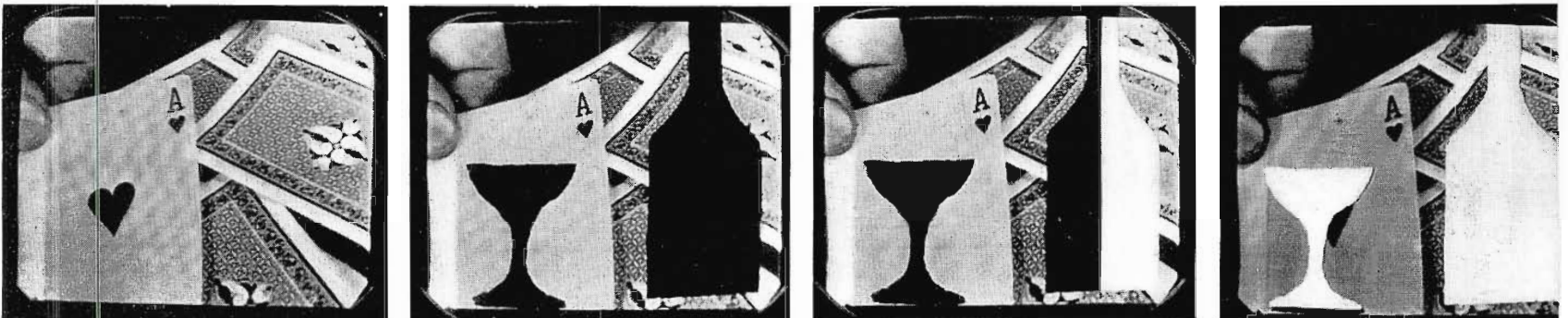

FIG. 13. A crudely cut cardboard mask serves to illustrate how a variety of effects may be produced. These shapes can be made to appear all black, all white or in "black-and-white" combinations.

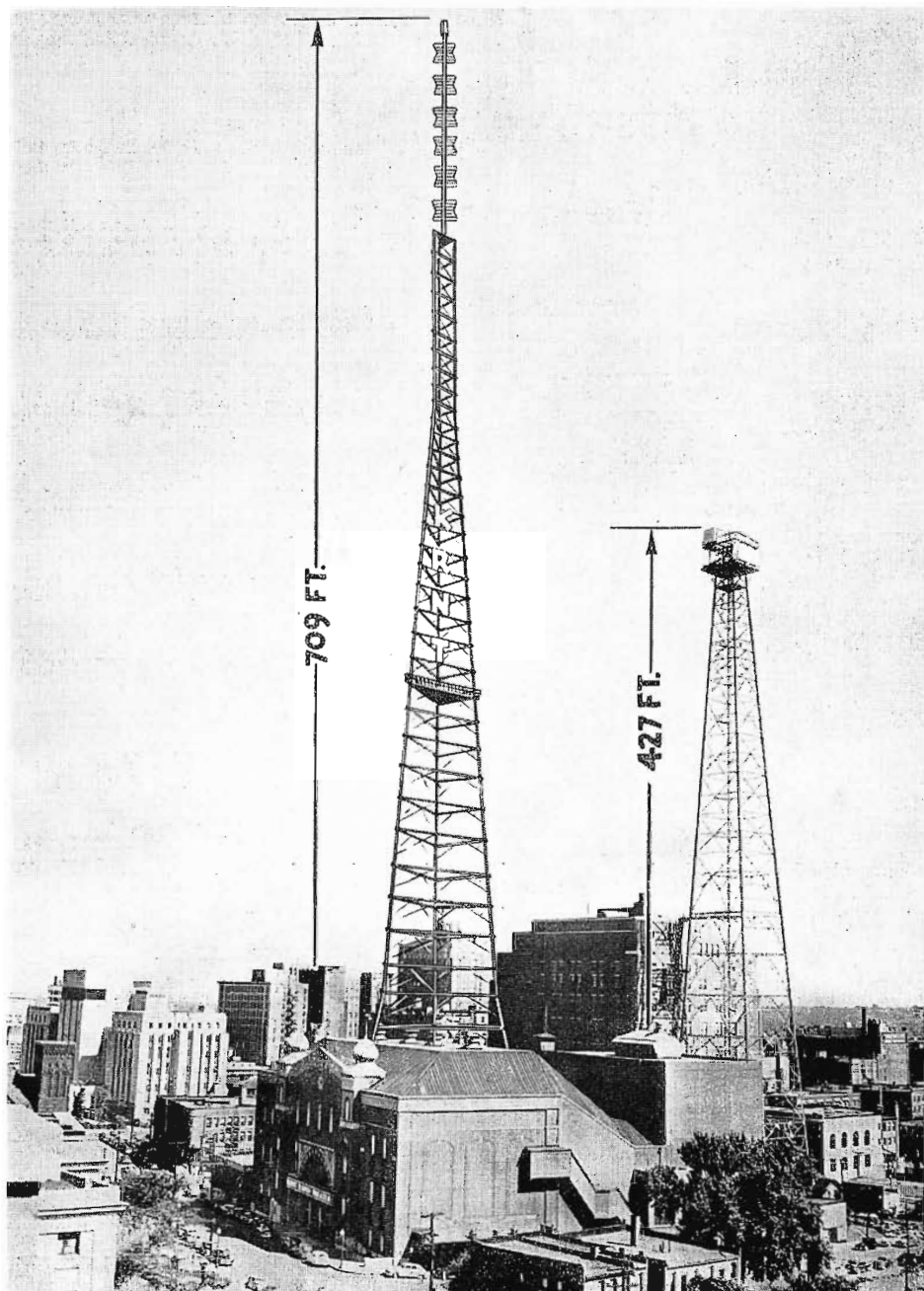

Photo-sketch showing the 709-foot KRNT FM-TV tower under construction in Des Moines. The structure is just a half-block from the Bell microwave relay tower. There is no relation in the proximity of the Bell tower, however, since any future network TV programs would be transmitted by cable.

Mr. Charles Quentin, Chief Engineer of KRNT, who was instrumental in planning the new KRNT tower installation.



KRNT 709-FOOT TV TOWER UNDER CONSTRUCTION

The foundation structure of a 709-foot tower for KRNT, Des Moines, has been completed. The new tower is being erected above the KRNT Theatre, and will be used to radiate FM and, ultimately, TV.

According to Mr. Robert Dillon, Vice President of Cowles Broadcasting Company, erection of the tower is another step in the fulfilment of long range plans to move KRNT studios into the theatre building to form a radio, stage, concert, and

TV entertainment center. KRNT's present FM antenna is atop the Register and Tribune Building. KRNT's AM transmitting facilities, however, will not be affected.

The new triangular self-supporting tower will support a six-section RCA Super Turnstile, which will eventually be used for TV broadcasts. A $6\frac{1}{8}$ -inch transmission line will extend approximately 600 feet from the base of the tower to the FM antenna which will be mounted on the side of the

tower. Two $3\frac{1}{8}$ -inch lines to feed the Super Turnstile will be added when TV broadcasting begins.

In addition to the arrangement for supporting the TV Super Turnstile, provision has been made for the addition of several Super Gain TV Antennas. These will be installed in the same manner as those for Empire State Building in New York City. This will allow several Des Moines TV stations to share the advantages of the KRNT tower.



Important Announcement To All Radio Hams!

Here's some real good news! Beginning in our next issue we shall have space in BROADCAST NEWS . . . space reserved just for *us*—all hams in broadcast and at RCA as well.

Our special section will be called "HAM FORUM". How do you like the handle? It was suggested by Ed Jones, an old timer right here in our office. (Some of you no doubt worked Ed back in the days of the rotary gap, when he was 5QW in New Orleans.)

There are lots of you out there in the broadcast business. Through HAM FORUM we can get acquainted and exchange a few ideas. Maybe you have a photo of a new rig just put on the air, a schematic of a special improved circuit, news about your local radio club, or a photo of yourself.

Send us the "dope"—anything you think will be of interest, with your call letters and the band you work. Address all information to HAM FORUM, in care of Marvin L. Gaskill, Associate Editor, Broadcast News, RCA, Camden, N. J.

73
MARVIN L. GASKILL
W2BCV



4 new bulletins

on **RCA 2-WAY RADIO**
STATION EQUIPMENT

...containing detailed descriptions of a complete line of equipment—transmitters, receivers, control consoles, accessories—for that most important part of your two-way radio system, the headquarters station.

...includes eight different transmitter models with powers of 15, 60, 70, 250 and 3000 watts, frequencies of 30-50 mc and

152-174 mc. Choice of cabinets and control consoles, local or remote. Complete electrical and mechanical specifications to help you place a complete installation of the most modern type.

For free copies of these handy references, simply mail the coupon. (In Canada, write RCA Victor, Limited, Montreal.)

RCA Engineering Products, Camden, N. J. Dept. P-150.

Send me the following books on RCA 2-way Radio equipment:

- 3000-watt State Police Equipment (42-45 mc) Fleetphone Station Equipment (30-50 mc)
 A-c Carfone, 15-watt Portable (152-174 mc) Carfone Station Equipment (152-174 mc)

Name _____

Firm or Organization _____

Address _____

City _____

State _____



RADIO CORPORATION of AMERICA

THE REQUIREMENTS OF TELEVISION STATION DESIGN

By DR. WALTER J. DUSCHINSKY*

PART III

From Planning to Architectural Interpretation

Few of today's existing television stations can trace their ancestry back to an over-all, clear-cut, thoroughly worked-out master plan. On the contrary, most of them are "quickie" modifications of AM studios or other existing areas. In most cases the original thought was that these studios would be purely temporary. Suddenly, however, the TV boom transformed these temporary setups into permanent operating installations—with certain unfortunate results. Faults and shortcomings in station design, which were perfectly recognizable but minor matters during the days of experimentation, became frozen into the pattern of commercial operation. And insignificant though these may have been in the early stages, they now bulk large as stumbling blocks to the industry's economic success.

Similarly, newer stations which hadn't gone through the early stages were built with much repetition of the mistakes of older installations. Of course, certain of the more glaring inadequacies were eliminated. But major errors remain, stemming on the one hand from an uncritical copying of older facilities and on the other hand from improperly conceived design.

LIMITATIONS OF TODAY'S TV STATIONS

Even more damaging is the fundamental trouble stations are now encountering or will encounter as they try to expand. For, as is generally recognized, the future profitability of telecasting lies in its potential expansion; and the ease with which that

expansion can be carried out depends in great measure upon the adaptation and flexibility of existing stations. Yet, here is a basic weakness in our existing facilities: fixed and frozen in their areas and concepts, they display the work of a stale imagination where, in the new TV field, one would expect a fresh approach. Worse still, these frozen facilities have imposed a disorganized pattern on all aspects of station activity, thereby making expansion unnecessarily costly and needlessly wasteful.

The failure of TV station design to concern itself with over-all planning can be listed in five major particulars:

1. Lacking a complete master plan to encompass present requirements and future development, most stations have gone into commercial telecasting with makeshift plant and equipment. Trial and error, though vital to research and experimentation, when carried over into the commercial field is proving an expensive and inefficient way of doing business. In the headlong rush to begin or expand operations, reliance on make-do facilities—conceived originally for other purposes—has been demonstrably unsatisfactory. For make-do not only places serious and artificial limitations on program production; it is also an exceedingly temporary expedient—so temporary that these facilities are often outdated or outgrown at the moment of their completion.
2. In the absence of planning, primary station areas—technical operation, production, administration and maintenance—are grouped together without consideration of the separate functions of each, or of the interrelationships of all. For example, instead of careful integra-

tion, production areas are often interspersed with administrative offices—to the detriment of both types of activity. The potentialities of excellent engineering systems are frequently reduced by the inferior studios which they are supposed to serve.

3. Because traffic-flow patterns have generally been ignored, most stations have lost valuable space and been plagued by unnecessary confusions (which add up to lost time and wasteful motion). So too, no attention has been paid to the relationships between horizontal and vertical traffic.
4. Equipment purchases have sometimes been haphazard and opportunistic, with little thought either to standardization or specialized station requirements.
5. Further development of production, operational and administrative areas is usually impossible or excessively costly merely because such development was not contemplated or planned for in the beginning.

Today, control areas have become rigid, sightlines are fixed, and camera positions predetermined. Contemporary studio layouts show a stubborn adherence to unchangeable proportions between the studio and its control booth, storage areas, light bridge and auxiliary areas. And unfortunately, this stubbornness forces a station owner who must multiply his studio area to multiply everything else—whether or not there is reason for such over-all expansion. Thus, a need to increase facilities calls for unnecessarily heavy new investment and produces a multiplied plant which is less efficient because of its duplications and expensive to operate.

* 425 E. Fifty-third Street, New York 22, N. Y.

EDITOR'S NOTE: This is the third part of a four-part article written especially for BROADCAST NEWS by Dr. Duschinsky, well-known consultant on television station design. Parts I and II appeared in the last two issues of BROADCAST NEWS, and Part IV will appear in the next issue.

It should be noted that this series of articles is not intended to furnish a blueprint which can be followed in TV station design—nor to serve as a check list on planning, although it has some aspects of the latter. The purpose,

rather, is to picture in a broad way the problems incident to station design—and to emphasize the place and importance of overall planning. It is the author's opinion that this planning should be done by someone with considerable experience in large-scale industrial design in general and TV station design in particular. The series is written almost entirely from that viewpoint. Nevertheless, we feel that the ideas expressed by Dr. Duschinsky apply in a general way to all station design and, therefore, will be of interest to all.

T.V. PLANNING.

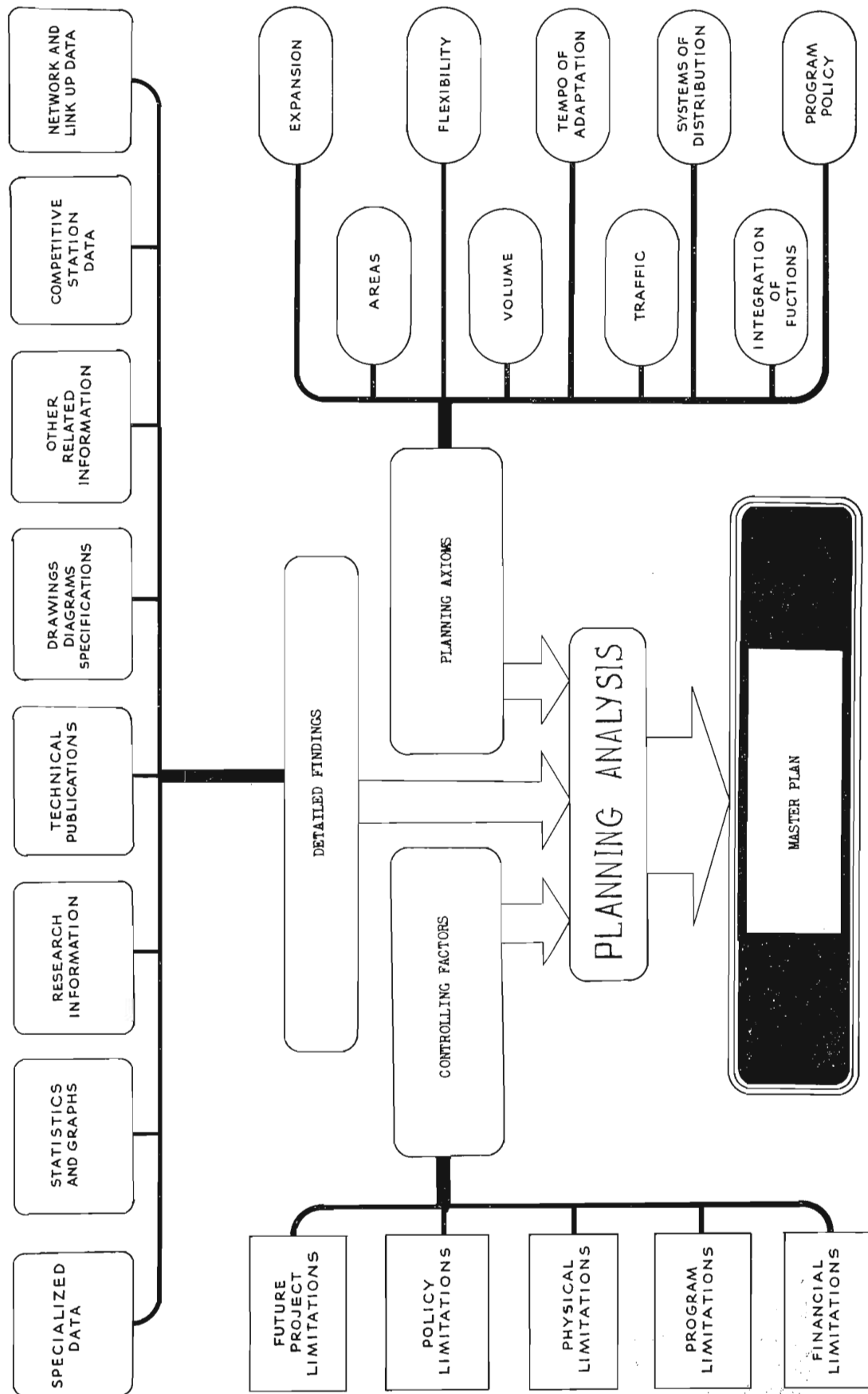

TR

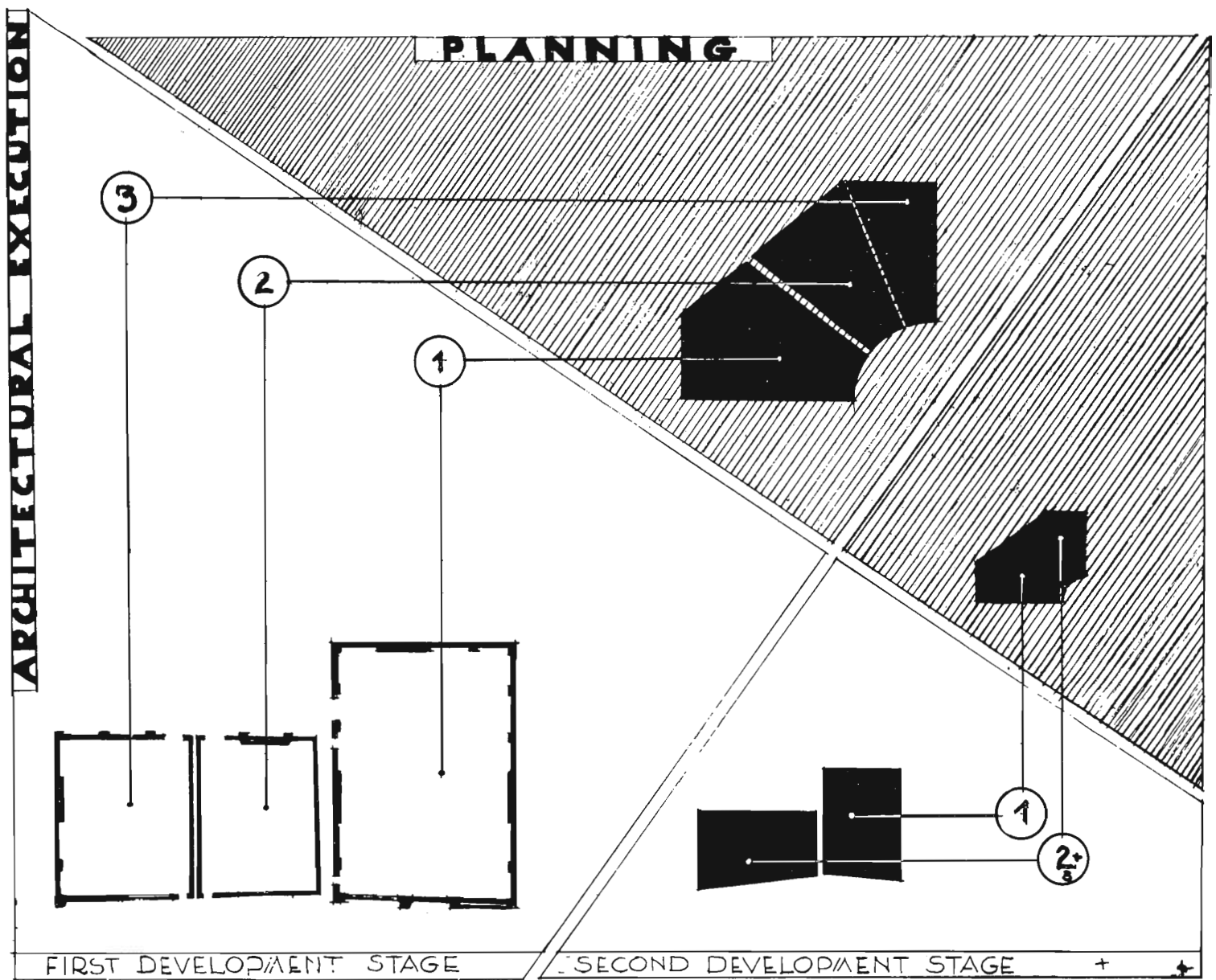

① L.T. STUDIO NR. 1

② L.T. STUDIO NR. 2

③ L.T. STUDIO NR. 3.

PLANNING PROVIDES FOR EXPANSION

In contrast, when a TV station has been built according to a master plan—made by a skilled planner *before* the architect draws his plans—it will be relatively easy to expand the station's facilities as the programming requirements increase. Moreover, such expansion, because it does not employ straight forward multiplication of *all* facilities, will increase, rather than decrease, the efficiency of the operation. Thus production costs will go down, rather than up, as business increases.

The general problems of station planning, as well as the tools which the planner uses in solving these problems, have been discussed in previous sections. Fig. 1 indicates in diagrammatic fashion how all of the factors and considerations are

brought together in a planning analysis to produce an over-all master plan which, once completed and agreed upon will be used as a guide by the station's architects and engineers. Fig. 2 and Fig. 3 indicate how the architect will develop his floor layout plans from the master plan. In doing so he will, of course, take into account the limitations imposed by a building site, the nature of the community in which it is located, and other local factors which may not have been fully accounted for in the original plan.

ARCHITECTURAL INTERPRETATION

Successful carrying out of the master plan requires close coordination between planner and architect in the architectural translation of the master plan. Final architectural form is usually dictated by structural engineering requirements.

Fig. 4(a) pictures a well-balanced scheme for the ground-floor area of an originating station. Translated without imagination by a structural engineer who thinks in conventional concepts, the planner's scheme takes the shape of the actual floor plan in Fig. 4(b).

Here, the defects of a conventional approach are apparent. Traffic separation—one major goal of planning—has been achieved. But the structural skeleton with badly spaced columns in the studio area prevents proper placement of the adjacent control-room areas. By using small spans and deep girders, structure has not been harmonized with function, for TV production requires large spans if studios are to be put to truly functional use. Therefore, structural plan B is neither adequate nor economical.

PLANNING LAYOUT

(A)

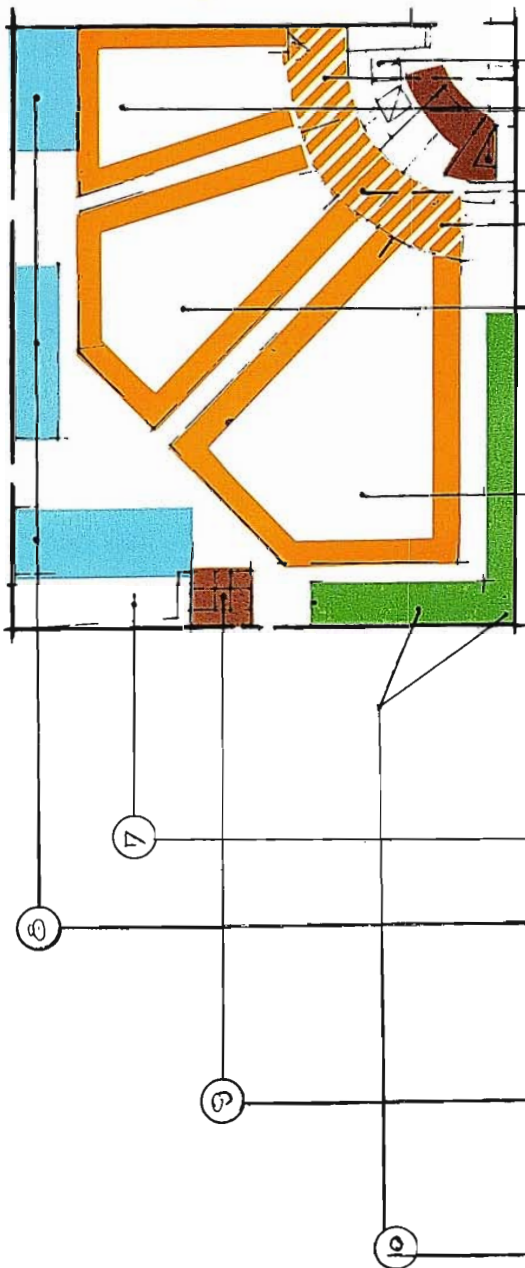

- ① T.V. STUDIO No.1
- ② T.V. STUDIO No.2
- ③ T.V. STUDIO No.3
- ④ STUDIO CONTROL ROOM No.1
- ⑤ STUDIO CONTROL ROOM No.2
- ⑥ STUDIO CONTROL ROOM No.3

- ⑦ VERTICAL MATERIAL TRANSPORTATION
- ⑧ STORAGE
- ⑨ VERTICAL PRODUCTION TRAFFIC
- ⑩ PRODUCTION OFFICES
- ⑪ VERTICAL ADMINISTRATIVE AND TECHNICAL TRAFFIC

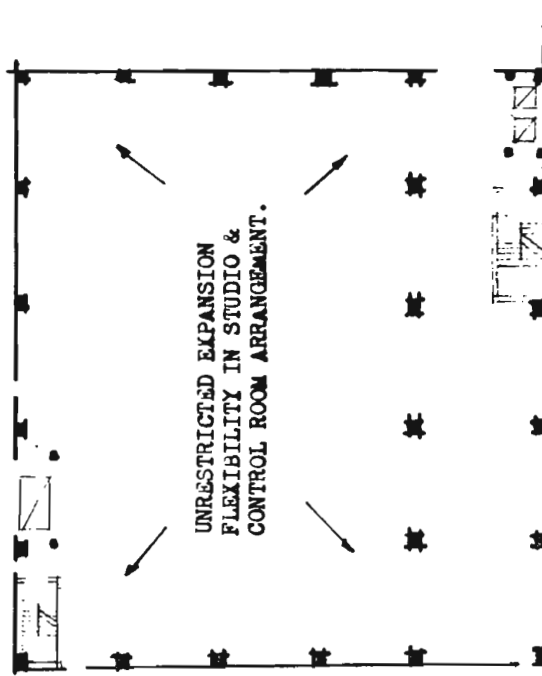

UNRESTRICTED EXPANSION
FLEXIBILITY IN STUDIO &
CONTROL ROOM ARRANGEMENT.

(C)

**ARCHITECTURAL LAYOUT
WITH FUNCTIONAL DESIGNED LARGE SPAN
SKELETON.**

(B)

**ARCHITECTURAL LAYOUT
WITH CONVENTIONAL RESTRICTIVE STEEL
SKELETON.**

FROM PLANNING TO ARCHITECTURE

PLA

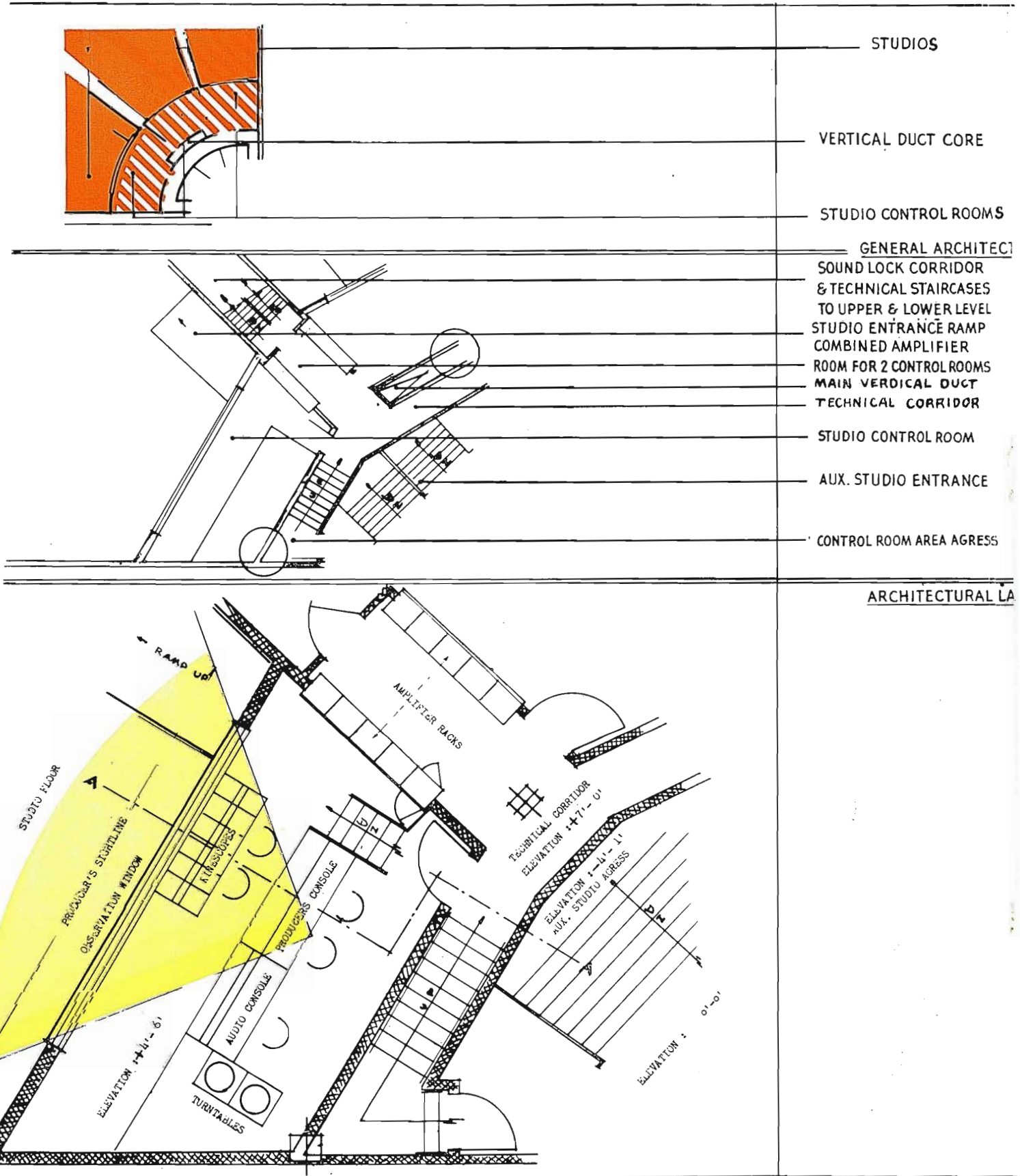

TECTURAL INTERPRETATION.

ANNING

MAIN CONSIDERATIONS

PROPER RELATION OF AREAS
VOLUME
TRAFFIC SEPARATION
& FLOW
DISTRIBUTION HORIZ. &
VERT. OF ELECT & MECH.
DUCT SYSTEM

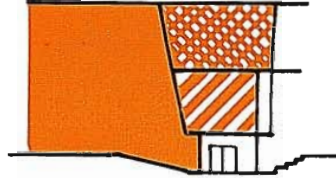

URAL INTERPRETATION

MAIN CONSIDERATIONS

ADJUSTMENT IN THE HORIZ.
& VERT. PLANE FOR THE
STUDIO & STUDIO CONTROL
ROOM
INTERLEVEL ADJUSTMENT
FOR THE CONTROL ROOM
INDICATION TO STRUCTURAL
ENGINEERS FOR PLACING
OF COLUMNS

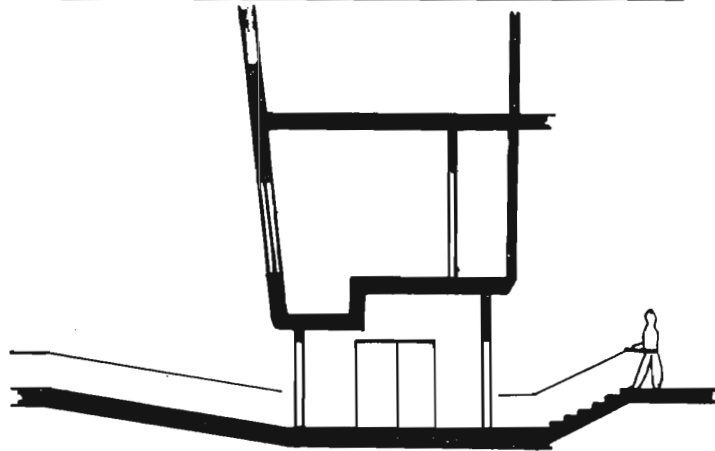

YOUT COORDINATED

MAIN CONSIDERATIONS

STRUCTURAL SKELETON
HAS BEEN DETERMINED
GENERALLY
CONTROL ROOMS HAVE
BEEN DESIGNED TO ACCOM-
MODATE ALL NEEDED EQUIP-
MENT & SIGHTLINES FOR
PERSONNEL HAVE BEEN
DETERMINED
LEVELS ARE CHECKED FOR
PROPER CLEARANCES AND
VERTICAL VIEWING FIELDS
TECHNICAL TRAFFIC
DENSITY & DIRECTION
DETERMINES BESIDE
CLEARANCES FOR EQUIP-
MENT WIDTH OF PASSAGES

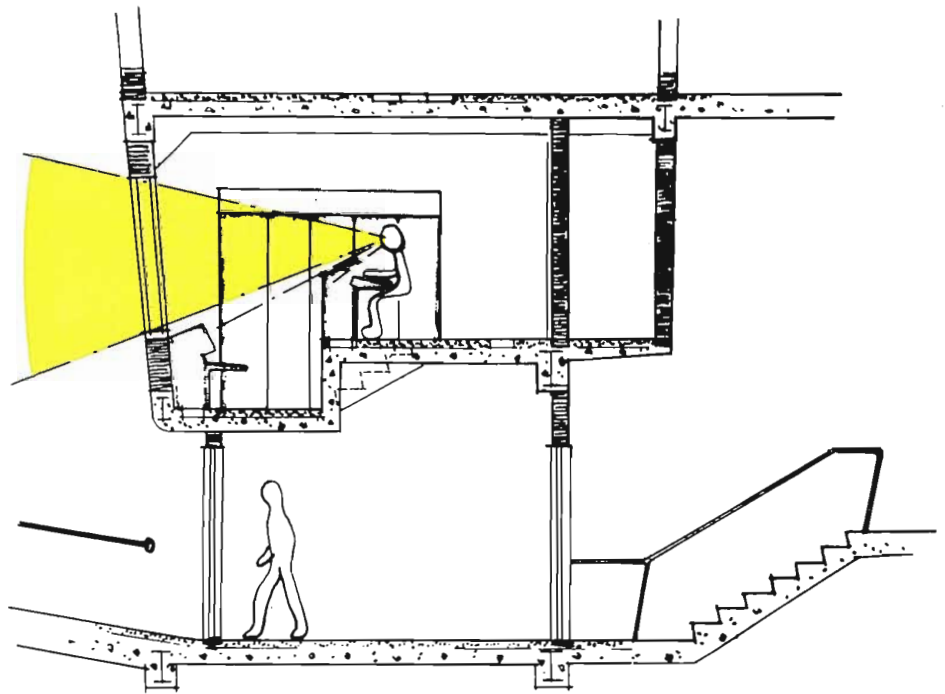

MASTER CONTROL R/A & STUDIO CONTROL RMS

ARCHITECTURAL EXECUTION

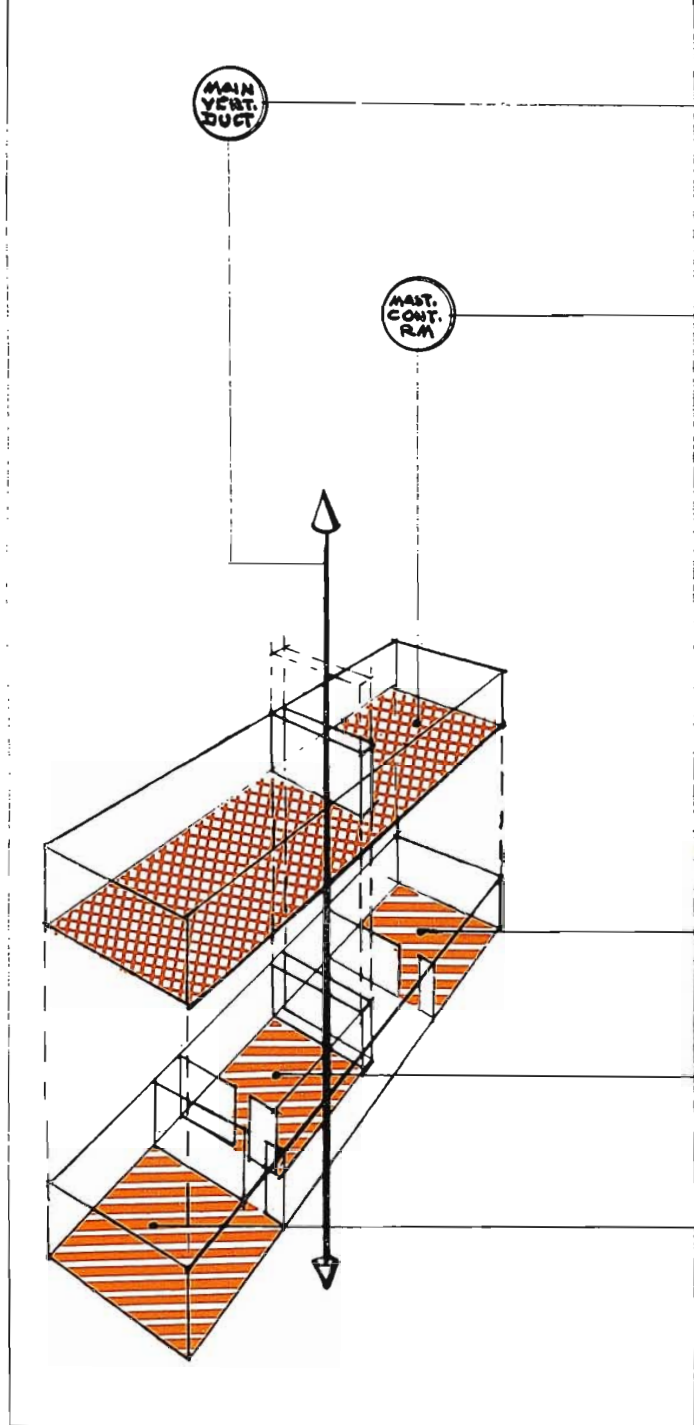

PLANNING

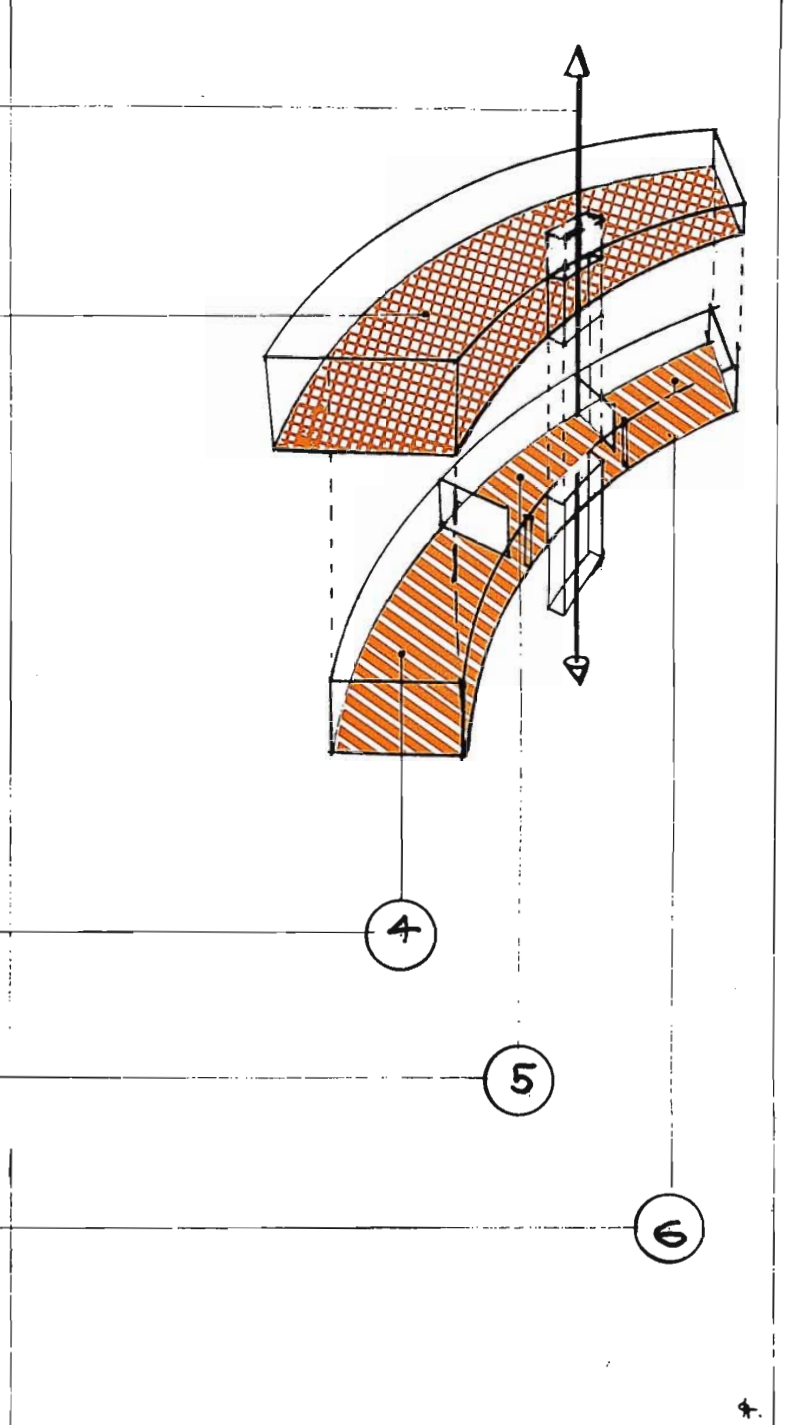

A better functional and economic translation of the planner's scheme would employ truss floors providing more usable space and permitting fuller vertical expansion. This latter use is especially important. Not only do truss floors act as an isolating area between studio cores but they can be developed to house auxiliary production areas and administrative offices.

Assuming the use of truss floors, Fig. 4(c) indicates a simplified transfer of a master plan into architectural execution.

The advantages are obvious. Studio areas are as unrestricted as structural limitations allow and far less restricted than present studios. Expansion by area is comparatively easy and economical.

Although it may seem, at first glance, that the planner is doing the architect's work, this is actually not the case. Fig. 5 (following pages) shows how the planner's general (and greatly simplified) sketches will be translated by the architect into actual building plans. The amount of detail

which must be added is enormous. Moreover, at this point many important details—such as sightlines and clearances—must be carefully checked. During this stage, close coordination between planner, architect and engineer is a necessity. The end result will bear out the early promise only when these three work as a team.

(Part IV of this article will appear in the next issue)

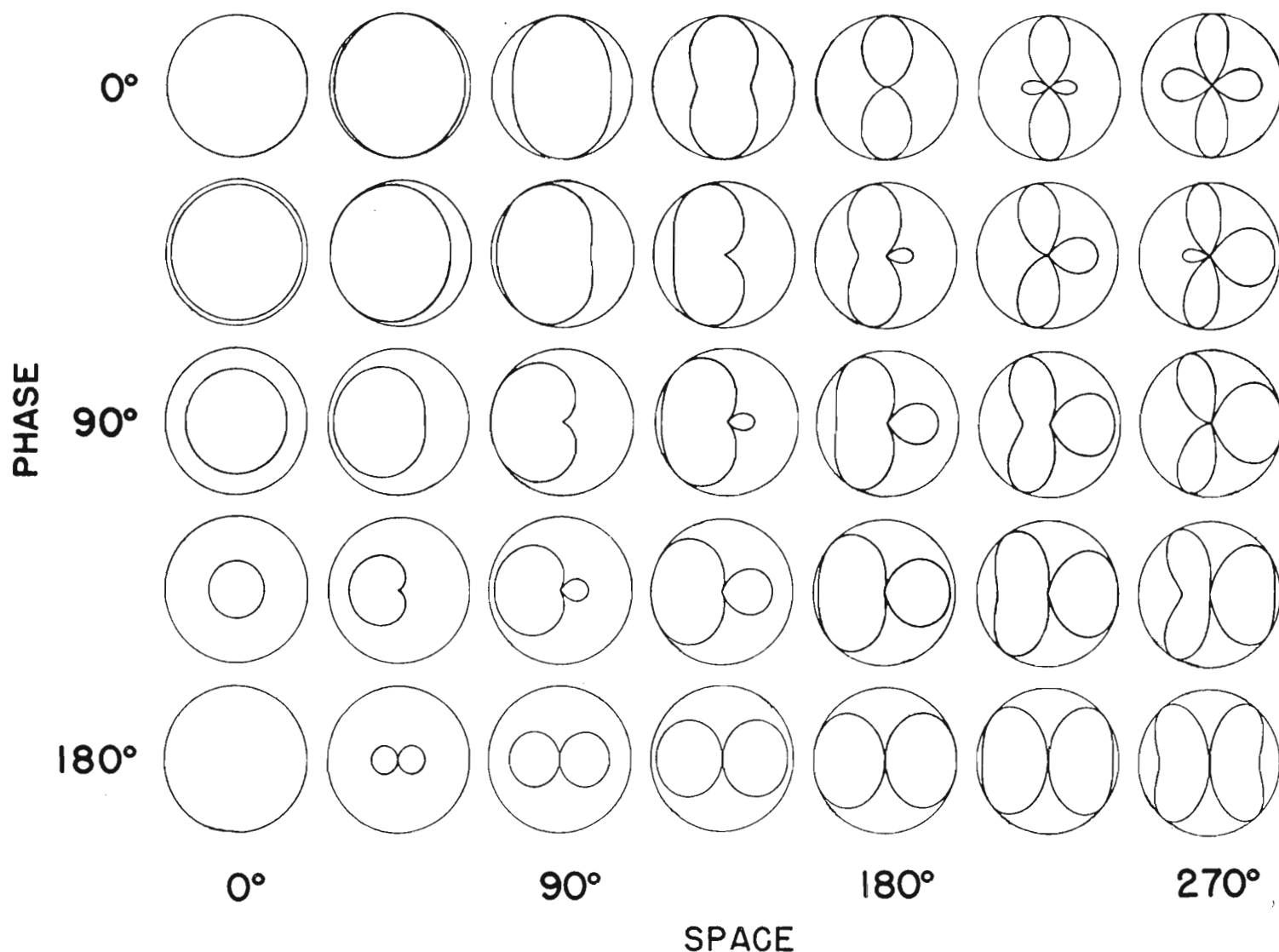

FIG. 1. Horizontal radiation patterns from 2-element directional antennas for various phase and space relationships.

FACTORS EFFECTING PERFORMANCE OF DIRECTIONAL ANTENNAS

By **A. EARL CULLUM, JR.**
 Consulting Radio Engineers
 Dallas, Texas

Preface

Directional antennas are employed to provide protection to other stations and to provide service to the area to be served. A number of factors must be taken into account in designing a directional antenna that will provide proper coverage as well

as proper protection. We will assume during this discussion that these requirements have been satisfied and that a directional antenna pattern has been established.

When the directional antenna pattern has been established, relative magnitude relations and relative phase relations in the system become fixed. There may be several conditions that would establish the pattern, but we will assume that the design engineer has reviewed the various pos-

sibilities and has chosen the optimum design. The actual currents in the elements and the actual fields to be radiated by the elements then become fixed for any given power.

I. Overall Efficiency

In Fig. 1, we have a family of curves showing a few of the patterns that can be obtained from the use of two elements. The design engineer with experience can estimate the overall efficiency to be expected

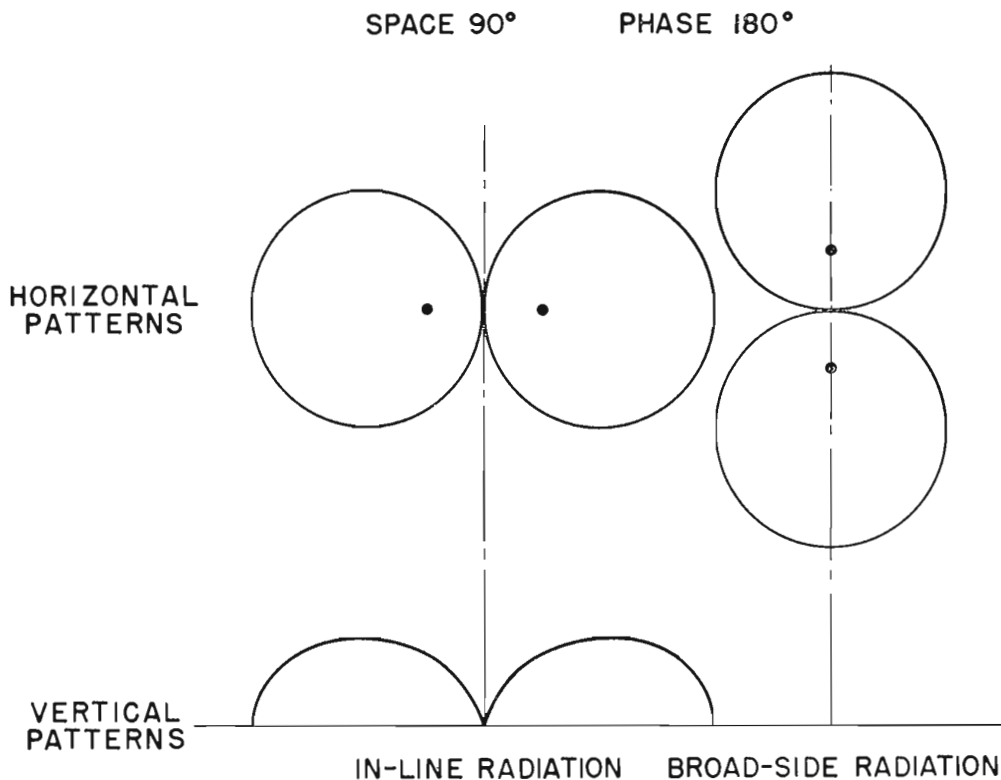

FIG. 2. Radiation patterns from a 2-element directional antenna in which elements are spaced 90 degrees and currents are 180 degrees out of phase. Note the reduced sky-wave radiation and increased ground-wave radiation.

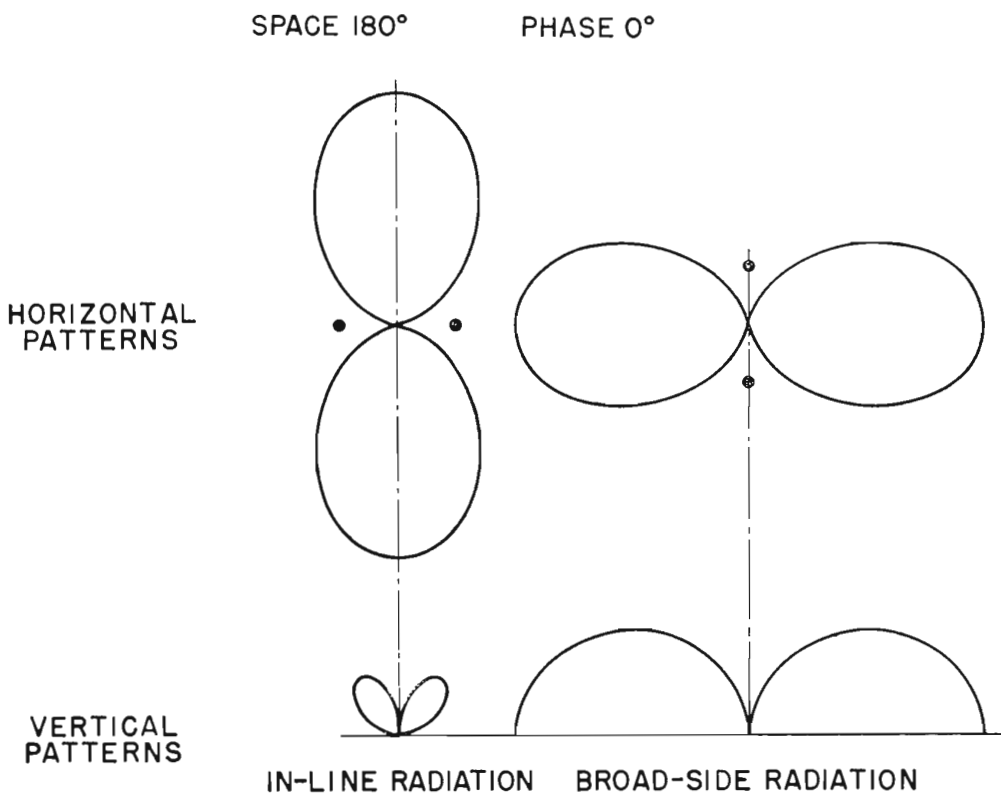

FIG. 3. Radiation patterns from a 2-element directional antenna in which elements are spaced 180 degrees and currents are in phase. Increased sky-wave results in decreased ground-wave.

from the usual 2-element antenna system. The overall efficiency depends upon two factors:

- (a) The actual power radiated by the directional antenna system.
- (b) The horizontal gain of the directional antenna system when compared with a non-directional antenna system.

Thus it can be seen that the actual efficiency of a directional antenna system depends upon the loss and the gain involved.

The actual power radiated can be determined by subtracting all losses from the input power. These losses include the transmission line losses, the coupling equipment losses, and the antenna-ground losses. These losses can be readily determined or estimated by various methods. The horizontal gain of a directional antenna is the ratio of the power radiated from the directional antenna along the ground when compared to the power radiated from a non-directional antenna along the ground. The horizontal gain of a directional antenna can be readily determined or estimated by various methods.

Fig. 2 shows the horizontal and certain vertical patterns for the 2-element system where the elements are spaced 90° and the fields are phased 180°. With this pattern the sky-wave radiations are reduced, which, in turn, cause the ground-wave radiations to be increased. This pattern has more ground-wave power than a non-directional antenna system and thus it is considered to have a gain which is greater than 1. Fig. 3 shows the horizontal and certain vertical patterns for the 2-element system where the elements are spaced 180° and the fields are phased 0°. With this pattern the sky-wave radiations are increased which, in turn, cause the ground-wave radiations to be decreased. This pattern has less ground-wave power than a non-directional antenna system and thus it is considered to have a gain which is less than 1.

We have reviewed the losses and the gains encountered in a number of antenna systems and have tabulated them in a table which will give an idea of the order of magnitude of each. Fig. 4 shows the magnitude of the transmission line losses, the coupling equipment losses, and the antenna-ground losses generally encountered. When these losses are subtracted from the input power, we have the radiated power. If we multiply the radiated power by the horizontal gain, we are then able to determine the relative horizontal radiated power to be expected. Fig. 4 also includes a tabulation of the same figures for

FIG. 4. RELATIVE FIELD INTENSITIES TO BE EXPECTED IN HORIZONTAL PLANE

	<u>DIRECTIONAL</u>	<u>NON-DIRECTIONAL</u>
POWER TO ANTENNA SYSTEM.....	108%	100%
TRANSMISSION LINE LOSSES.....	1 – 10%	—
COUPLING EQUIPMENT LOSSES.....	2 – 10%	—
ANTENNA-GROUND SYSTEM LOSSES.....	5 – 68%	5 – 20%
RADIATED POWER.....	100 – 20%	95 – 80%
HORIZONTAL GAIN FACTOR.....	0.8 to 1.6	1.00
RELATIVE HORIZONTAL POWER.....	133 – 30%	95 – 80%

ABOVE ESTIMATES BASED ON FOLLOWING:

1. POWER DETERMINED BY METHODS OF THE F.C.C.
2. TOWERS HAVING 90-DEGREE HEIGHTS.
3. GROUND SYSTEMS CONSISTING OF 120 RADIALS 90-DEGREES LONG.
4. HIGH HORIZONTAL GAIN FACTOR FOR 4-ELEMENT END-FIRE ARRAY.
5. LOW HORIZONTAL GAIN FACTOR FOR 4-ELEMENT BROADSIDE ARRAY.

FIG. 5. RMS FIELD INTENSITIES TO BE EXPECTED IN HORIZONTAL PLANE

		<u>RELATIVE POWER</u>	<u>RMS FIELD</u>
ASSUME	NON-DIRECTIONAL TOWER 90° HEIGHT 90° GROUND.....	95%	190 MV/M
THEN	HIGH RELATIVE HORIZONTAL POWER PREVIOUSLY DETERMINED.....	133%	225 MV/M
AND	LOW RELATIVE HORIZONTAL POWER PREVIOUSLY DETERMINED.....	30%	107 MV/M
WHEREAS	MINIMUM REQUIRED BY FCC FOR CLASS II AND III STATIONS.....	80%	175 MV/M

a non-directional antenna system. The figures are typical figures to be expected when using $\frac{1}{4}$ -wave towers with the usual ground system consisting of 120 radials $\frac{1}{4}$ -wave long about each of the towers. It will be noted that the relative horizontal efficiency to be expected from a non-directional antenna varies from 80% to 95%, whereas the relative horizontal efficiency to be expected from a directional antenna may vary from 20% to 186%.

Fig. 5 indicates the radiated fields to be expected from various antenna systems tabulated on Fig. 4. We have assumed that 100% efficiency is obtained when one uses a $\frac{1}{4}$ -wave tower with a no-loss ground system and receives an r.m.s. field of 195 millivolts per meter at one mile. On this figure, we have listed the minimum r.m.s. field accepted by the Federal Communications Commission for Class II and Class III stations. From the above, it can be seen

that the efficiency of a directional antenna system should not necessarily be expected to have the same efficiency as that of a non-directional antenna. In view of this situation, it is desirable that, before a directional array is constructed, careful consideration be given to overall losses and gains so as to be certain that the overall efficiency of the completed array will be adequate to provide the predicted results.

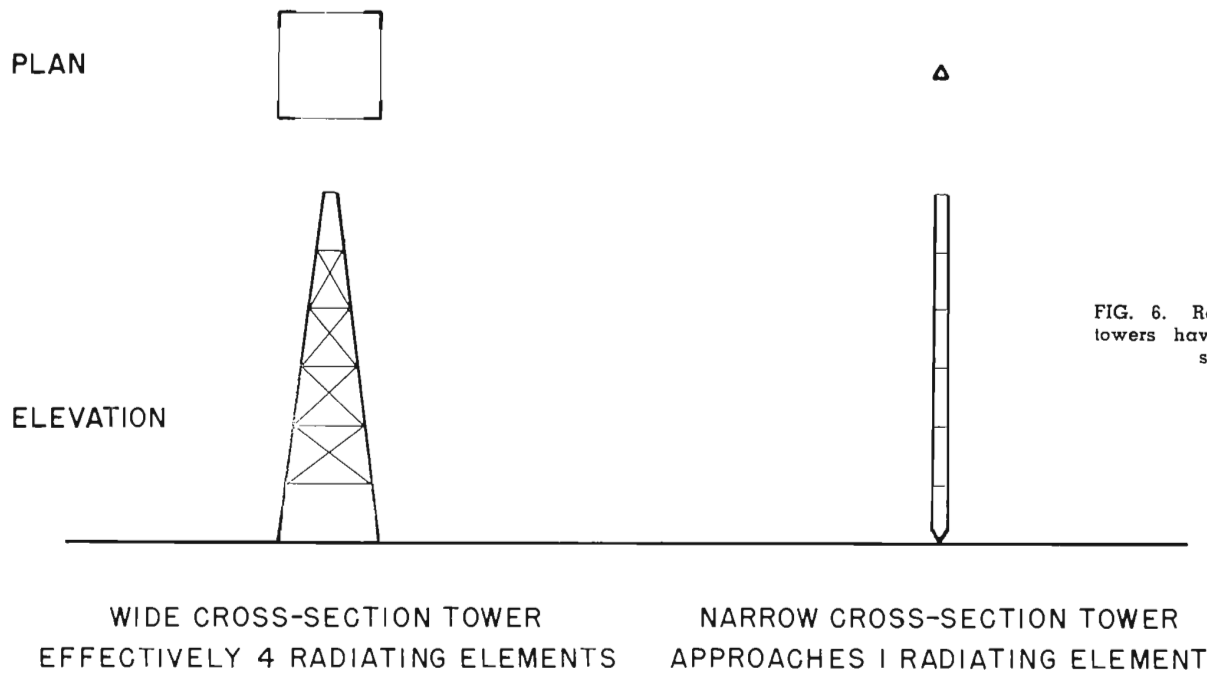

FIG. 6. Radiating elements in antenna towers having wide and narrow cross-sections, respectively.

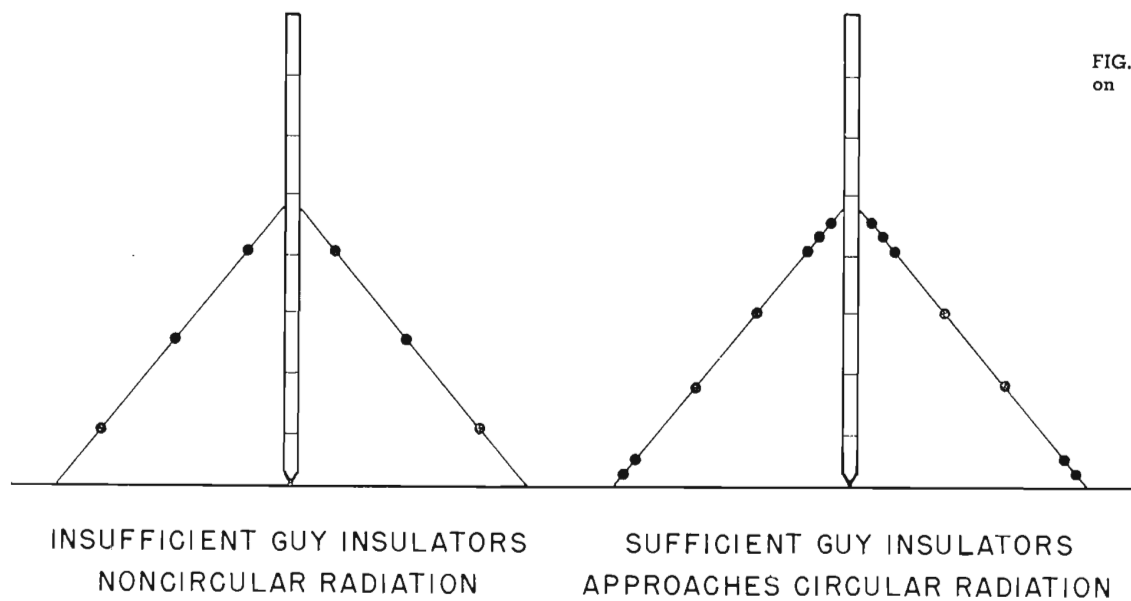

FIG. 7. Effect of number of guy insulators on radiation patterns of elements in a directional antenna.

II. Radiating Systems

It may be helpful to review a few of the factors that are involved in the radiating elements that go to make up an antenna system. On Fig. 6 we have shown the plan and elevation views of two typical towers. The tower shown on the left is a wide cross-section tower. If we look at the plan view, we see that there are 4 vertical members which are widely spaced at the base. Our studies indicate that, when such a tower is used in an antenna system, the currents in each of the legs are not necessarily equal and even vary in phase. This means that the wide cross-section

tower goes to make up four radiating elements instead of one radiating element. On the right-hand side of this figure will be seen a narrow cross-section tower. Our studies indicate that, in a narrow cross-section tower, the current tends to divide more evenly between the vertical elements and the current in each element is more nearly in phase with that in the other elements. This means that the narrow cross-section tower then more nearly approaches the single radiating element. This is quite desirable since theoretical designs are usually based on the assumption that the radiating element consist of a thin wire.

Fig. 7 shows two guyed vertical radiators. The figure on the left shows a guyed radiator with a limited number of insulators. Experience indicates that the pattern from the radiator is not circular when insufficient guy insulators are used. In this connection, it is well to note that it is just as desirable, if not more so, to have sufficient guy insulators at the point of connection to the ground as it is at the point of connection to the tower. The figure on the right shows a guyed radiator with what might be considered sufficient guy insulators. The pattern becomes circular where a sufficient number of guy insulators are used.

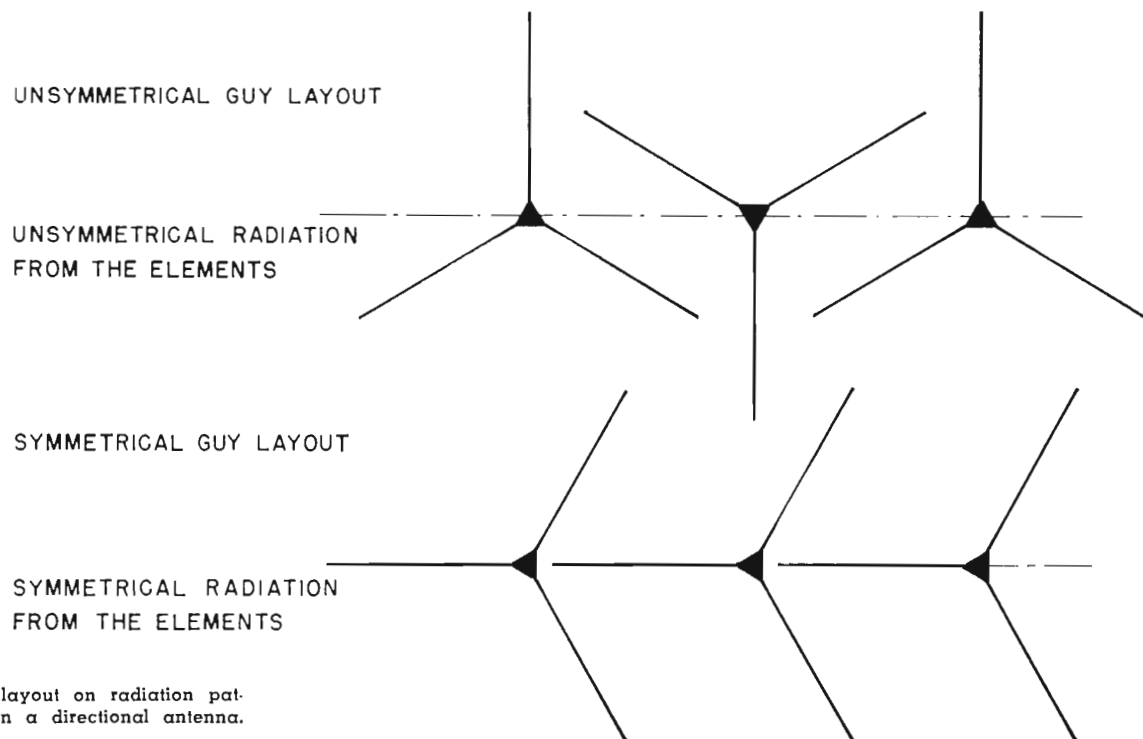

FIG. 8. Effect of guy layout on radiation patterns of the elements in a directional antenna.

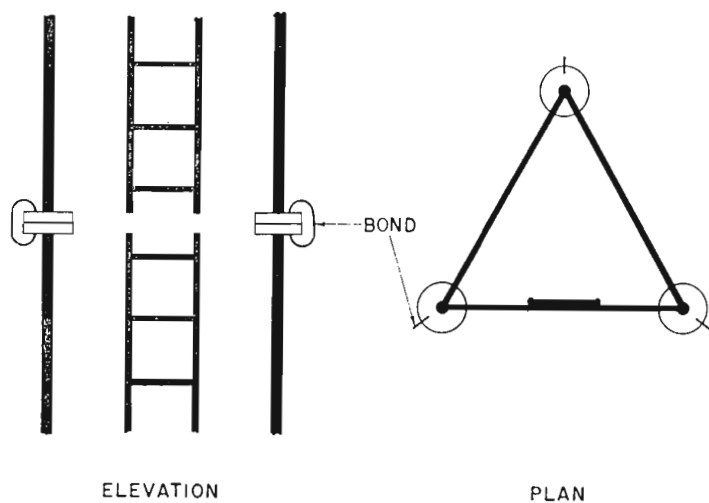

FIG. 9. Method of bonding tower sections to insure equal currents in all three legs.

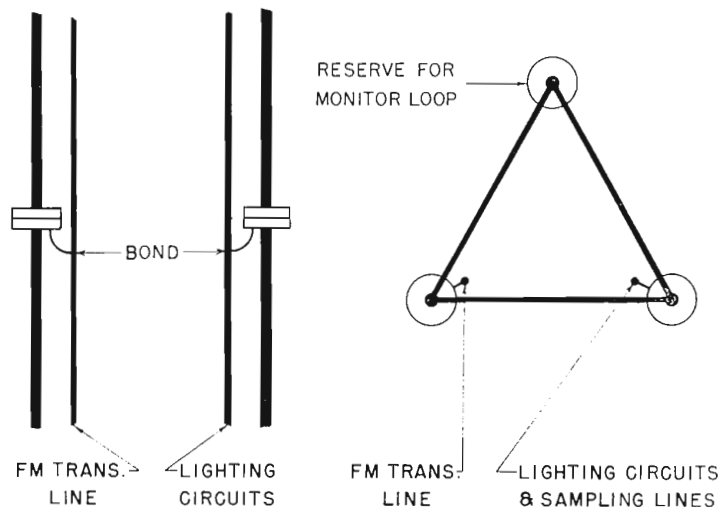

FIG. 10. Method of bonding transmission lines and lighting circuits to lower legs.

Fig. 8 shows two possible guy layouts for a 3-element directional antenna system. The upper layout shows an unsymmetrical guy layout. An unsymmetrical guy layout may cause considerable difficulty where the individual radiators do not have circular patterns. The lower layout shows a symmetrical guy layout. It is desirable that a symmetrical guy layout be used so that any distortions from the radiating elements will be symmetrical distortions.

Fig. 9 shows a portion of a guyed radiator. On this figure we have indicated that it is desirable that each section of a tower

be bonded to the next section. Such bonding will assure current flowing in each of the legs and tend to cause the currents to divide evenly. This figure also shows a ladder. We feel that ladders should be sectionalized so as to carry minimum current. If it is not possible to sectionalize the ladder as shown, it is then desirable to be certain that the ladder is securely bonded throughout the tower.

Fig. 10 shows a section of a guyed radiator which includes an FM transmission line and the usual lighting circuits. Since any conductor in a tower becomes a part

of the tower and tends to carry a portion of the current, it is quite desirable that these conductors be carefully bonded to the tower throughout its length. We suggest that transmission lines and lighting circuits be bonded to the tower at intervals of approximately 20 feet. This figure also indicates that the transmission lines and lighting circuits should be located within the towers in such a way as to leave one leg of the tower entirely free of influencing factors. This leg is reserved for the monitor loop which feeds the current and phase monitor to be discussed later.

III. Ground Systems

Fig. 11 shows the typical ground system used for a non-directional antenna system. Such a ground system usually consists of 240 radials, each approximately 10° to 15° long and buried 2" to 4" and arranged so that the alternate 120 radials extend to approximately 90° and are buried 6" to 8" along the extension. Fig. 12 shows the typical ground system used for a direc-

tional antenna. The general scheme is the same as used for the non-directional antenna except that a copper strap is installed between the towers and another copper strap is installed midway between the two antenna systems and used as a common bonding strap to terminate all of the radials that would otherwise overlap.

Fig. 13 shows a ground system layout that can be used quite successfully where

it is necessary to have a road or a creek between the towers. It should be noted that the ground system will be quite similar to the typical ground system, that all of the radials on one side of the creek or road are bonded to a copper strap, and that all of the radials on the other side of the creek or road are bonded to a second copper strap. The two ground systems are then connected with straps that go either under the road or over the creek.

Fig. 14. shows a ground system layout that can be used quite successfully where it is necessary to give special consideration to conditions where tides, floods, snowfall, or vegetation would affect the stability of the directional array. We have found that the use of a raised ground screen about each of the towers greatly improves the stability in such cases. The ground screen can be raised just above the level of the factor that is causing the change; however, after having installed several such systems, we suggest that the ground screen be raised at least 7 feet or 8 feet. A person can then walk under the ground screen and thus make the installation and maintenance much simpler than if the ground screen is near the ground.

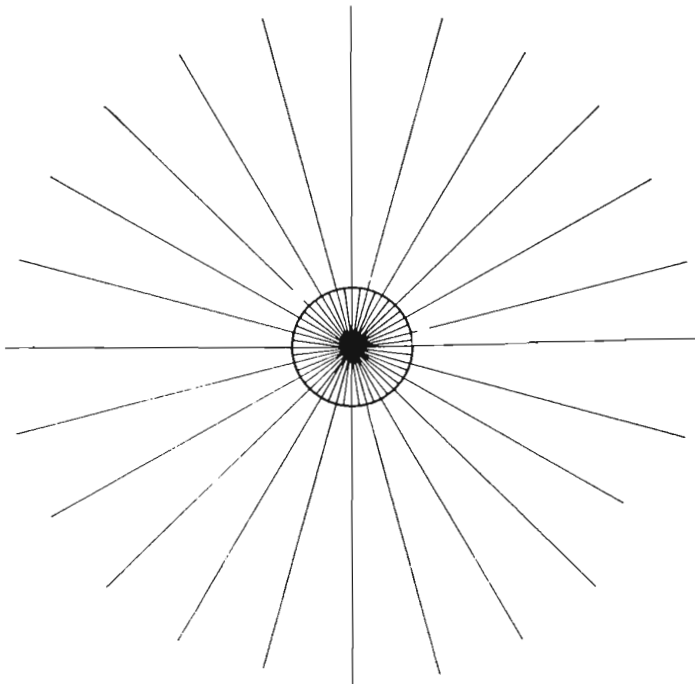

FIG. 11 (left). Typical ground system layout for a single-element non-directional antenna.

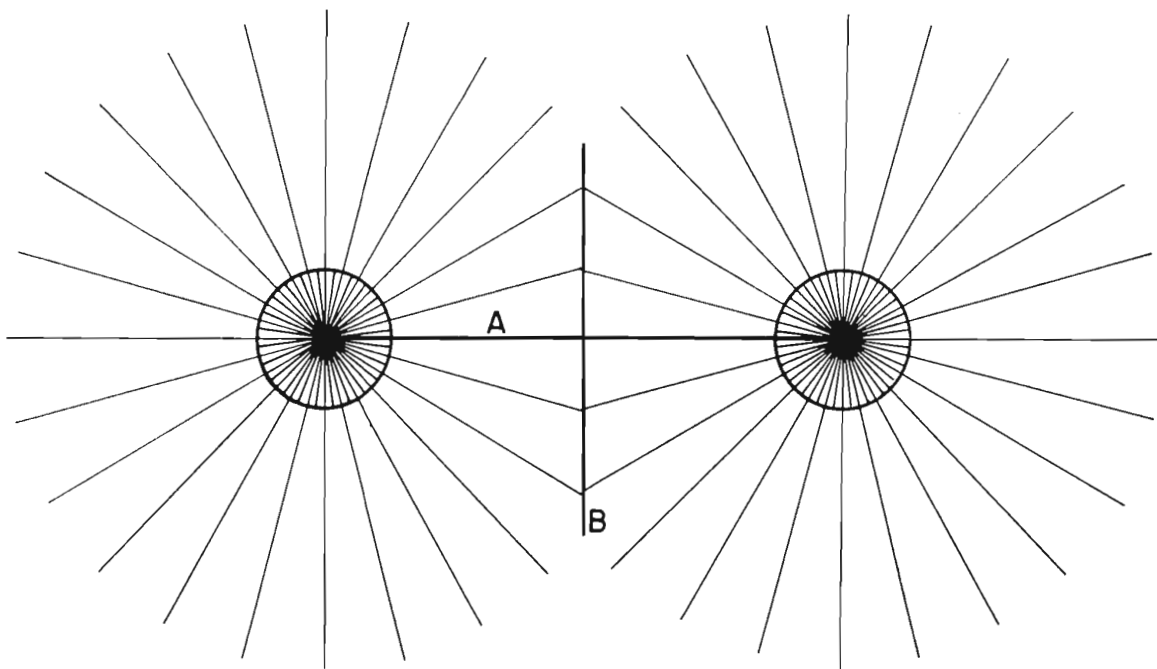
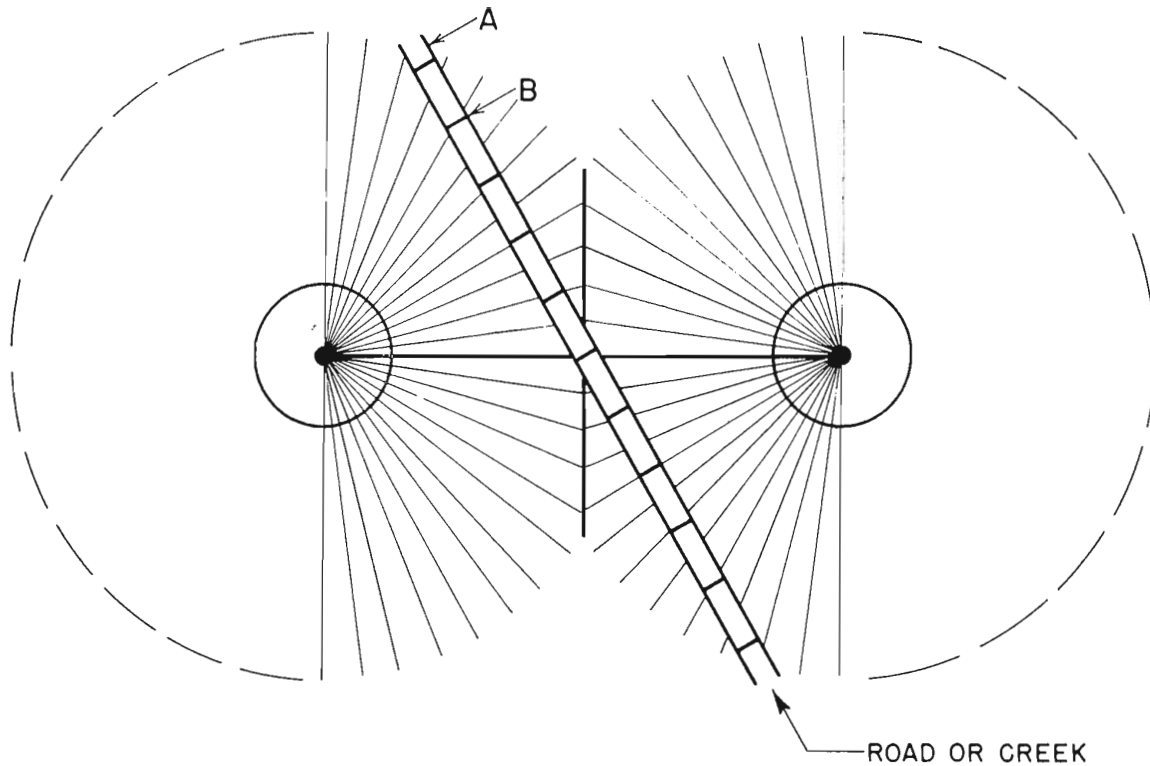
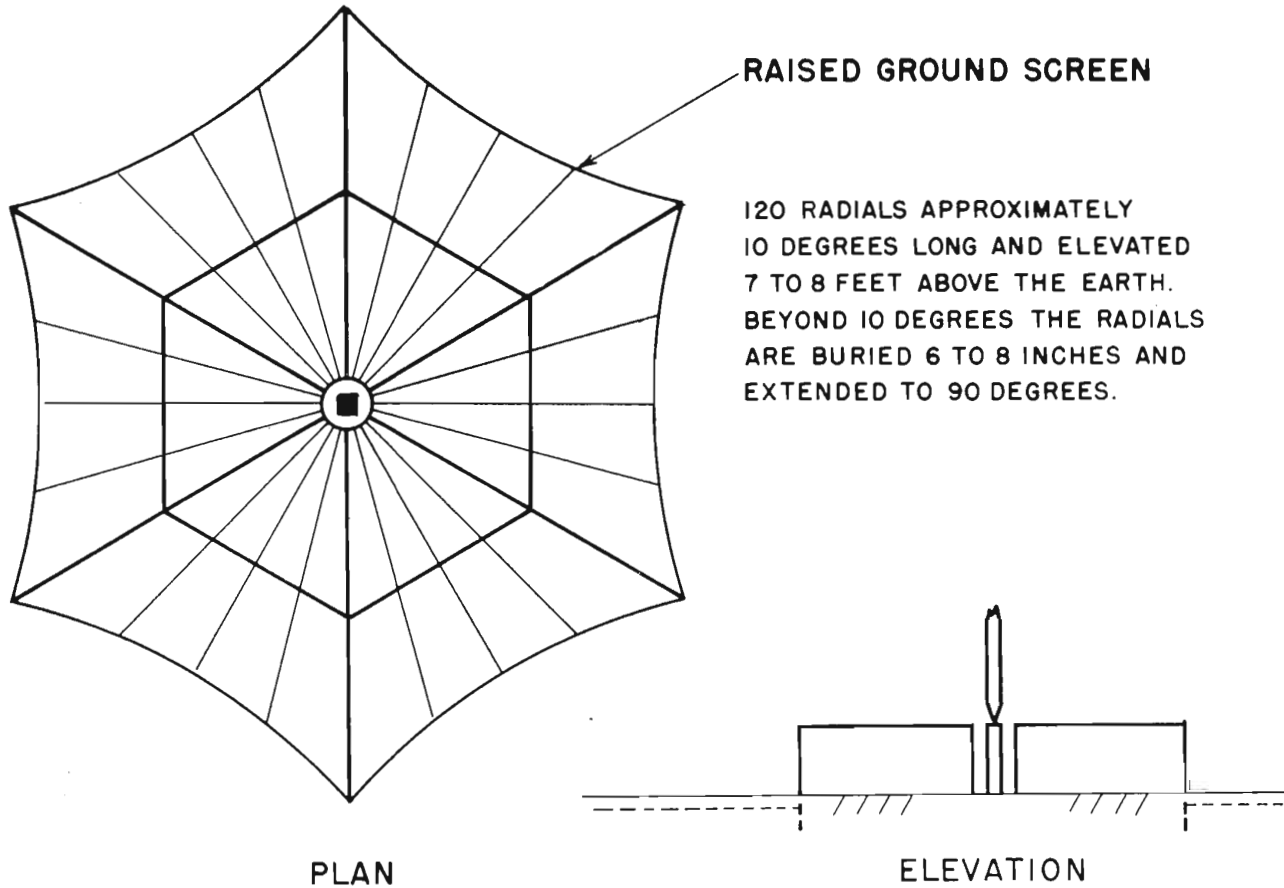

FIG. 12. Typical ground system layout for a 2-element directional antenna. A copper strap A is run between towers and another strap B is placed midway between the towers and used as a terminal for the radials which would otherwise overlap.



- A — STRAPS ALONG ROAD OR CREEK BONDED TO RADIAL WIRES
- B — BONDS UNDER THE ROAD OR OVER THE CREEK CONNECTING THE STRAPS

FIG. 13. A special ground system layout which may be used where a road or creek intersects the antenna location.



RAISED GROUND SCREEN

120 RADIALS APPROXIMATELY
10 DEGREES LONG AND ELEVATED
7 TO 8 FEET ABOVE THE EARTH.
BEYOND 10 DEGREES THE RADIALS
ARE BURIED 6 TO 8 INCHES AND
EXTENDED TO 90 DEGREES.

FIG. 14. A special ground system which is recommended to obtain improved stability where tides or floods might effect the system's characteristics.

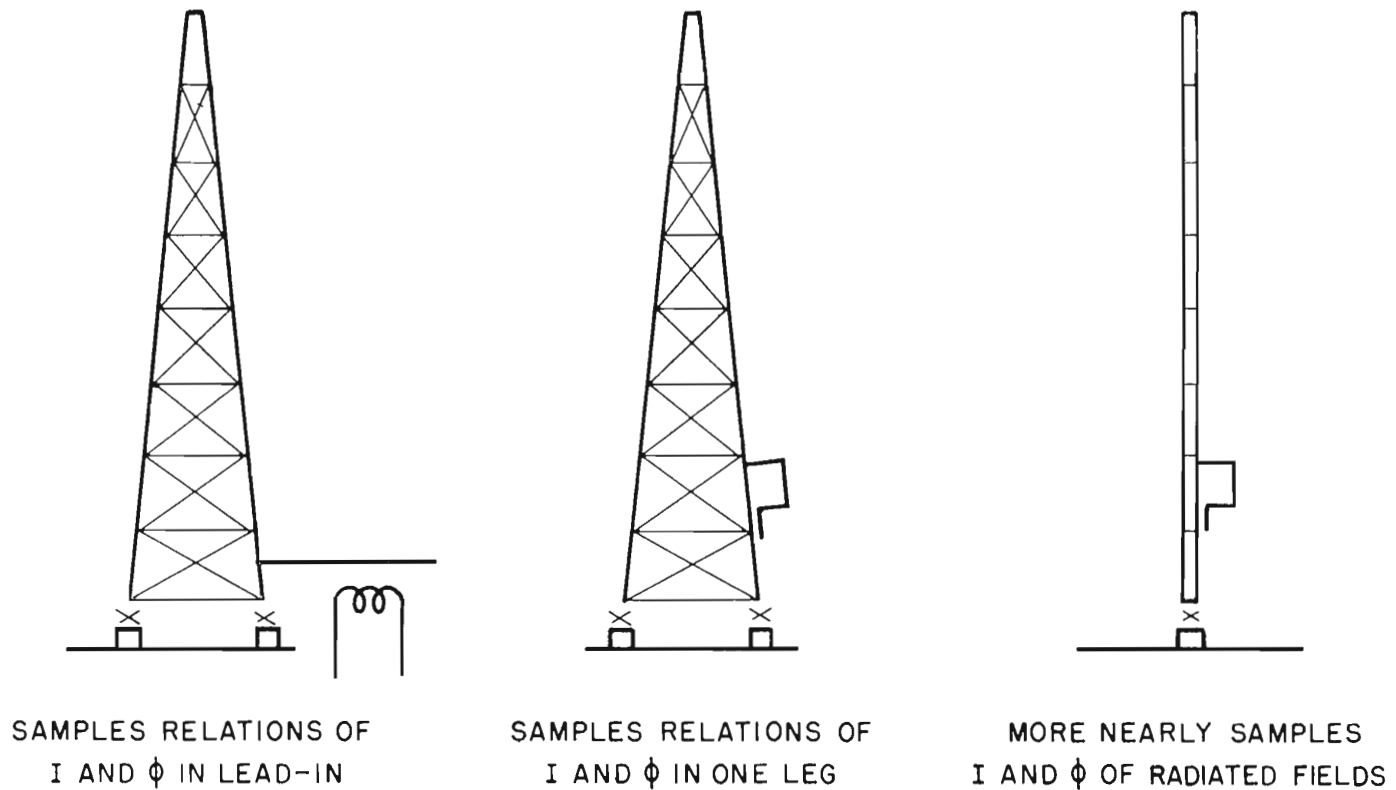

FIG. 15. Effect of sampling coil placement on the current picked up in the coil.

IV. Monitoring Systems

A directional antenna requires radiating elements and a good and stable ground system. In order to establish the directional antenna pattern, it is necessary to establish the proper relations between the fields radiated by the elements. It is necessary to sample the radiated fields, transmit the samples to a central point, and then compare the magnitude and the phase of the samples. Fig. 15 shows a typical antenna sampling system. The figure on the left shows a system that provides only a sample of the current in the lead-in. Such an arrangement is satisfactory for non-critical antenna systems but is not recommended for the more critical antenna systems. The figure in the center shows a means of sampling the field being radiated from a single leg of a wide cross-section tower. Such an arrangement provides sampling of the field being radiated by the one leg but does not necessarily provide accurate information regarding the magnitude and phase of the field being radiated by the tower. The figure on the right shows a monitoring system that provides a good sample of the radiated field.

Fig. 16 shows a portion of a typical antenna sampling system. Here we have a loop that is made up of a single turn which, in turn, feeds the sampling line.

It should be noted that the top of the loop is bonded to the tower, that the bottom of the loop is connected to the center conductor of the sampling line, and that the outer conductor of the sampling line is bonded to the tower. Fig. 17 shows a typical antenna monitoring system. The loops feed the samples through concentric sampling lines to the current and phase monitor. All concentric sampling lines should be of equal length. For best stability, the characteristic impedance of the concentric sampling line should be the same throughout.

Fig. 18 shows a typical antenna monitoring system. In order for the monitor to indicate properly the magnitude and phase relations between the samples, it is desirable that the input impedances Z_1 and Z_2 of the phase monitor be adjusted to the characteristic impedance of the sampling line. When this has been done, the input impedances Z_3 and Z_4 of the sampling lines will be identical and, in turn, provide identical loads for each of the monitor loops. If the monitor loops have been carefully installed, and careful adjustments have been made so that Z_1 , Z_2 , Z_3 , Z_4 , and Z_0 are equal, we can then expect the current and phase monitor to indicate the relative magnitudes and relative phases of the radiated fields.

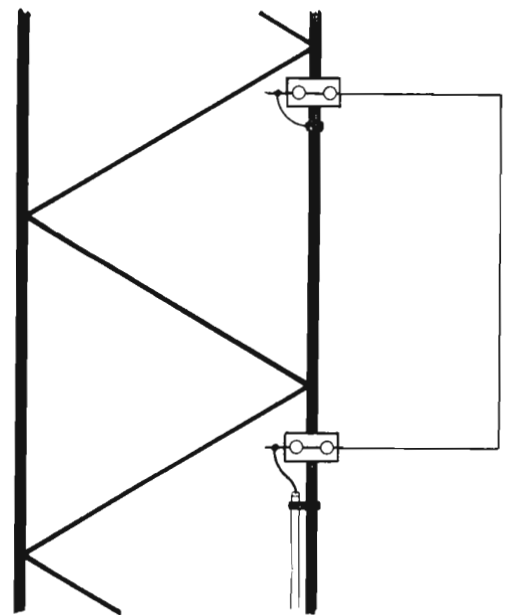
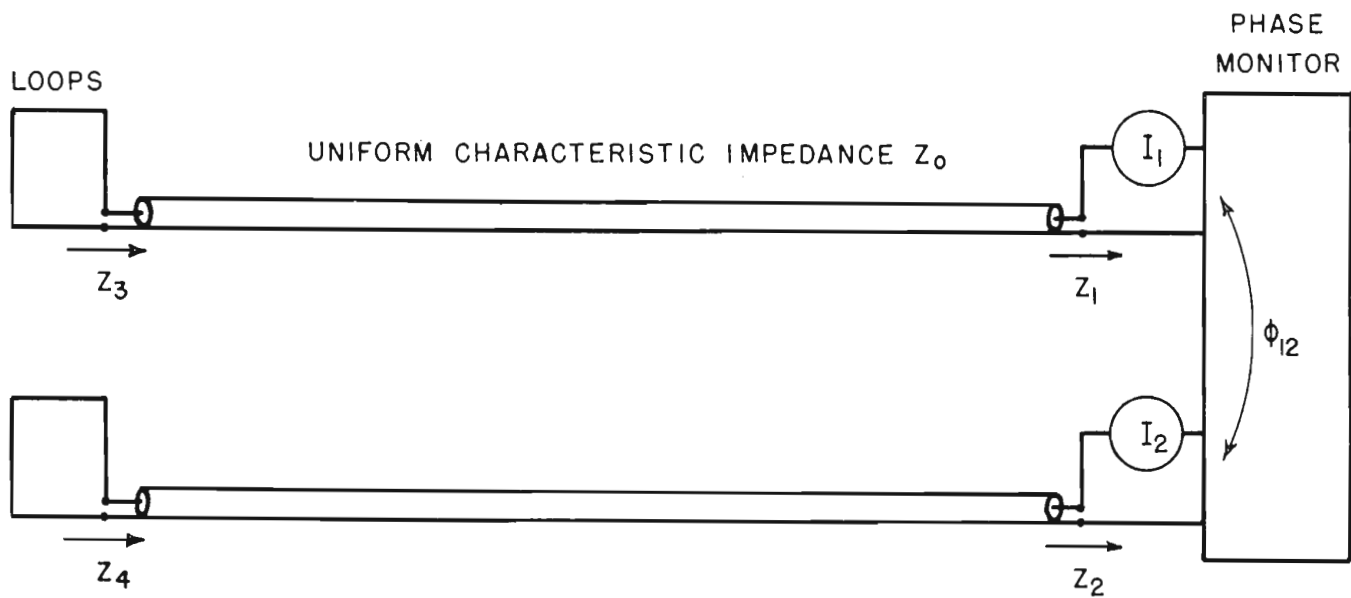
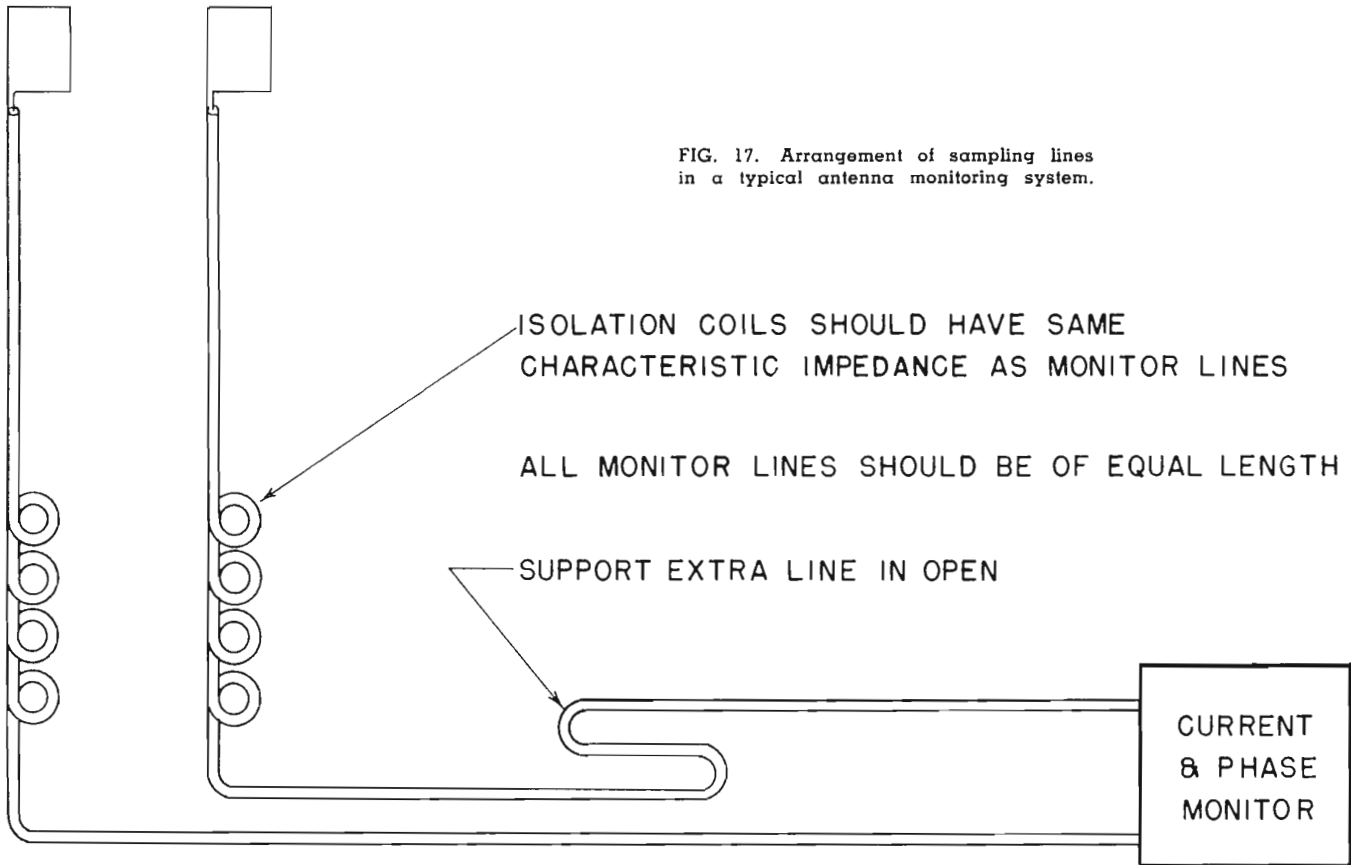

FIG. 16. Diagram showing detail of sampling coil mounted on one leg of tower. All coils should be identical, mounted at the same height and in the same relationship to the tower proper.

FIG. 17. Arrangement of sampling lines in a typical antenna monitoring system.



DESIRABLE CONDITION $Z_1 = Z_2 = Z_3 = Z_4 = Z_0$
 RELATIVE MAGNITUDE OF RADIATED FIELDS = I_1/I_2
 RELATIVE PHASE OF RADIATED FIELDS = ϕ_{12}

FIG. 18. Impedance matching in a typical antenna monitoring system.

PROMOTIONS FOR RCA SALES AND PRODUCT MANAGERS

In a sweeping series of changes the Engineering Products Department of RCA last month upped to positions of greater responsibility a group of sales and product managers, many of whom are well-known to broadcasters through their long service with RCA's broadcast equipment sales group.

T. A. (Ted) Smith was named Assistant General Manager, and placed in charge of the Engineering Products Department during the absence of W. W. (Wally) Watts, who was called to Washington on the first of the year to serve as special assistant to the Defense Production Administrator.

A. R. Hopkins, formerly manager of the Broadcast and Communications Sales Section, was appointed General Sales Manager of the department, and now directs all activities of the Sales Division. C. M. (Buck) Lewis, previously Broadcast Field Sales Manager, is now manager of the Broadcast and Communications Sales Section. He will be assisted by E. C. (Ed) Tracy as Broadcast Equipment Sales Manager, and Dana Pratt as Communications Equipment Sales Manager.

Simultaneously with these changes a new group, the Product Administration Division, was established to parallel the Sales Division. This new division will have the responsibility of planning and coordinating the engineering and production of equipment. Barton Kruezer, formerly manager of the Theatre, Sound and Visual Sales Section, was appointed General Product Manager and will direct the division. Merrill Trainer, formerly Studio Equipment Manager, has been promoted Broadcast Equipment Product Manager.



T. A. (TED) SMITH
Assistant General Manager, Engineering Products Department



A. R. (HOPPY) HOPKINS
General Sales Manager, Engineering Products Department



B. (BARTON) KREUZER
General Product Manager, Engineering Products Department



C. M. (BUCK) LEWIS
Manager, Broadcast and Communications Equipment Sales

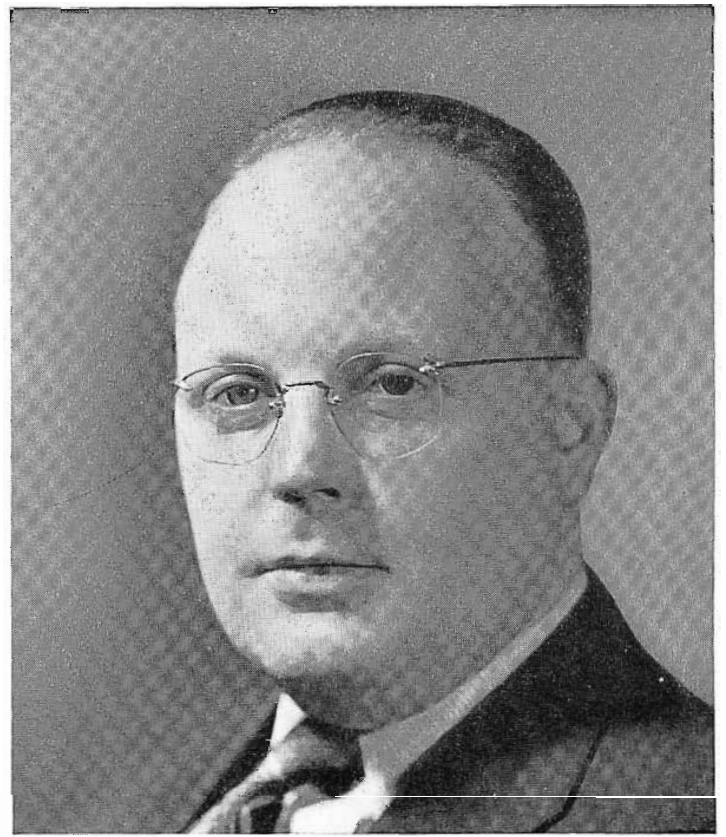

M. A. (MERRILL) TRAINER
Product Manager, Broadcast Equipment



E. C. (ED) TRACY
Manager, Broadcast Equipment Sales



D. (DANA) PRATT
Manager, Communications Equipment Sales

RCA BROADCAST SALES REPRESENTATIVES



◀ **A. (Al) Josephsen**
36 WEST 49TH STREET
NEW YORK 20, NEW YORK
Phone: Circle 6-4030

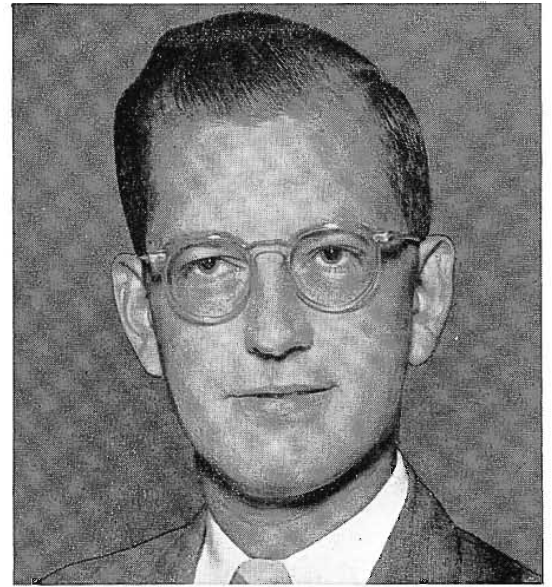

L. W. (Len) Haeseler ▶
FRONT AND COOPER STREETS
CAMDEN, N. J.
Phone: Woodlawn 3-8000



▶ **F. D. Meadows**
(Dan)
666 N. LAKE SHORE DR.
CHICAGO 11, ILLINOIS
Phone: Delaware 7-0700

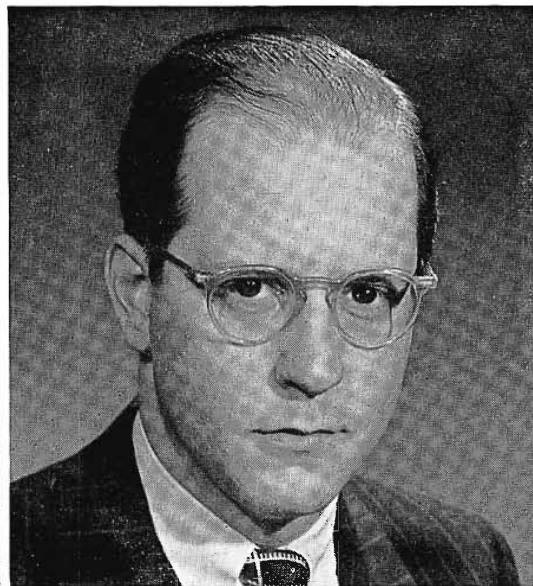

◀ **D. S. Newborg**
(Dave)
718 KEITH BUILDING
CLEVELAND 15, OHIO
Phone: Cherry 1-3450



J. E. (Ed) Hill, Jr. ▶
36 WEST 49TH STREET
NEW YORK 20, NEW YORK
Phone: Circle 6-4030



◀ **J. H. (Jim) Keachie**
718 KEITH BUILDING
CLEVELAND 15, OHIO
Phone: Cherry 1-3450

RCA BROADCAST SALES REPRESENTATIVES



J. L. Nickels
(Nick)
 666 N. LAKE SHORE DR.
 CHICAGO 11, ILLINOIS
 Phone: Delaware 7-0700



J. F. Palmquist
(John)
 1907-11 McKINNEY AVE.
 DALLAS 1, TEXAS
 Phone: Riverside 1371,
 1372, 1373



J. W. (John) Hillegas
 522-533 FORSYTH BUILDING
 ATLANTA 3, GEORGIA
 Phone: Walnut 5946



W. B. (Walt) Varnum
 221 WEST 18TH STREET
 KANSAS CITY 8, MISSOURI
 Phone: Victor 6410



W. D. Wenger
(Wiley)
 1907-11 McKINNEY AVE.
 DALLAS 1, TEXAS
 Phone: Riverside 1371,
 1372, 1373



P. G. Walters
("P.G.")
 522-533 FORSYTH BLDG.
 ATLANTA 3, GEORGIA
 Phone: Walnut 5946

RCA BROADCAST SALES REPRESENTATIVES



◀ **E. (Jack) Frost**
1560 NORTH VINE STREET
HOLLYWOOD 28, CALIFORNIA
Phone: Hollywood 9-2154



J. P. (John) Riley
1355 MARKET STREET
SAN FRANCISCO 3, CALIFORNIA ▶
Phone: Hemlock 1-8300

NEW BOOK ON TV AND RADIO JUST RELEASED

AUTHORED BY ORRIN E. DUNLAP, JR.

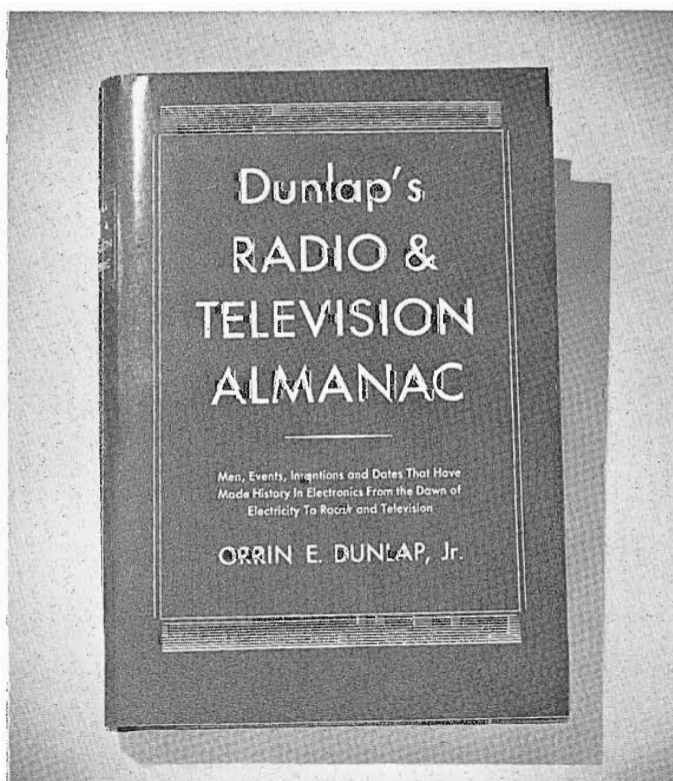

Mr. Dunlap's almanac of facts, dates and people covering the history of radio and television represents nearly thirty years of intensive "fact finding" and study. The chronological record begins with the first rudimentary discoveries in electronics in the seventeenth century, and carries right up to the year 1950. It covers not only technical developments but the history-making events in such fields as international affairs, national politics, sports, aviation, the arts, for which radio and television have served as prime channels of public information. The almanac includes also a record of the officials, past and present, of the various radio and television trade associations, institutes and commissions. A detailed index of names and subjects provides complete cross reference to the chronological history.

The almanac is illustrated with over sixty "then and now" photographs dramatizing the progress of radio and television.

For every broadcasting company, newspaper office, radio station and advertising agency this will be a handy reference book. (Price \$4.00.) Write to Harper & Brothers, Publishers, New York City, N. Y.

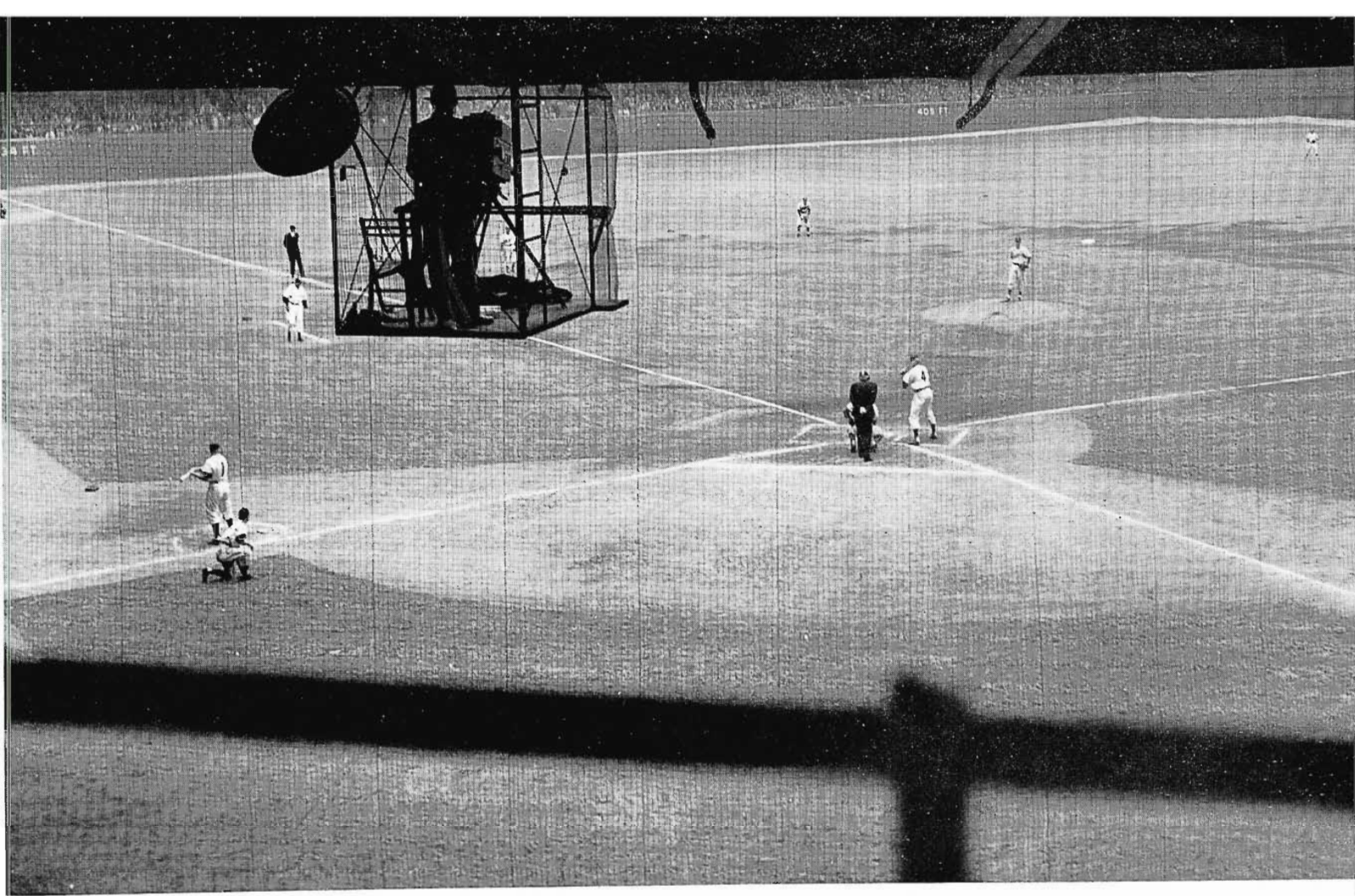

FIG. 1. WPTZ's No. 1 Camera position at Shibe Park, Philadelphia.

MORE BASEBALL TELEVISION

A REPORT ON WPTZ'S COVERAGE OF THE 1950 WORLD SERIES

by
JOHN P. TAYLOR
 Engineering Products Department

Several previous articles in BROADCAST NEWS* have covered the subject of baseball TV rather thoroughly—especially those aspects of it which are primarily the engineer's concern (i.e., camera positions, lens choices, switching, etc.). In fact, after our last big roundup story (BROADCAST NEWS, No. 56, September 1949) it didn't seem likely that we would ever have anything more to say on the subject.

However, just a year later, something totally unexpected happened—the Phillies won a pennant. That meant a World Series, or part of it anyway, practically in our backyard—and with our favorite remote

* "Camera Placement and Switching for Baseball Telecasting," by John P. Taylor, BROADCAST NEWS, Vol. No. 46, September 1947.

"Baseball Television," by John P. Taylor, BROADCAST NEWS, Vol. No. 56, September 1949.

"WPIX Baseball," BROADCAST NEWS, Vol. No. 56, September 1949.

camera crew (WPTZ's) doing the pickup. When we learned that WPTZ (which has been notable for its success with a two-camera operation) was going to expand to five cameras for the series, we immediately decided that here was an opportunity to complete some unfinished research (sic).

Background of the Camera Question

One question which our earlier investigation of baseball TV techniques had not completely answered was that of the best number of cameras to use. We had found that some stations were using two cameras with pretty good results. Others were using three or four cameras. Exactly what did the extra cameras contribute? Were they really worth the very considerable extra operating cost? We asked a lot of station people these questions, but were never really satisfied with the answers. We also tried watching different setups ourselves—without coming to a definite conclusion. The trouble was that we could never find a direct comparison which was free from all other influencing factors (such as lim-

itations on camera positions which in many cases made a third camera a necessity).

Thus, when WPTZ (whose two-camera baseball telecasts were very familiar to us) announced they would use five cameras for the 1950 Series, we felt that at long last our opportunity to make a good direct comparison had arrived. It wasn't just that here was a two-camera crew suddenly gone five-camera crazy. In the hands of engineers and producers of limited experience that would have been worse than nothing. But WPTZ's baseball crew is the most experienced in the business. Since 1947 they have originated the home games of both the Phillies and the Athletics. WPTZ's producer-director team of Pres Stover and Cal Jones has more than 500 big league games to its credit. Engineer John Roth has supervised the technical installations for the same number of games. It's a record that is unequalled. If there ever were men who could get everything possible out of cameras—whether it be two or five—here were the men to do it.

WPTZ's "Regular Season" Camera Setup

WPTZ, as we noted before, has been using two cameras for its Shibe Park pickups during the regular season. These two cameras are in what we have always considered almost ideal positions. The No. 1 Camera is located in a special cage which is suspended *below* the upper tier at a point which is behind homeplate but just enough to the right of the pitcher-batter line to give a little angle (and perspective) to the camera view. This camera is used for the "standard" or "working" shot. A 5-inch lens is used when there are no base-runners and a 3-inch when there is a man on. The location of this No. 1 Camera, and the two versions of the "working" shot used by WPTZ are shown in the illustrations on the opposite page. WPTZ's regular No. 2 Camera is located in the press box. It is almost directly over No. 1 but is much higher—being something like 65 feet above ground as compared to No. 1's approximately 20 feet. During the season this camera was used for closeups between pitches, for outfield action, for "relief" shots, and for producing commercials from charts. Because of the long experience of the WPTZ crew, and their ability to anticipate the action (and hence the likely switching sequences) this two-camera setup performed remarkably well.

WPTZ's Camera Setup for the Series

Ray Bowley, Chief Engineer of WPTZ, and his crew began setting up special facilities at Shibe Park some two weeks before the opening of the World Series. This early start not only enabled them to carefully check out all of their equipment setups, but also made it possible to try out several alternative locations for the additional cameras which had been decided upon.

Since WPTZ's regular No. 1 and No. 2 Camera positions already provided such good coverage of homeplate, it was logical to use the additional cameras for coverage of other areas. No. 3 Camera, therefore, was placed "behind third"; No. 4 Camera, "behind first"; and No. 5 Camera, in the press box alongside the regular No. 2 Camera.

During the two weeks before the Series the precise locations of No. 3 and No. 4 were changed from day to day in order to determine the best possible positions. In particular, several different heights were tried for the No. 4 Camera—the one "behind first". Positions tried included both high and low spots. In our opinion each has some advantages, and some disadvantages.

The low camera position adds a new angle in that it "looks up" at the pitcher on the mound—and to a lesser degree at the batter. However, because the viewer cannot see the baseline pattern, he sometimes has trouble placing the action. This lack of perspective in the picture is aggravated by the great depth of focus of the TV camera which has the effect of making the left fielder seem no further from the camera than the second baseman.

The higher camera position makes it much easier for the viewer to orient himself and to place the action. From this position he can see the baselines—or at least enough of them to place the action. In addition, the "looking down" angle adds a certain amount of perspective to the scene which is also helpful. However, the extra height is usually gained at the expense of closeness to the field—so that the intimacy of the lower position is lost.

WPTZ's final choice was to place the No. 3 Camera high on a platform protruding from the upper tier seats; and the No. 4 Camera low, in a position corresponding to that of the boxes, practically at field level. No doubt the practicalities of the situation had something to do with the choice. In any event, it turned out to be a happy compromise since the two cameras, one low and one high, gave the director a nice choice of shots on infield plays.

The third added camera, No. 5, was placed in the press box adjacent to the regular No. 2 position. It was used for all commercials—thereby allowing No. 2 Camera to be used full time for action and "color" shots.

Pictures showing the locations of all five cameras—and typical "shots" made with each—are shown on the following pages. Although the number of the latter which we could include was necessarily limited, they should serve as an indication of what can be done from each position.

How Did It Work

Performance rather than theory is the final criterion of a camera setup. Millions of people saw the Series on TV, and it was obvious they liked the job which the cameras did. Even the critics liked it!

We agree—it was a beautiful job of camera work. However, the question we wanted to resolve was: are five cameras better than two—and, if so, how much?

We think that we can answer best by dividing into three classifications the ac-

tion which the cameras must pick up. These are:

- (1) The "main" action—which is pitcher throws, batter swings, catcher returns, or batter hits to infielder who throws to first. This probably accounts for eighty or ninety percent of the action in a typical game.
- (2) The "extra" action which occurs when the batter hits to the outfield.
- (3) The "color" shots of crowd, players, umpires, etc., between pitches and between innings.

Now let's consider each in turn. For the "main" action very little was added to WPTZ's pickup by the extra cameras. First because they could not "see" anything which the regular No. 1 and No. 2 couldn't "see". Second because on most infield action it is more comfortable to the viewer to follow the ball with one camera than to switch. During the two weeks test period before the Series began, WPTZ used, for a short time, a switching sequence in which the No. 4 Camera ("behind first") showed the pitcher throwing, followed by a quick switch to No. 1 to show the batter swinging. We didn't like it—and apparently they didn't either, for it was not used during the Series. In fact, the "main" action of the Series was carried almost entirely by the two regular cameras.

As for the "extra" action, this was largely covered by the regular No. 2 Camera from the Press Box. Cameras No. 3 and No. 4 were used occasionally, particularly on the return of the ball. However, so far as we could tell their only big advantage was in giving the director more leeway—and a better chance to catch unexpected incidents.

On the "color" action the story is different. Here the extra cameras were a big help. They "saw" things the regular cameras could not—such as the batters' facial expressions. They provided intimate close-ups, at first base especially. And, most important of all, they gave the director extra "eyes"—so that he could weave far more color into the pickup than is possible where his only cameras must "follow the ball" at all times.

Summary

Our summation is that (1) two cameras are enough for the essential action, additional cameras make it easier but not a whole lot better; (2) one or two extra cameras for "color" shots are a luxury—but a mighty nice one if you can afford it. The proof of these conclusions, we think, can be found in the pictures on the following pages.

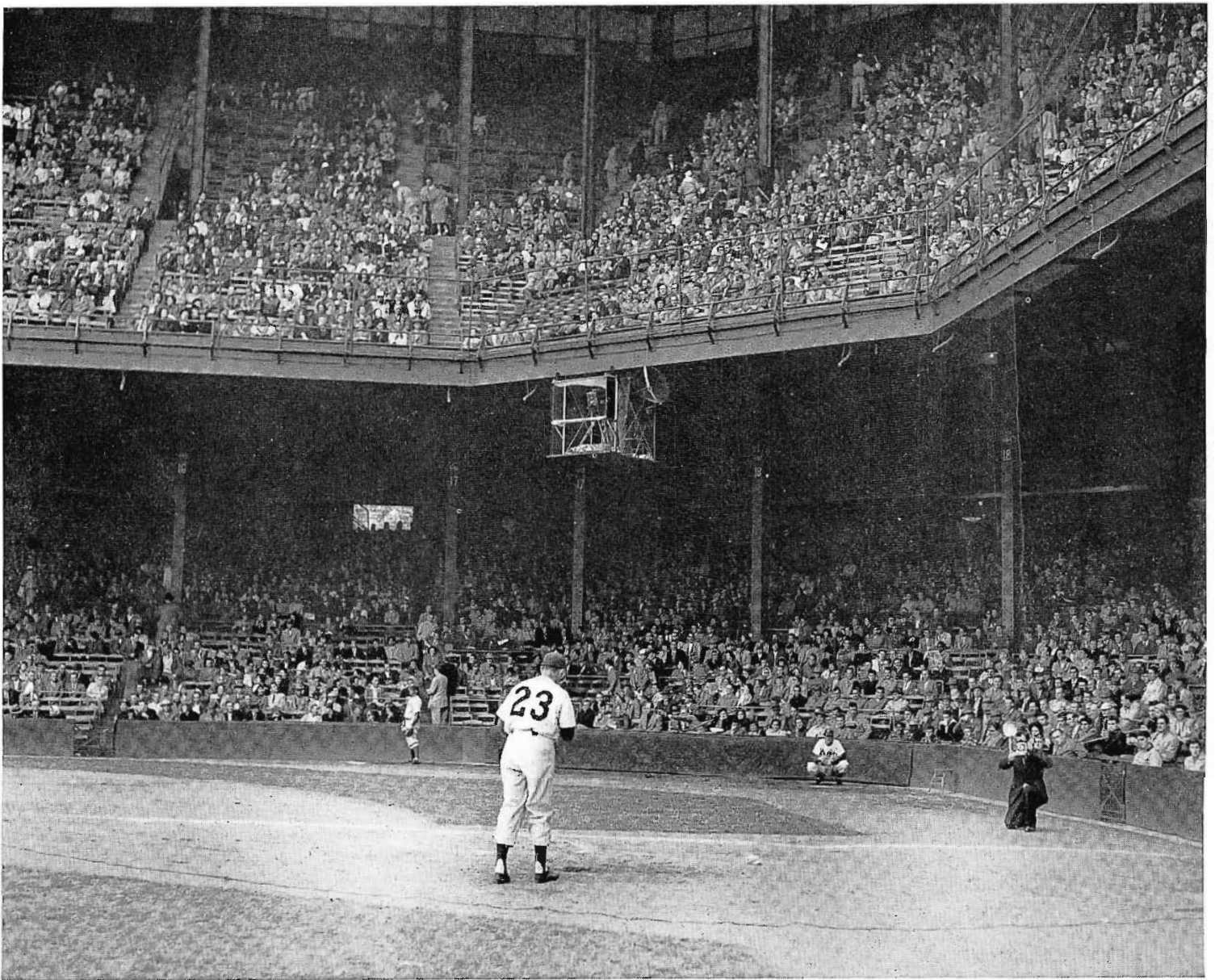

FIG. 2. Camera No. 1 in its cage behind homeplate. Position is about 20 feet high and approximately 70 feet from the plate.

CAMERA No. 1 - In Cage Suspended From Upper Tier

WPTZ's No. 1 Camera for the Series was located in the same spot it occupied during the regular season. This is a glass-fronted "cage" suspended from the second

tier almost directly behind homeplate. This camera was used exclusively for the "working" shot (i.e., pitcher throwing, batter swinging, etc.). On infield plays it was

used to show the infielder picking up the ball and throwing—after which a switch was made to one of the other cameras to show the play at first.



FIG. 3. WPTZ's "working" shot, made with a 5-inch lens on the No. 1 Camera, provided an ideal view of the pitcher-batter-catcher area.

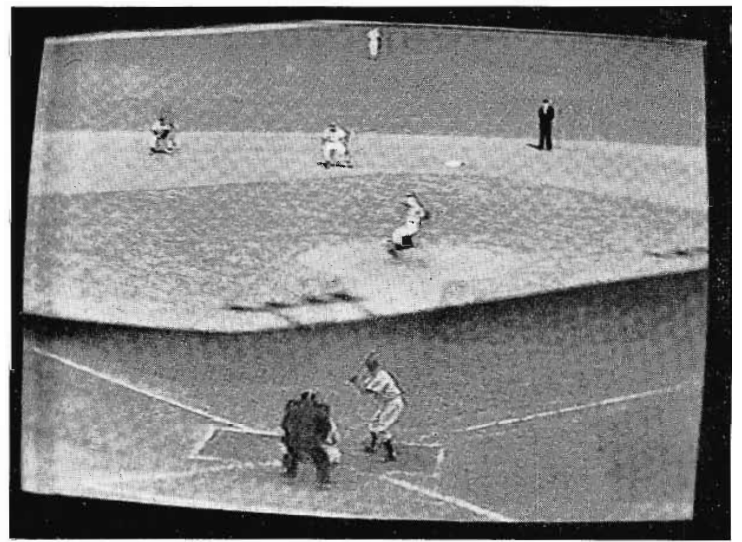

FIG. 4. With a man on base, WPTZ shifted to a 3-inch lens on No. 1 Camera so that the second base area was included in the view.

CAMERAS No. 2 and No. 5 - In Press Box, Behind Homeplate

Camera No. 2, like No. 1, was located for the Series exactly as for the regular season games. Its location in the press box behind and slightly to the right of homeplate commanded a view of every part of the field. Its height (approximately 65 feet) made it particularly effective for

wide angle "relief" shots between innings. During the regular season this No. 2 Camera was used by WPTZ to show closeups of batter and pitcher between pitches. However, during the Series Cameras No. 3 and No. 4 were used for these shots, so that No. 2 was used only for outfield shots

during actual play. In addition it was used for closeups of the Phillies' dugout (behind third base), the Phillies' bullpen (in far left field), "color" shots in the stands and on the field, the scoreboard, and, of course, the wide angle "relief" shots. A few typical shots from this camera are shown below and on the next page.

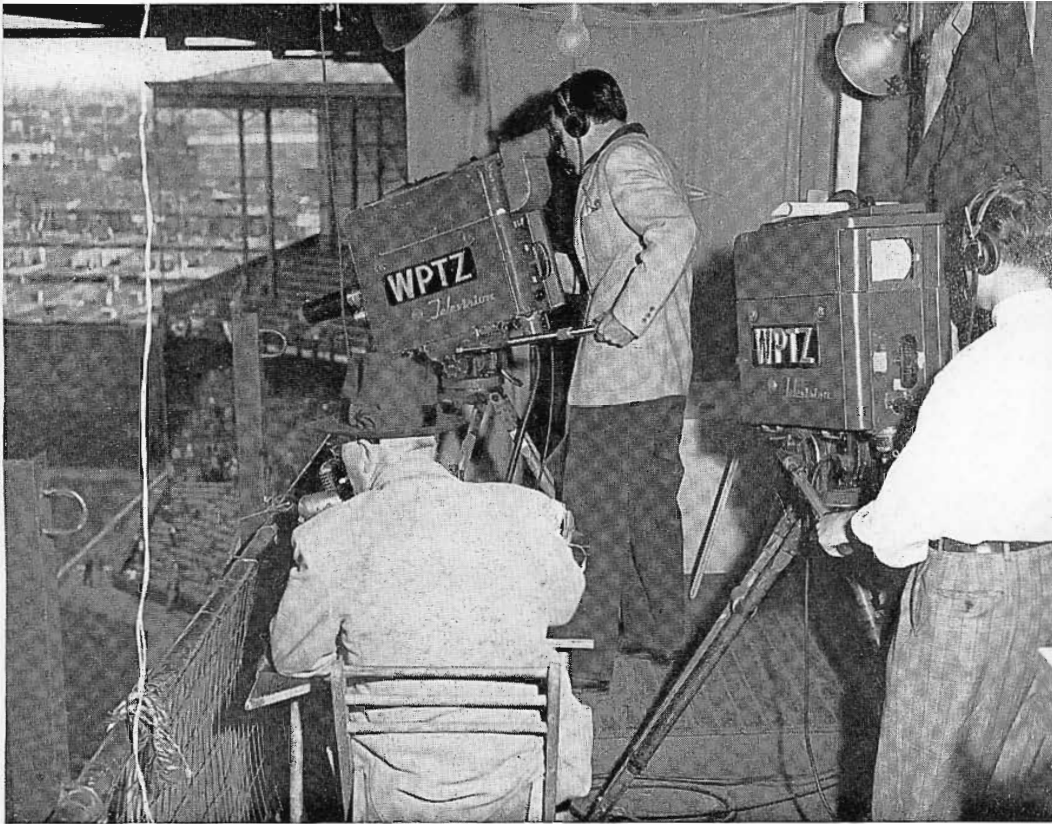

FIG. 5. WPTZ's No. 2 and No. 5 Cameras in the press box booth. The game announcer, with his back to us in the picture) watched a monitor built into the table in front of him. Commercial announcers sat at the far end of the booth. Chart easel is behind the No. 5 (righthand) camera.

During the regular season WPTZ also used Camera No. 2 for commercials (from artwork in chart form). However, this required considerable lens switching and camera panning so, for the series, an additional camera (designated No. 5) was placed alongside No. 2 and used exclusively for commercials. A booth was improvised by curtaining off a part of the press box as shown in the picture at the left. The table at the far end was used by the announcers for between inning commercials, interviews, etc. Artwork in the form of charts was also used for commercials and for general identification of the sponsor and telecasting networks. On occasions the picture from Camera No. 5 was superimposed on a shot of the playing field, as shown on the opposite page. Film commercials, used several times during each game, were originated in WPTZ's downtown studio.



FIG. 6. View of the "commercial" announcers as picked up by the No. 5 Camera. Tilting camera down brought product (on the table) into view.

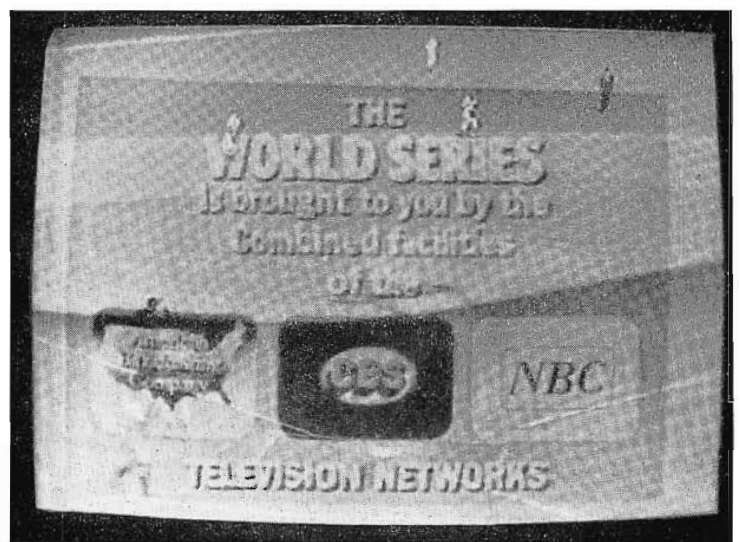

FIG. 7. For between-inning announcements this picture was obtained by combining a shot of the field with that of a chart on the easel.

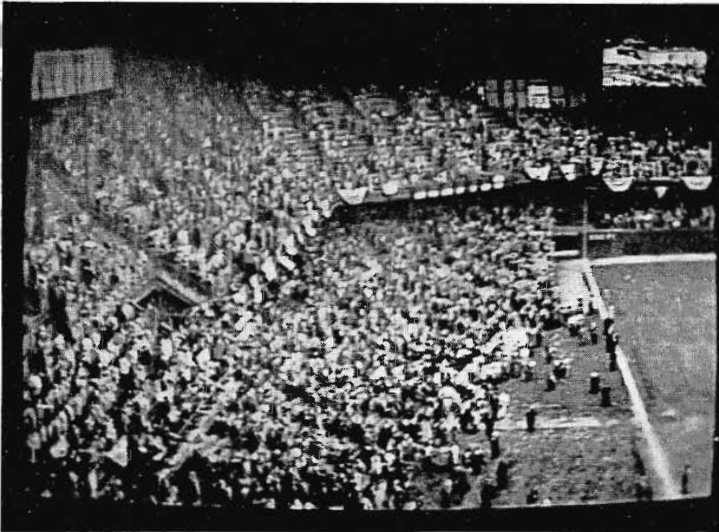

FIG. 8. Camera No. 2 was ideal for "panning" the crowd since it "looked into" both upper and lower tiers of seats.

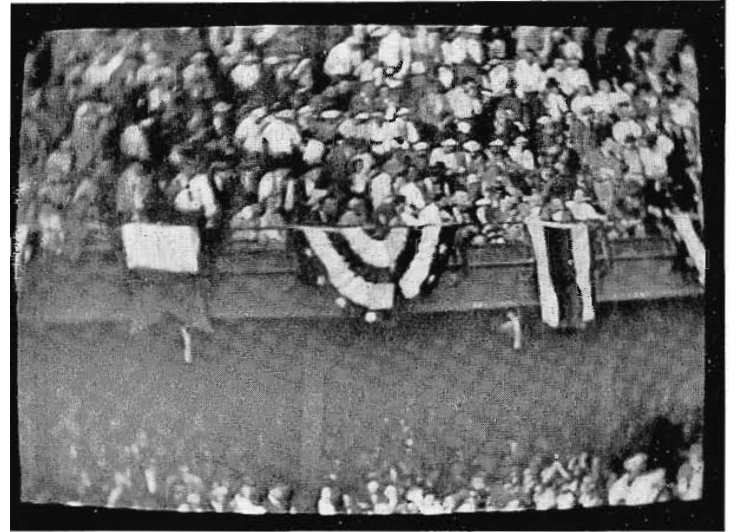

FIG. 9. With a 25-inch lens Camera No. 2 presented this closeup of the scramble for a ball hit into the upper left field stand.

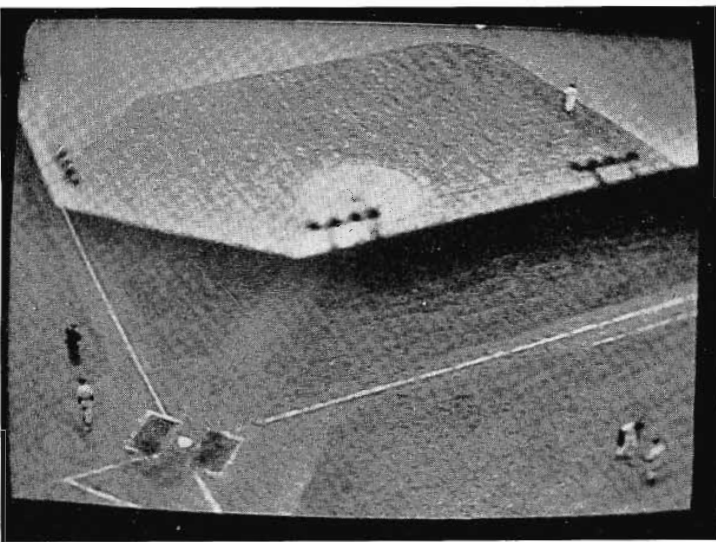

FIG. 10. Between inning "relief" shot made with a 2-inch lens on No. 2 Camera shows all of the infield.

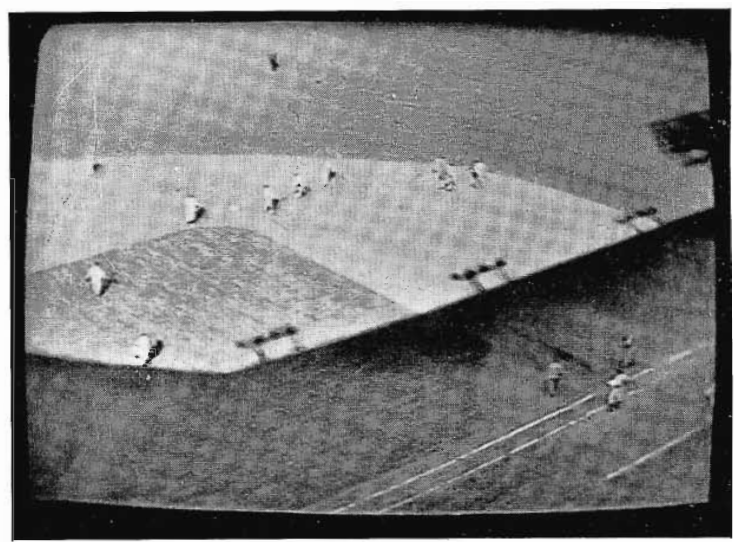

FIG. 11. Another version of the same shot. Note the shadows of the lights mounted above the roof of the stands.



FIG. 12. Closeup of entrance to hometeam (Phillies) dugout as picked up by No. 2 Camera using a 17-inch lens.



FIG. 13. The Phillies' bullpen in far left field (note 334-foot sign) as seen with No. 2's 17-inch lens.

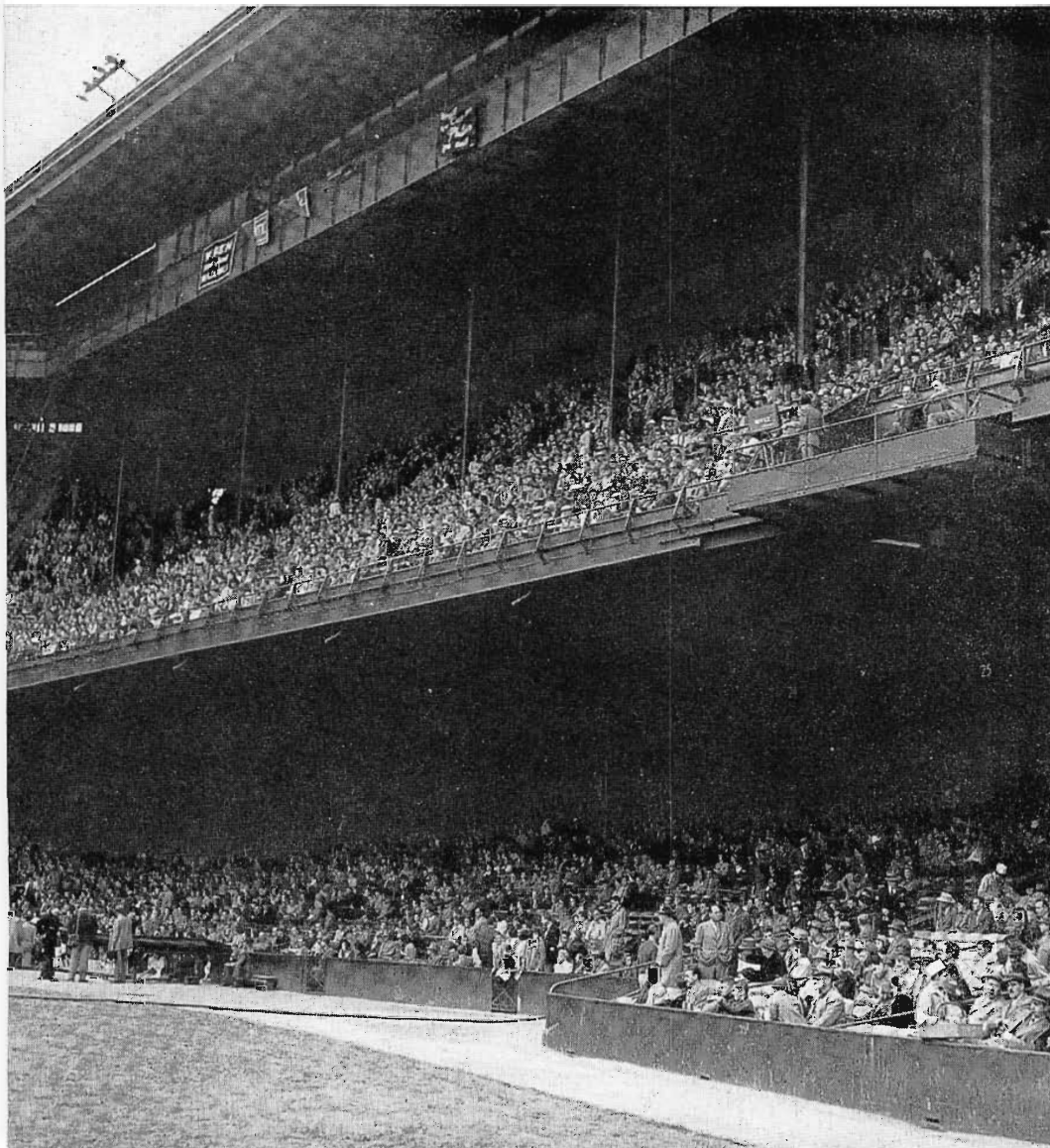
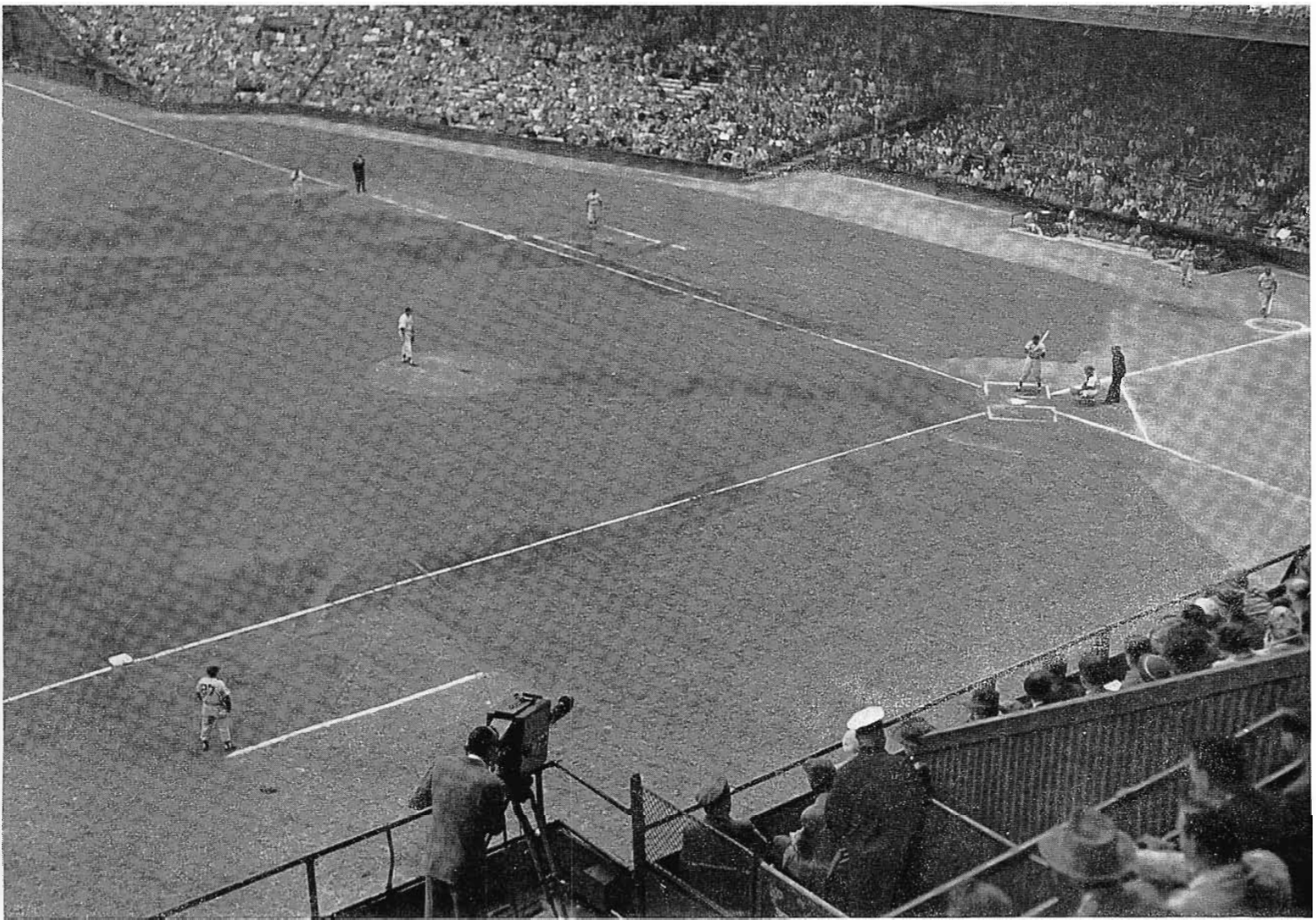

CAMERA No. 3 - High Above Third

One of the cameras which WPTZ added for the series was placed in a box projecting from the upper tier at a point just a little beyond third base. This position, shown in the illustration above and at the left, is about 35 feet high. It commands a beautiful view of the plate and of the visitors' (Yankees) dugout. In fact it soon became obvious that one of the best uses of this camera was in showing a batter leaving the dugout and walking up to take his position at the plate. In the case of left-handed batters it was also useful for showing the batter's stance as he faced the pitcher. In addition, of course, it was very good for closeups at second and third, for "pick offs" at first and for closeups in left field. Some of these shots are shown on the opposite page. A Zoomar lens was used on this camera all during the Series and it greatly increased the effectiveness of these scenes, especially when a rapid transition from wide-angle to closeup was called for.

FIGS. 14 and 15. Two views of WPTZ's No. 3 Camera. The relatively high position of this camera is shown by the view at the left.



FIG. 16. With its Zoomar lens the No. 3 Camera could show this relatively "long" shot of the batter, catcher and umpire.



FIG. 17. Or he could "zoom" in to show this closeup in which the batters' facial expressions were visible.

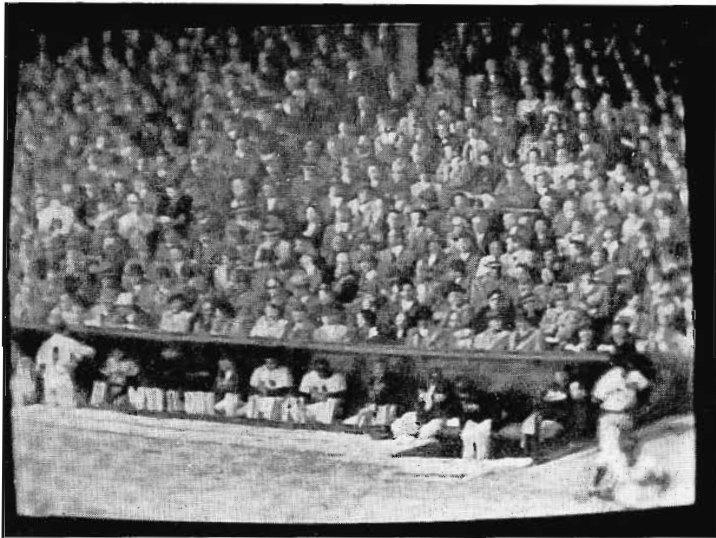

FIG. 18. The director could choose this shot of the length of the visiting team (Yankees) bench.

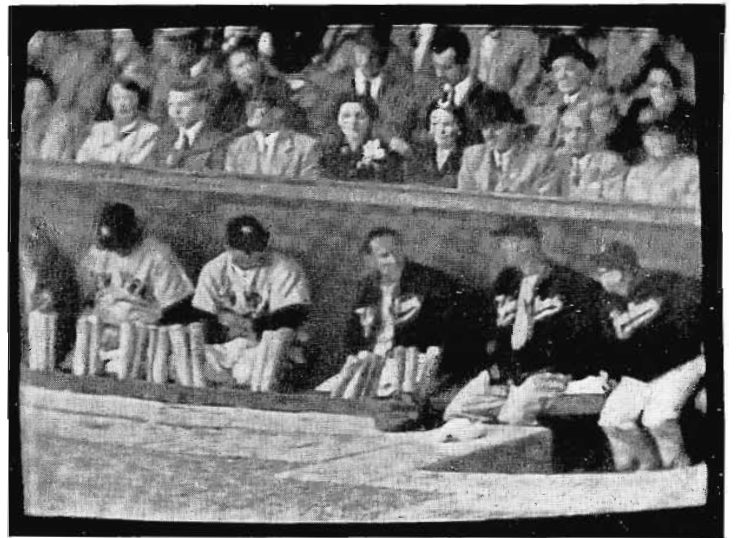

FIG. 19. Or, if he chose, he could use this closeup to show the next batter getting up to select his bat, etc.

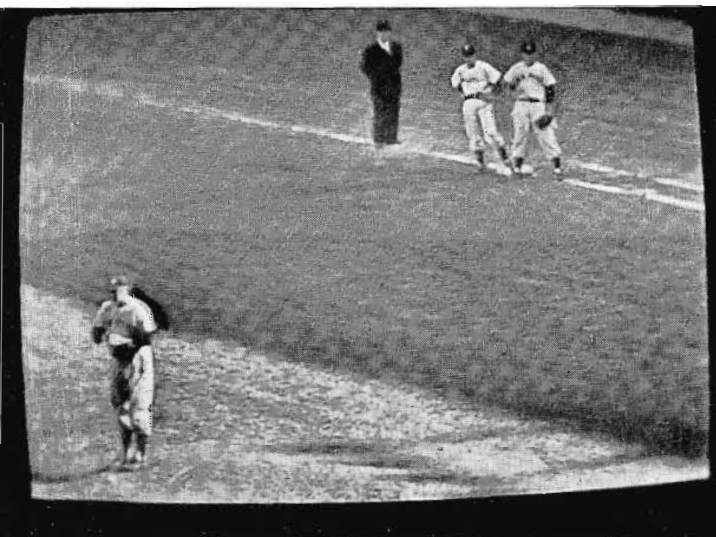

FIG. 20. No. 3's angle was ideal for picking up the action of a pitcher trying to catch a man off first.



FIG. 21. No. 3 was also used (as an alternate to No. 2) for following fly balls to outfield and zooming in on catch.



FIG. 22. In the case of left-handed batters the No. 3 Camera was used to show the batter coming up to the plate.

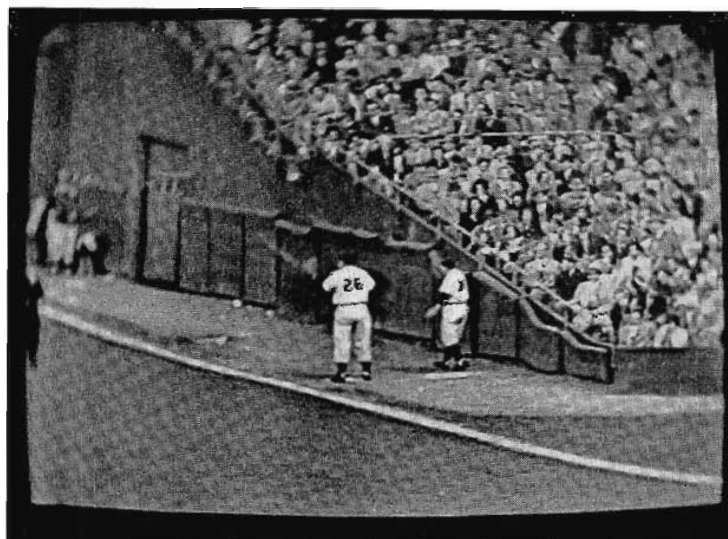

FIG. 23. This is the view of the visiting team (Yankees) bullpen as seen with No. 3's Zoomar lens.

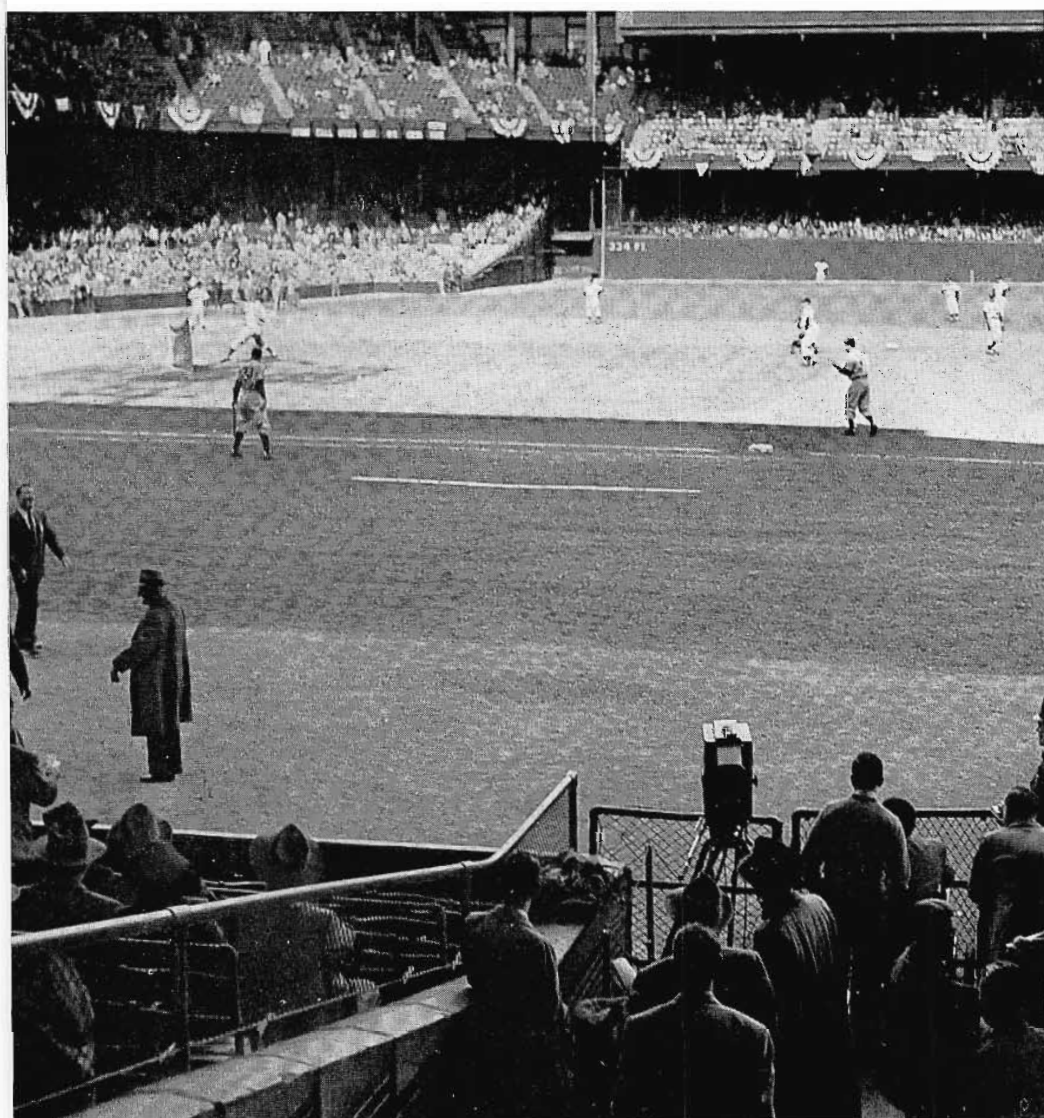

FIG. 24. The No. 4 Camera was located practically at ground level, just a little beyond first base. This picture, made during batting practice, shows the No. 4 location in lower foreground.

CAMERA No. 4 - Low Opposite First

The second camera which WPTZ added for the Series was placed at ground level on the right field side about in line with first base. This position (shown in the illustration at left) gave the rather unusual effect of looking up at the pitcher (as he stood on the mound) and at the batter at eye level. The latter was a particularly outstanding shot of right-handed batters in that it showed their facial expressions to a degree never approached by higher-located cameras. Similarly, the eye-level views of the coaches at first and third, the infielders crouching for a bunt, the "rhubarbs" with umpires, and similar "color" shots were superb. A few of these shots are shown on the opposite page.

It was also possible, with this camera, to show a closeup of the pitcher winding up and throwing, the ball traveling to the plate and the batter swinging (?) at it. In the pre-Series experiments this was given a trial. However, the camera panning required to follow the ball was rather disconcerting. Moreover, the lack of perspective made it hard to "orient" the viewer when the ball was hit. Apparently the technique was considered unsatisfactory as it was little (if any) used during the Series itself.

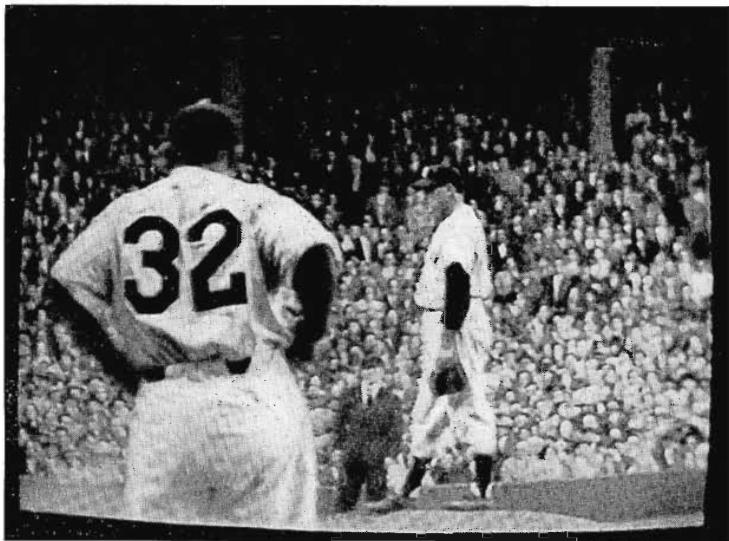

FIG. 25. Camera No. 4 provided this novel "looking-up-at-the-pitcher" view with its 17-inch lens.

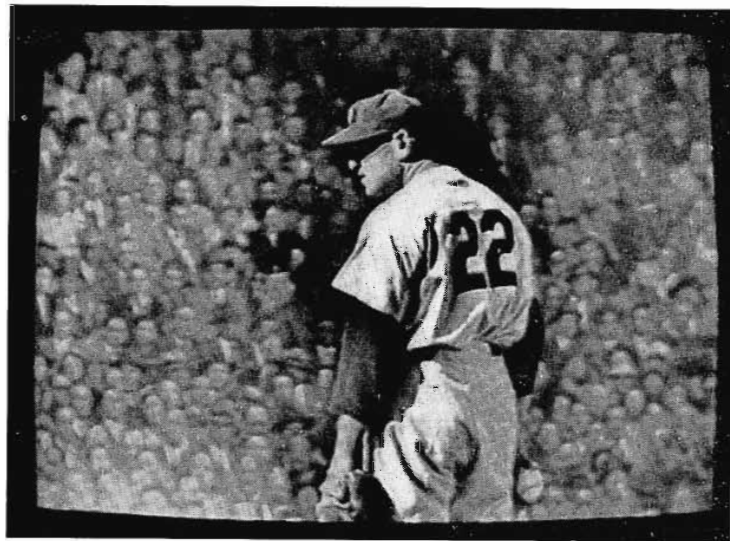

FIG. 26. With the 25-inch lens on No. 4 Camera the TV viewer could see the pitcher better than the batter could.

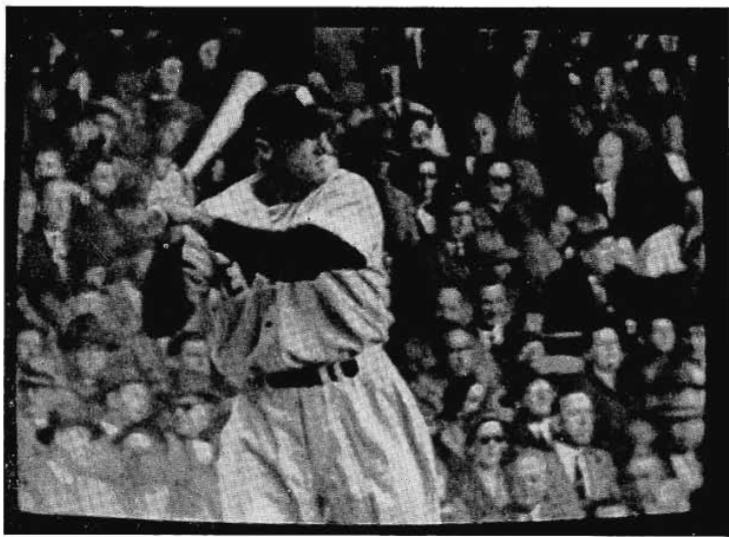

FIG. 27. No. 4 was also used for closeups of right-handed batters—either with the 25-inch lens, as here, or with the 17-inch lens.

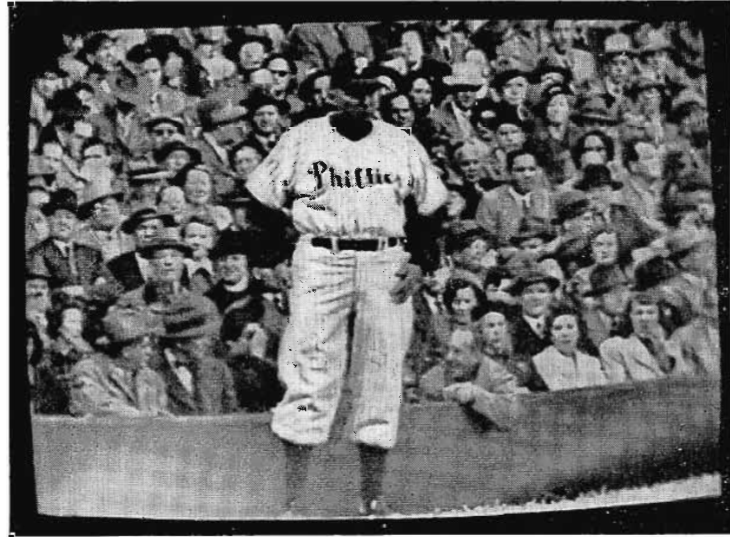

FIG. 28. Depth of focus is illustrated by this No. 4 shot of Phillies Manager, Eddie Sawyer, coaching at third.

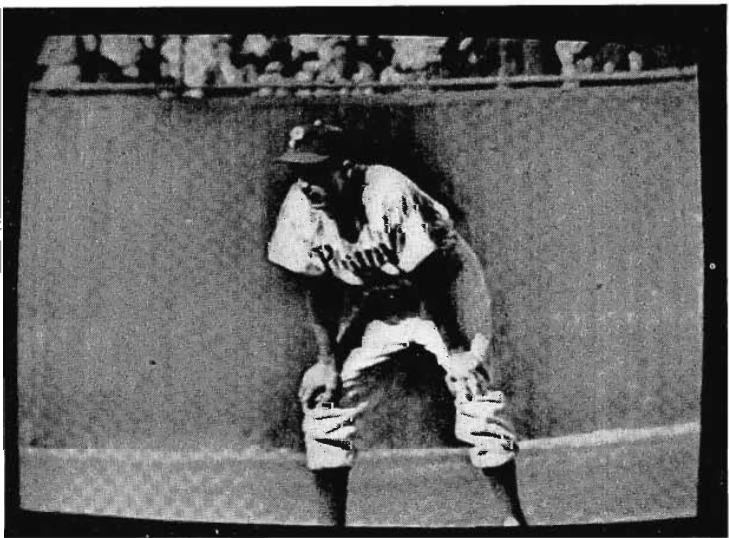

FIG. 29. Phil's Eddie Waitkus takes lead off second. Left field stand, behind him, is actually 200 feet away from him.

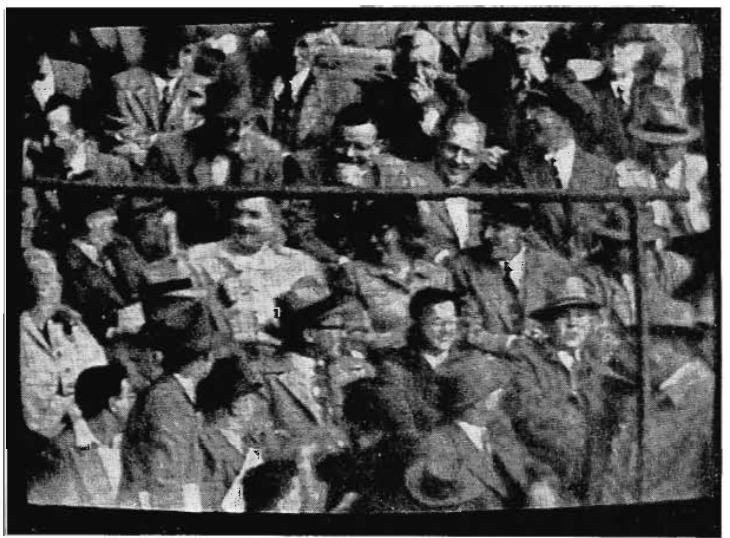

FIG. 30. Another shot with Camera No. 4's big 25-inch lens. This one is of the crowd behind homeplate.

A PROFESSIONAL TAPE RECORDER

By **W. E. STEWART**
Manager,
Broadcast Audio Engineering Section

Introduction

In approaching the design of a magnetic tape recorder for broadcast station use, the RCA engineers established a set of specifications based on the widest possible experience. It included requirements of many broadcasters in all sizes of stations. It met rigid specifications established by national networks having several years experience with various makes of recorders. Recording studios were also consulted. Many points were established by exhaustive laboratory tests.

Such outstanding features as accurate timing, low wow and flutter, plus quick starting with push-button control were considered vitally important. Thus, the resulting machine (RT-11A) described below incorporates all these essential qualities for a truly professional tape recorder.

General Description

The basic recorder consists of four major parts: the tape drive unit; power supply; recording amplifier and reproducing amplifier.

The magnetic heads are a part of the tape drive unit. An interconnecting harness is also supplied to simplify installation as much as possible. A number of accessory items can be included such as the Remote Control Unit, MI-11948 (see Fig. 5).

Tape Drive Unit

This basic item was designed to mount in a standard cabinet rack. At the same time, care was taken that none of its operations depended on gravity so it could be mounted in any other desired position. In particular, it was expected that some users would prefer a horizontal console type machine.

Considerable study was necessary to determine the best layout of the panel for all operations. It was realized that threading time is of primary interest in a broad-

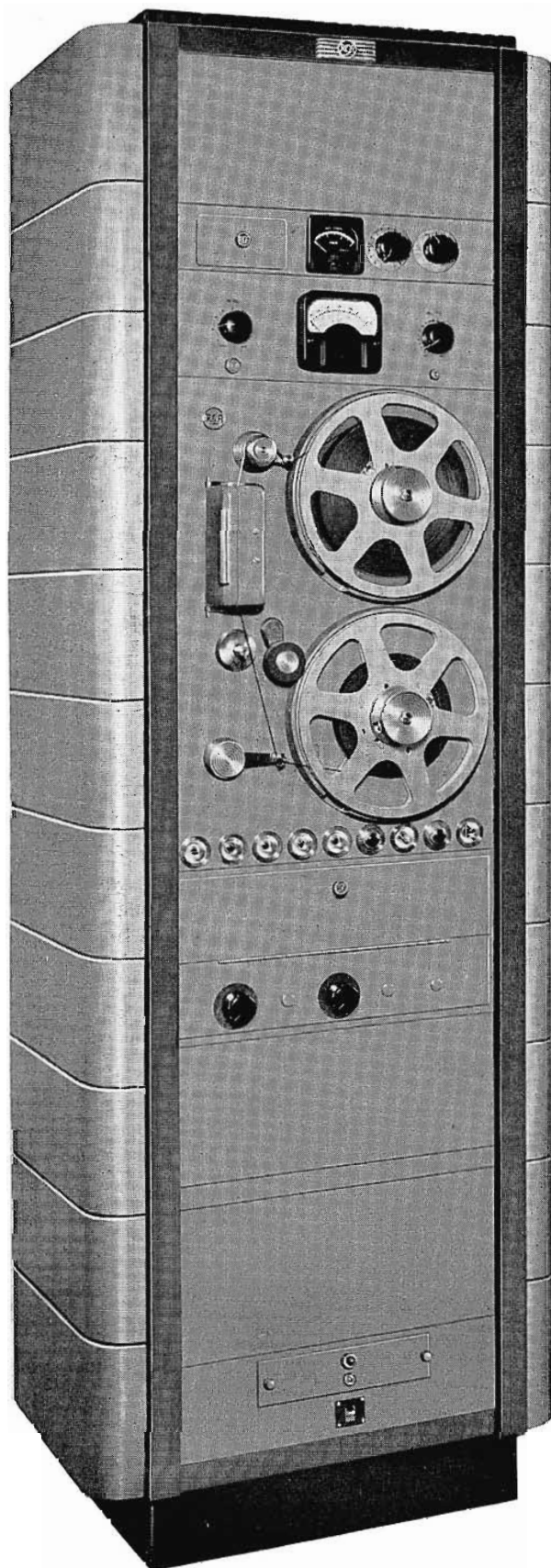
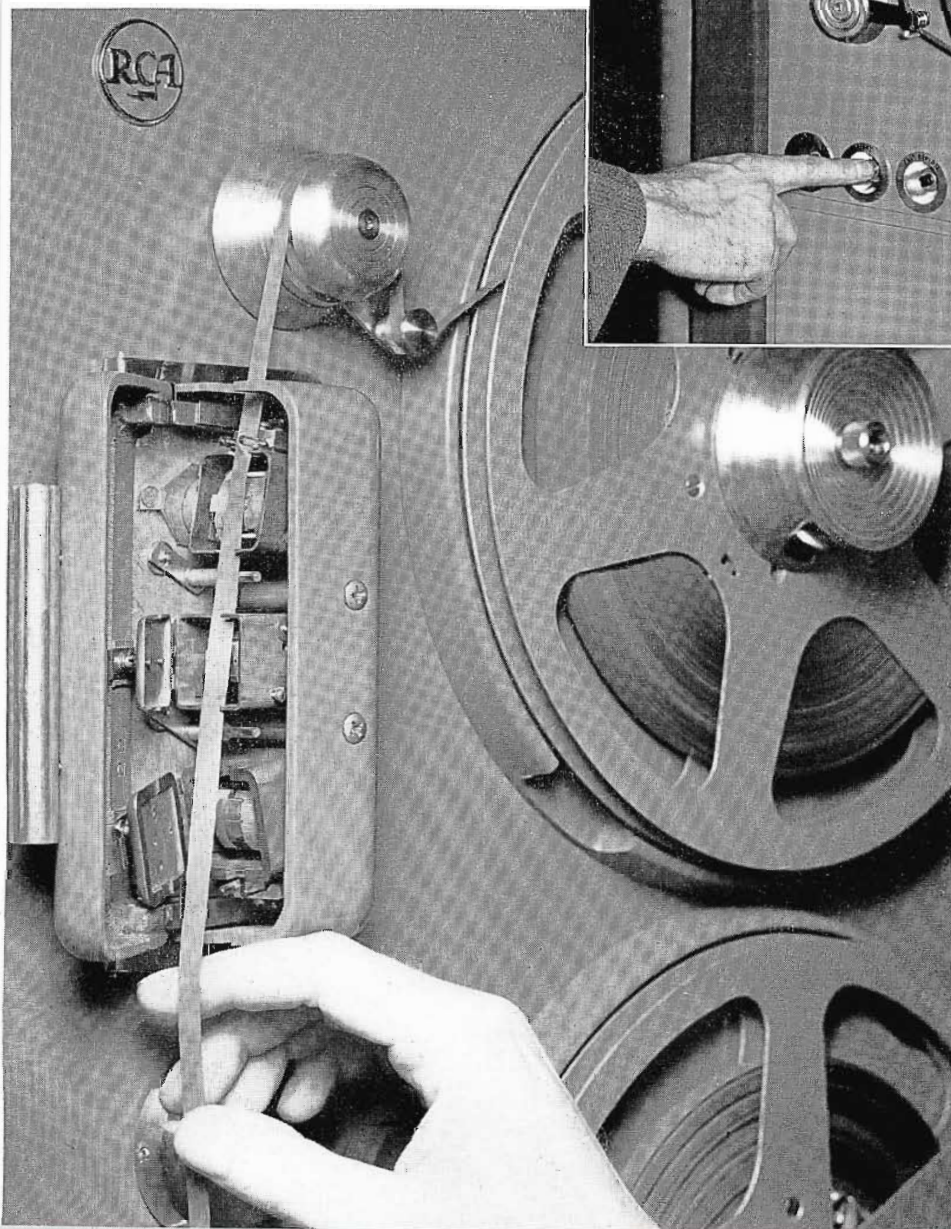
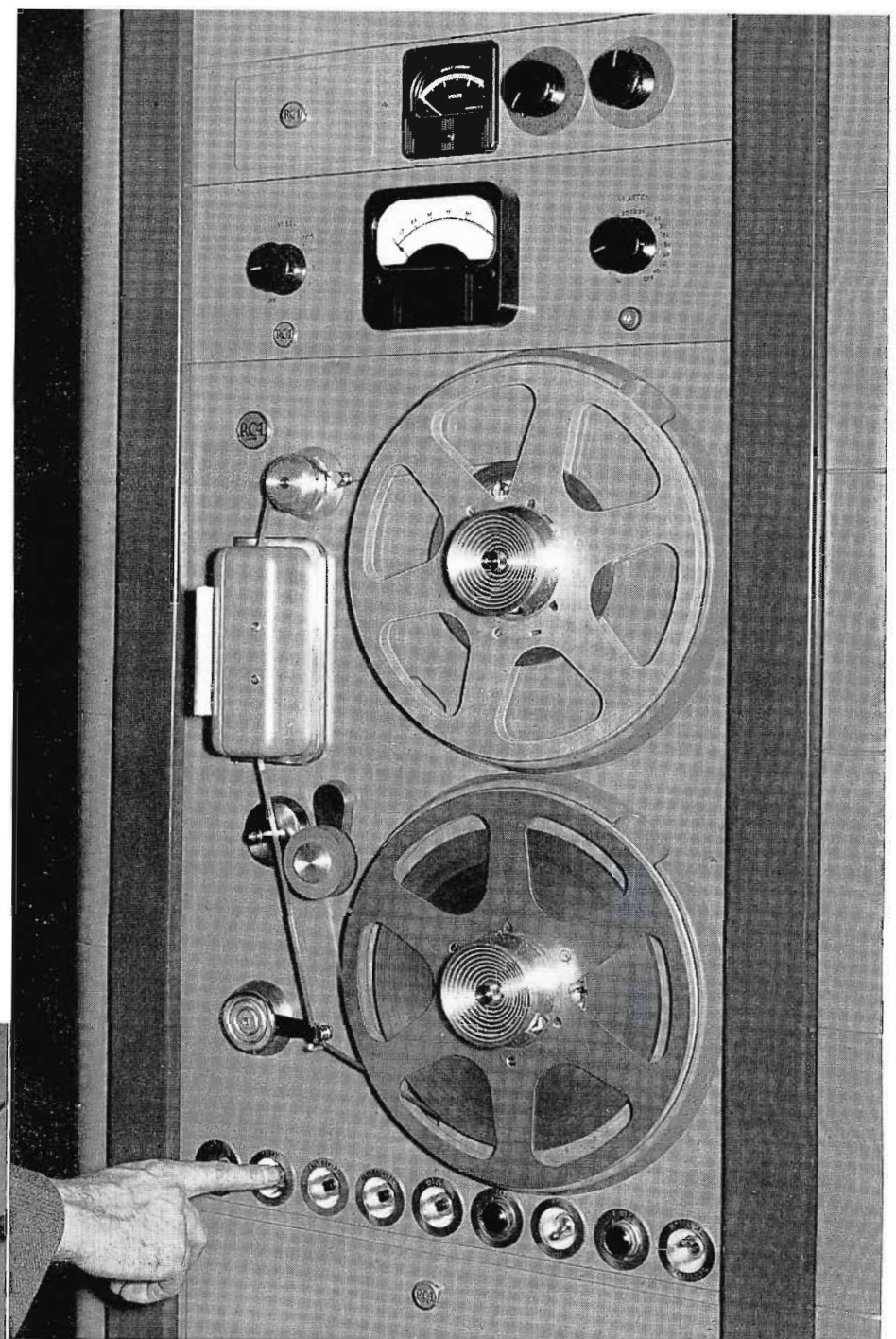

FIG. 1. The RT-11A Professional Tape Recorder (consisting of tape drive unit and panel and shelf directly below) shown mounted in a BR-84 series cabinet rack. Other rack and panel items such as the two meter panels at top of cabinet, and the switch and fuse panel at bottom of cabinet are available as accessory equipment.

FIG. 2. Closeup of RT-11A Recorder showing convenient recessed push-button control arrangement.

cast station. Tests indicated that when the machine was rack mounted, the tape must thread from top to bottom for fastest threading. Both right and left hand threading and various combinations of reel motion were tried. At the same time, experience indicated that when the machine is used in a horizontal position, the tape must move from the left hand to the right hand reel. Furthermore, the tape must move around the front side of the board to be easily accessible for editing. The tape path shown in Figs. 1, 2 and 3 resulted. For those who feel that this might be "left-handed" it is pointed out, that after many years of film projector design, almost every projector on the market threads down the left side of the reels.

In the horizontal position the machine may be used for editing, and it will be



desirable to draw the tape over the heads and into a wastebasket (without putting it on the takeup reel). This fixed the position of the capstan as *after* the heads. A pusher type tape path would make this operation impossible. For editing purposes, it was desirable that the head shields open very wide so the tape would be drawn straight out for marking and cutting. Fig. 3 shows how both the inner and outer covers open widely.

It will be noted that the vertical and horizontal requirements are both answered completely by the final arrangement. The

FIG. 3. Closeup of the Tape Recorder Head showing how easily the head shields are opened and closed during tape threading.

utmost convenience and safety in threading and handling the tape is assured. All the controls were recessed so they would not interfere with the tape during the threading operation. Sharp angular projections were avoided throughout (see Fig. 2).

Full remote control of the machine was desired. This called for relay and solenoid operation of all functions. See Fig. 4. It also made complete interlocking of all functions comparatively simple. Since high speed travel of the tape over the heads makes unnecessary wear and damage, a solenoid lifts the tape on sapphire guides whenever it is in high-speed forward, or rewind positions. These lifters and guides can be seen in the closeup of Fig. 9 between the individual heads.

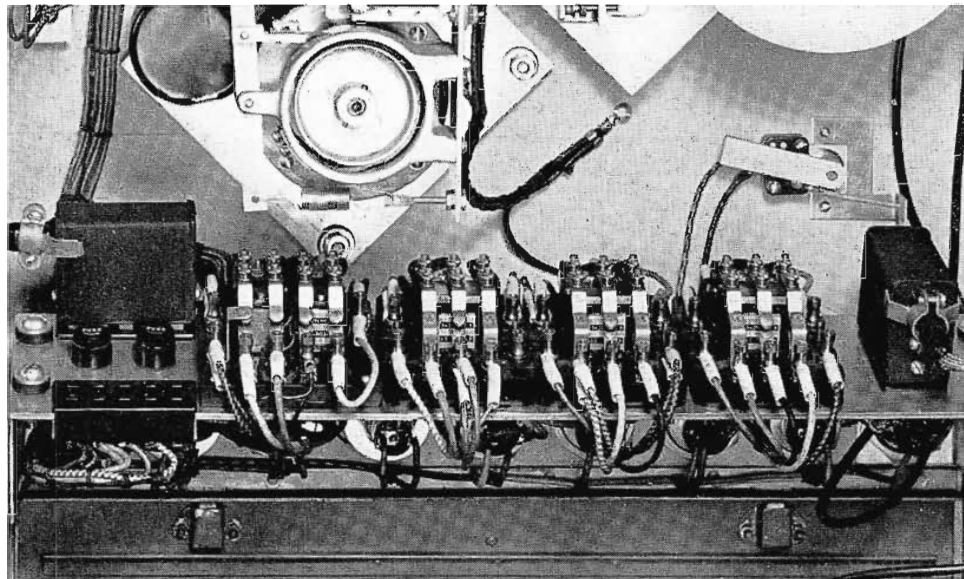

FIG. 4. Closeup of a bank of RT-11A relays. (Relay and solenoid control operation is provided for all functions.)

Controls

The control circuits are arranged as follows:

1. **POWER SWITCH**—A toggle switch turns on the a-c power. This may or may not turn on the amplifiers depending on how the broadcaster desires his installation. The capstan motor is started by this switch and requires about as much time to reach full speed as the tube filaments require for warm up. The control circuits are not energized until this switch is on. A pilot lamp shows when the power is turned on.

2. **SPEED SELECTION**—This toggle switch selects the capstan motor speed for either 7.5 or 15 inch/sec. tape speed. It also operates a small relay in each of the amplifiers to adjust compensation for each speed.

3. **START**—The "Start" push-button switch starts the tape moving over the heads at normal speed. The actual functions accomplished are: removes brake load from reel motor; energizes reel motors and pushes the pressure roller against the tape and capstan (moving the tape at capstan speed).

4. **RECORD**—The "Record" push-button switch starts the recording function. A "Record" lamp indicates that the machine is recording (and erasing what had been on the tape). The actual functions performed by this operation are: unshorting the recording head; applying plate potential to the oscillator circuit and lighting the "Record" lamp.

This function is electrically interlocked so it cannot be operated until the "Start" button has been pushed. If it is desired to start recording immediately upon starting the tape, the "Record" button can be held down while the "Start" button is pressed.

5. **FAST REVERSE**—This push-button switch effects rapid rewind of the tape. The functions performed are: releases "Record" functions if they were energized; releases the capstan pressure roller if it was energized; energizes the tape lifter mechanism; applies heavier torque to the supply reel motor so the tape rewinds.

This circuit overrides any of the other circuits and can be operated without first pressing the "Start" button.

6. **FAST FORWARD**—This push-button switch effects rapid forward winding of the tape. Its functions are the same as "Rewind" except for the direction of the tape. "Rewind" overrides "Fast Forward" if both buttons are pressed at once. The two may be pushed alternately to obtain exact placement of the tape.

7. **STOP**—This push-button switch stops the tape quickly. It de-energizes all the above circuits applying the brakes to the reels, leaving the pressure roller and tape away from the capstan and the tape lifters down. The bias oscillator plate voltage is removed and the recording head shorted.

The follower arm contains a safety switch which will also stop the machine and apply the brakes if the tape should break or come to an end.

The control switches and lamps are located at one end of the panel so the hands do not have to be placed close to the moving parts of the machine. The most used positions are at the left (front when horizontal) and the least used are at the right (or rear). In order, from left to right, they are: Stop, Start, Fast Reverse, Fast Forward, Record, Record Lamp, Power, Power Lamp and Speed Selector.

Remote Control

The application of remote control is quite simple. The same type push buttons are used and can be mounted in any manner the user chooses. A nine-wire cable is required from the remote control position to the motor board. A Jones plug-in connector is used for actual connection; one jumper must be clipped when the remote control connection is plugged in.

The above switches are obtainable mounted in a suitable panel on a box as MI-11948. Stop, Start, Fast Reverse, Fast Forward, Record and Record Lamp may all be extended in this manner. In operation, any function can be performed from either the local or remote position regardless of where the last operation was performed.

Reels

As has been mentioned, torque motors have been used for the reels. A brake is applied at the rear end of the shaft. Study of the brake lining resulted in a material that applied the proper torque with com-

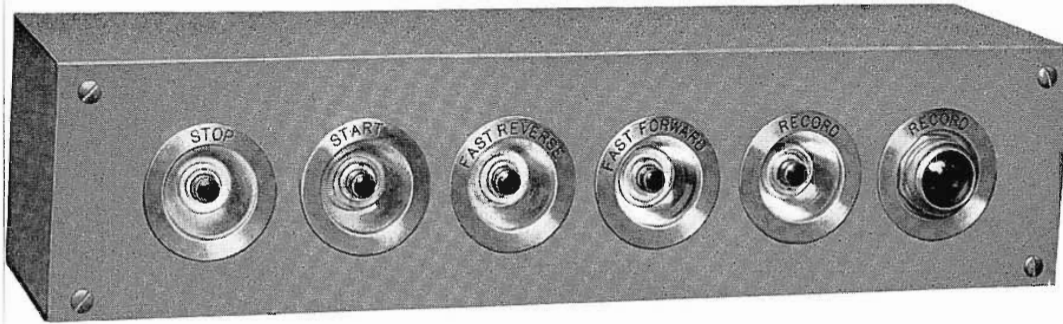

FIG. 5. Remote control unit, MI-11948, is available for easy extension of all recorder operations to remote positions.

paratively low tension. It was thus possible to use a low power winding on the solenoid and operate within safe temperature limits even when used continuously.

A standard NAB reel can be placed on the hub, or removed, without removing the hub itself. A flat circular spring holds the reel in place and no special locating pins are involved. To use the smaller RMA reels, the hub is removed from the shaft, the reel put in place and the hub pushed in against it. A simple finger latch releases the hub. If only NAB reels are to be used, a knurled nut at the center can be used to lock it more tightly. Tens of thousands of off-on cycles with a full reel of tape were used in a life test to check the new hub and the brake design.

Tape Motion

Smooth tape motion is one of the most important requirements in a high quality recorder. More than twenty motor designs from several companies were tried in arriving at a satisfactory tape drive system.

The simplest drive system, and one giving synchronous capstan operation, is a direct drive in line with the motor shaft. This has several disadvantages, however. If a normal speed motor is used, the capstan becomes quite small and exceedingly rigid limits must be set to avoid flutter from capstan irregularities. Also it is difficult to filter out the motor pulsations without adding a high compliance device that adds a wow or flutter at some objectionable frequency. If a special low speed motor is used, then the hunting in the motor field can add a similar wow. Many systems were tried before discarding the direct drive idea.

The use of a speed reduction device makes a larger capstan possible with more

practical manufacturing tolerances resulting. The RT-11A capstan shaft is supported by a sleeve bearing at the front (or tape) end to give the smoothest possible motion at the critical end of the shaft. The surface contacting the tape is ground after assembly to assure perfect

concentricity. The rear bearing, which must support a heavy fly wheel, is a precision ball bearing.

Since accurate timing is an important requirement in broadcast stations, the capstan must be synchronous with the power supply. A timing belt giving a 3 to 1 speed

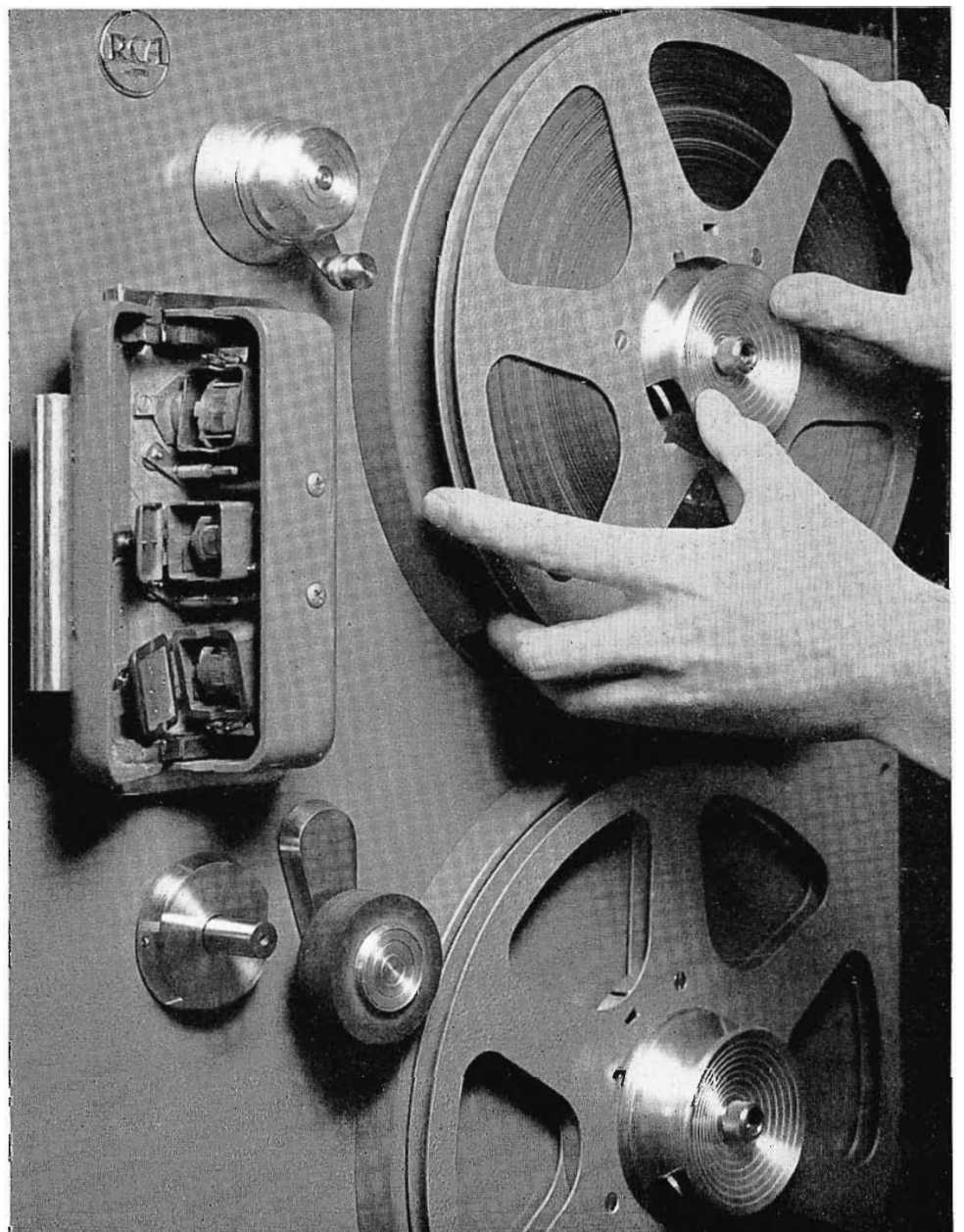
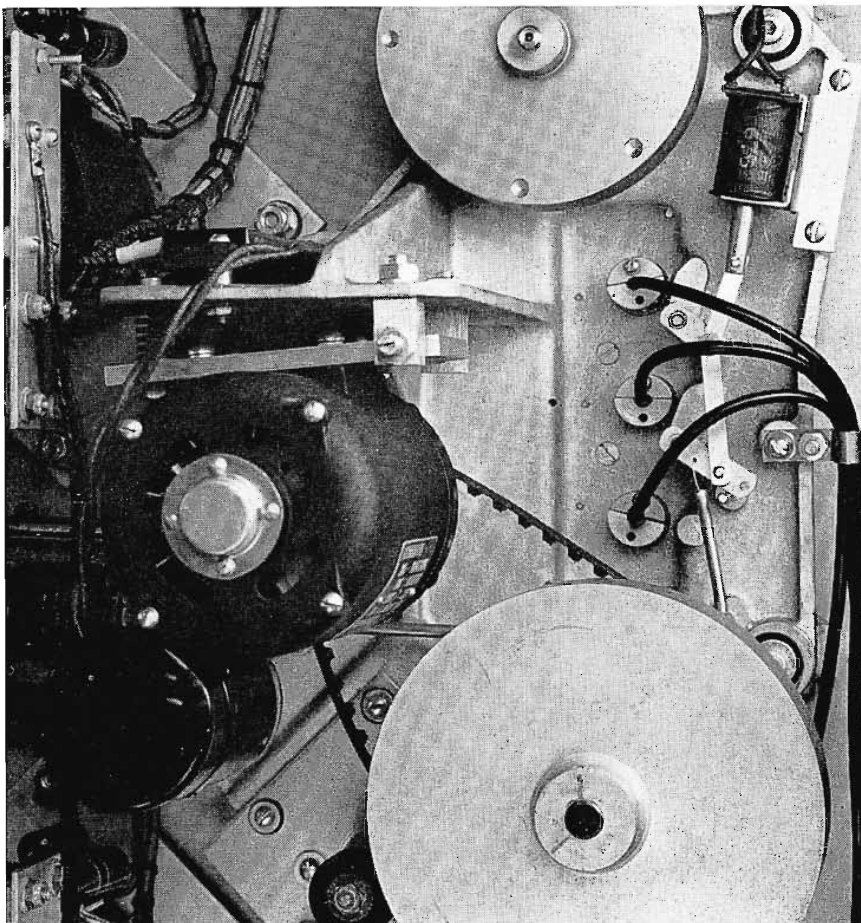
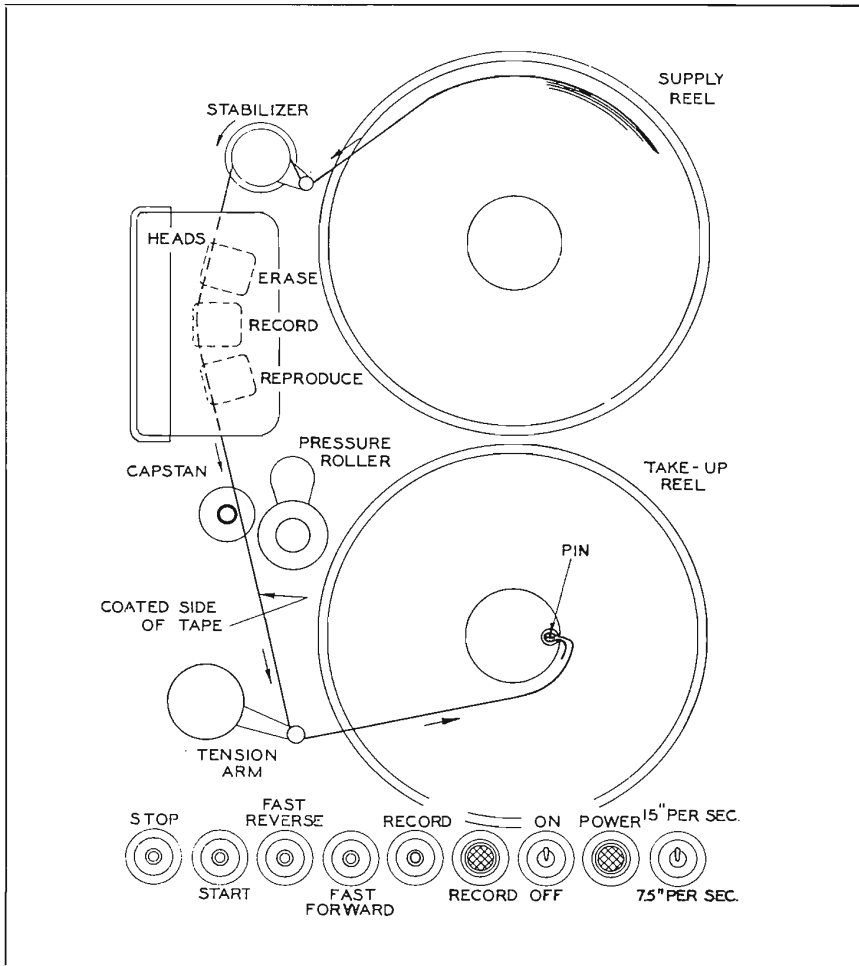

FIG. 6. "Snap-on" type reels can be placed on the hub, or removed without removing the hub itself. Either NAB or RMA reels may be used with the RT-11A.



reduction was found satisfactory for this purpose. Careful measurements failed to show any significant amount of flutter from the cogs in the belt.

It was found that a small fly wheel driven by the large one through a rubber idler damps out any tendency to oscillate. In starting, there is a single, small transient lasting approximately one second but no tendency to oscillate or hunt.

Thus, a tape drive system is achieved that is synchronous, and that exhibits very low wow and flutter values in starting and in operation. The very small amount of wow and flutter remaining is a complex function, reflecting minute variations in the several rotating parts, tape irregularities, vibration from the floor, etc. This has been carefully evaluated by laboratory tests and is less than .1% r.m.s. However, r.m.s. measurements are difficult to make, so a series of peak measurements are used in production to ascertain the peak value and evaluate the frequency range in which the wow and flutter occurs. The limit for the combined value is .15% peak (.3% peak to peak) while the NAB standard has been set .2% (.4% peak to peak).

Experience has shown that a panel-mounted machine is often hard to keep properly aligned. The slightest warping of the panel changes the tape path slightly and requires realignment of the heads for good high-frequency response. For this reason, all of the important parts of the tape guiding mechanism are mounted on a casting which floats on the panel. The stabilizer, the motor and capstan, the pressure roller and the heads are all mounted on a rigid casting. This casting is mounted in heavy rubber grommets in a three-point suspension system. All the above parts that appear on the front of the panel are actually mounted on the casting and have a small clearance between them and the panel. A closeup of the casting and associated parts appear in the photograph of Fig. 8. In addition, the tape is closely guided in and out of the heads by sapphire guides. The sapphires may be rotated and moved slightly from time to time to avoid excessive wear in one spot.

FIG. 7 (top left). As shown in this sketch, a simple, "easy-to-thread" tape path is employed in the RT-11A Recorder.

FIG. 8 (at left). All components of the tape guiding mechanism are mounted on a casting which floats from the panel.

Heads

The design and manufacture of good tape recording heads are so important to the proper functioning of a professional tape recorder, that they could be the subject of a complete paper in themselves. They are necessarily mentioned briefly here.

1. ERASE—Fig. 9 gives a closeup view with the erase head at the top and the reproduce head at the bottom. The erase head core is made of .002" laminations of silicon steel. Silicon steel gives high flux density to increase the effectiveness of the erasure.

A double-gap design is arranged so the tape is, in effect, erased twice in a single pass. No pre-erasure is necessary to assure clean, quiet tapes when using this recorder.

The head is mounted in a copper shield can to reduce radiation of the 100 kc erasing frequency.

2. RECORD—The record head must perform an entirely different function than the erase head and consequently has a different structure. An 80% nickel-iron alloy is used for the laminations, and the single gap must have very straight, square edges. The losses must be low at high frequencies.

To assure no beat between the bias frequency and the higher audio frequencies, 100 kc is used for the bias. This requires very thin laminations in the head cores.

The head is shielded with a single layer box of nickel-iron alloy. A hinged lid closes tightly on the box leaving entering and exit slots for the tape.

3. REPRODUCE—This head is the most critical of all three. The signal obtained from the tape is very small, being less than that from broadcast microphones. This means that there must be extremely good shielding from hum fields. A triple shield is used: two layers of nickel-iron alloy with a layer of copper between. A low impedance winding is used to reduce electrostatic pickup and to allow long leads from head to amplifier when necessary.

Otherwise, the construction of the head is similar to the record head, except that the gap must be built to even more rigid

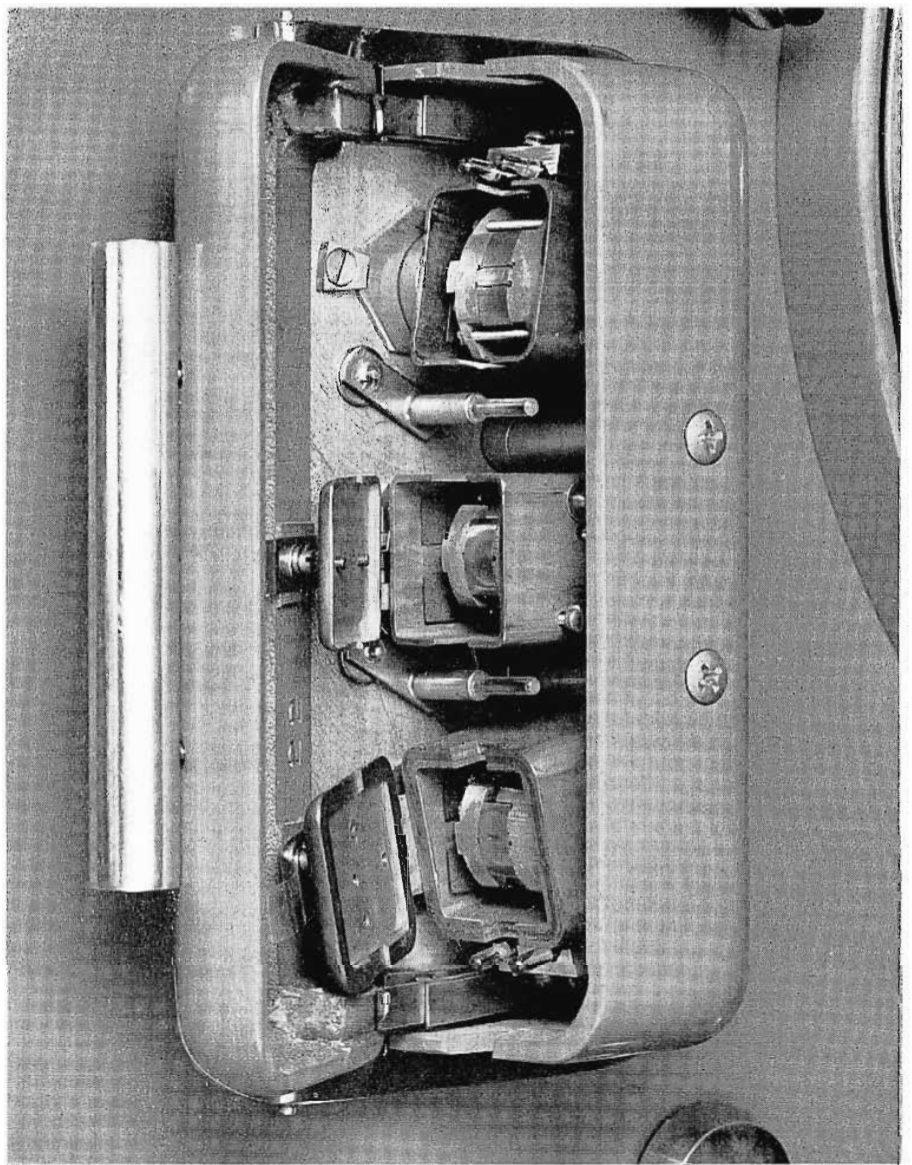

FIG. 9. Closeup view of the completely shielded, single-unit recorder head which accomplishes all three functions ("Erase," "Record" and "Reproduce").

specifications. The tolerances on the dimensions and delineation of the gap are comparable with those called for in optical work. Both machine and hand lapping are used in the manufacturing process, and a microscope inspection is part of the final test.

Azimuth adjustment of this, and the recording head, are available by taking off the outer cover.

The slots in the shields are wide enough to allow the tape to be lifted off the heads without opening the covers. Remote rewind and fast forward is not practical, if the covers must be opened manually for these functions.

Both the outer and inner covers open very wide to allow easy threading and inspection of the heads.

Amplifiers

The amplifier portion of the recorder is divided into three parts (see Figs. 10, 11

and 12). Each occupies 1/3 of a standard BR2A shelf and is equipped with the standard RCA plug-in arrangement. These three units are the power supply, the recording amplifier and oscillator, and the reproducing amplifier.

Power Supply

The power supply is a simple arrangement consisting of a transformer, type 5Y3G rectifier and RC filter. Filament power is also supplied by the transformer. The chassis contains a power switch, fuse, and hum adjusting potentiometer available at the front end of the chassis.

Recording Amplifier and Oscillator

The recording amplifier is a three-stage amplifier, and is comparatively conventional in form except for the output. There, it is necessary to add the bias frequency and the high-frequency compensation for recording losses. The compensation is added

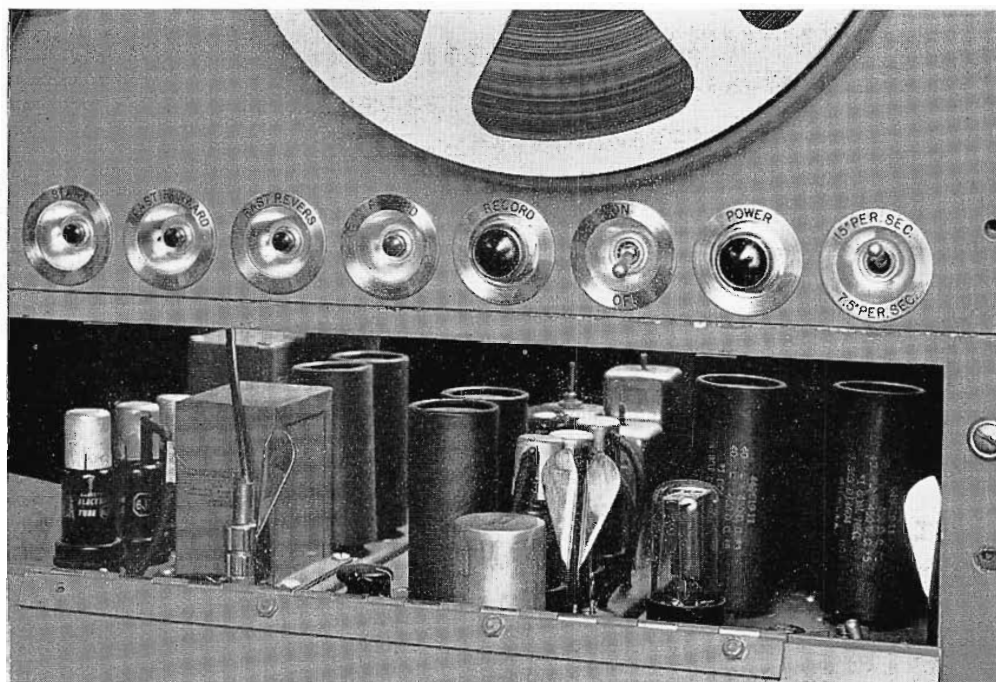

FIG. 10. The Recording Amplifier, Reproducing Amplifier and Power Supply units are all RCA "Plug-in" design and are located on a BR-2A shelf as shown above.

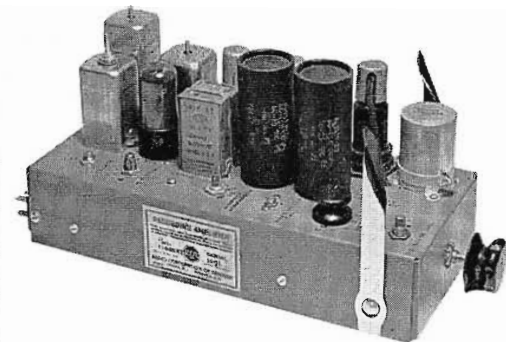

FIG. 11. The "Plug-in" Recording Amplifier.

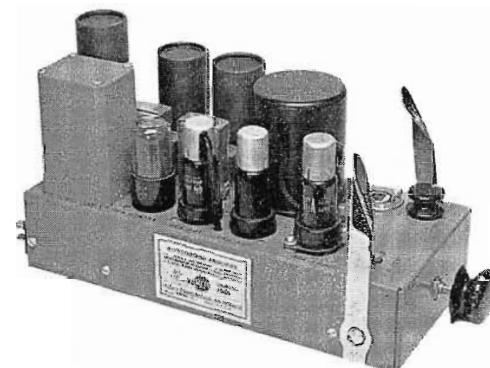

FIG. 12. The "Plug-in" Reproducing Amplifier.

in an inverse feed back circuit. The VU metering position is then by-passed in such a manner that it reads the response as if it were flat. The VU meter is placed in the circuit so the bias frequency is trapped out. It will be noted that the meter reads recording level at the recording head, assuring the operator against amplifier failure without his knowledge.

A 6V6 on the same chassis supplies the erasing current as well as the bias. The bias frequency is set at approximately 100 kc. This is more than six times the highest audible frequency recorded and precludes the chance that harmonics of the audio frequencies might beat with the bias and cause "birdies".

The input circuit is normally arranged for 20,000 ohms bridging. With this connection, signals of -10 dbm will produce maximum recording level on 3M type 111 RBA tape. This corresponds to a program level of -20 VU. The input circuit may be reconnected internally, by "jumping" the bridging resistors and removing a resistor for 600-ohm matching input. Taps are available on the transformer for 150-ohm input. When used in matching position, a -45 dbm (-55 VU) signal will produce maximum recording level on the tape.

The high gain supplied by this amplifier makes auxiliary amplifiers unnecessary in all normal situations. It can be bridged

on to distribution busses or matched into mixer circuits or lines.

Reproducing Amplifier

The low impedance head makes it possible to use comparatively long leads from head to amplifier without electrostatic pickup or loss of high frequencies. A feedback circuit around the first stage supplies the special frequency response necessary to match the head. A relay changes the compensation when the tape speed is changed. The filament of the first tube is supplied with d-c by a rectifier on the chassis, and the input transformer is triple shielded to lower hum to the lowest possible value. Frequency-response compensation is also carefully balanced to bring hum and high-frequency noise to approximately the same residual value. Only by these measures can consistent performance at 60 db signal-to-noise be obtained.

The remainder of the amplifier is comparatively straight forward with a pentode amplifier in the second stage, phase inverter, and push-pull output. This output level is $+24$ dbm ($+14$ VU) ± 2 db for maximum recording level on the tape. The

FIG. 13. Overall frequency response characteristic of the RT-11A Recorder.

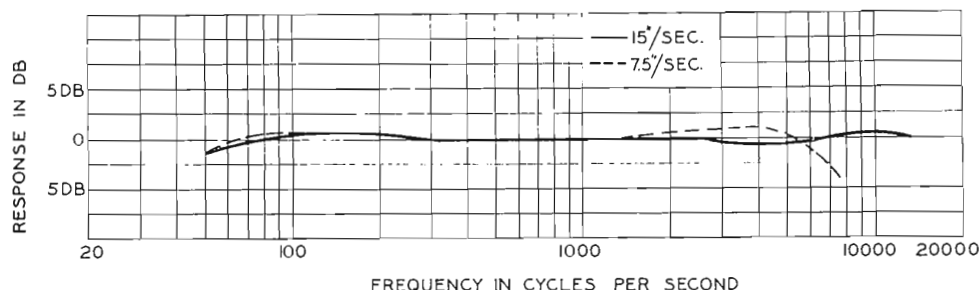

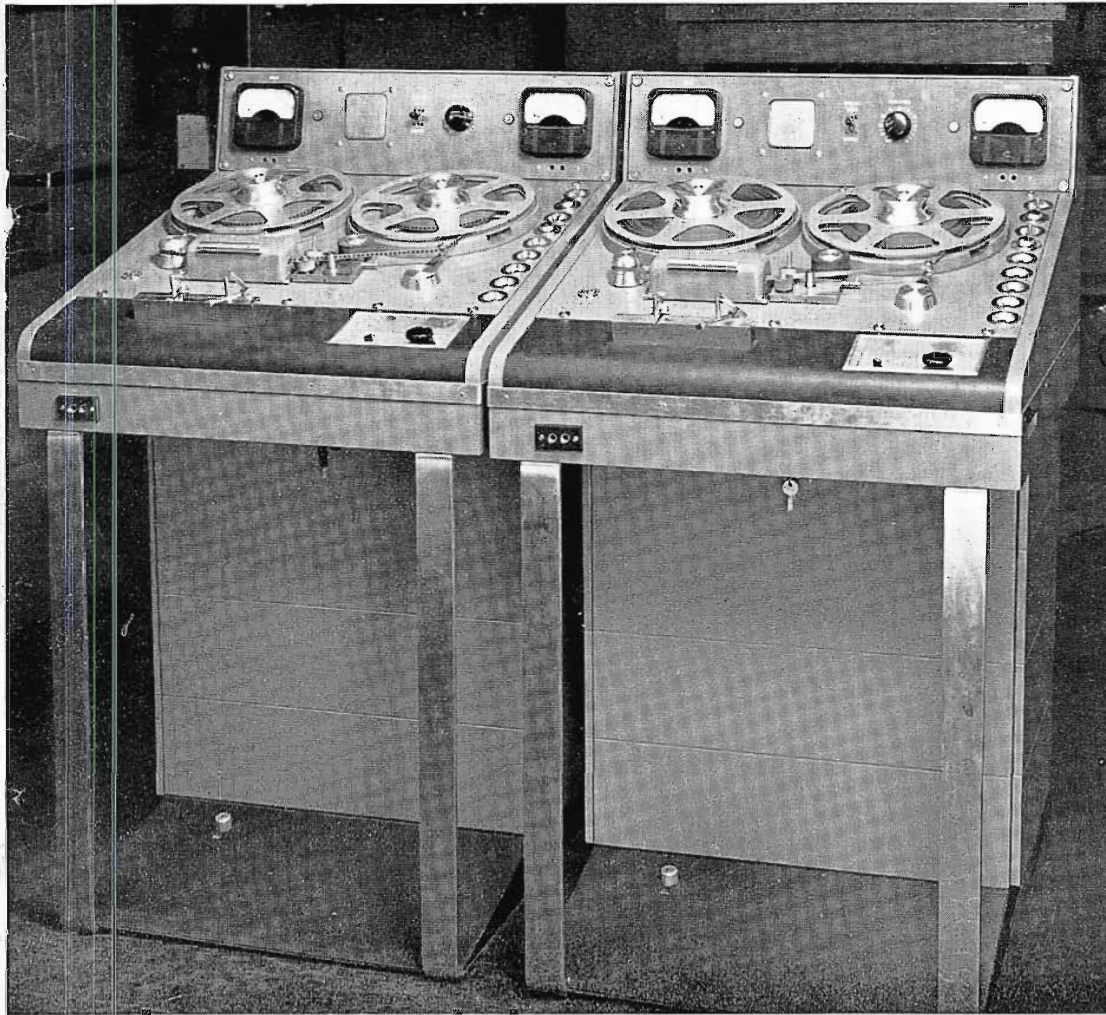

FIG. 14. Front view of a custom setup of two RT-11A Tape Recorders mounted in a special console arrangement.

level is sufficient to feed the distribution busses direct with no auxiliary amplifier needed.

Harness

A wiring harness is supplied with the recorders to make installation simpler. The same harness will fit rack and shelf mounting, and console mounting. The plugs are already wired in place and need only mechanical installation. Input, output, power, and metering leads are the only extra connections needed. The plugs are so mounted in the amplifiers and harness that no unit can be plugged into the wrong position.

Special "Custom" Applications

The component parts of the RT-11A have been designed so that a number of

"operating-setup" variations are possible. One very special arrangement of parts resulted in the editing machine which will be described in an article by Mr. D. C. Yarnes in a future issue of BROADCAST NEWS.

Another arrangement, less special, but still custom built, is indicated in Fig. 14. These two recorders are part of a special order built to network specifications. The tape handling mechanism and amplifiers are standard, but their console arrangement and several other features are special. These features include the following. A foot switch is provided to release the reel brakes for easy handling of the tape while editing. A tape marking device provides fast identification of cutting spots on the tape. This is shown in Fig. 15 as are the two rollers on the plate at the capstan. This is more fully described in the article on editing mentioned above. A cutting and splicing bar is mounted at the front. Two meters and switching and monitoring facilities are provided for incoming and outgoing circuits. Knee room is provided for the operator.

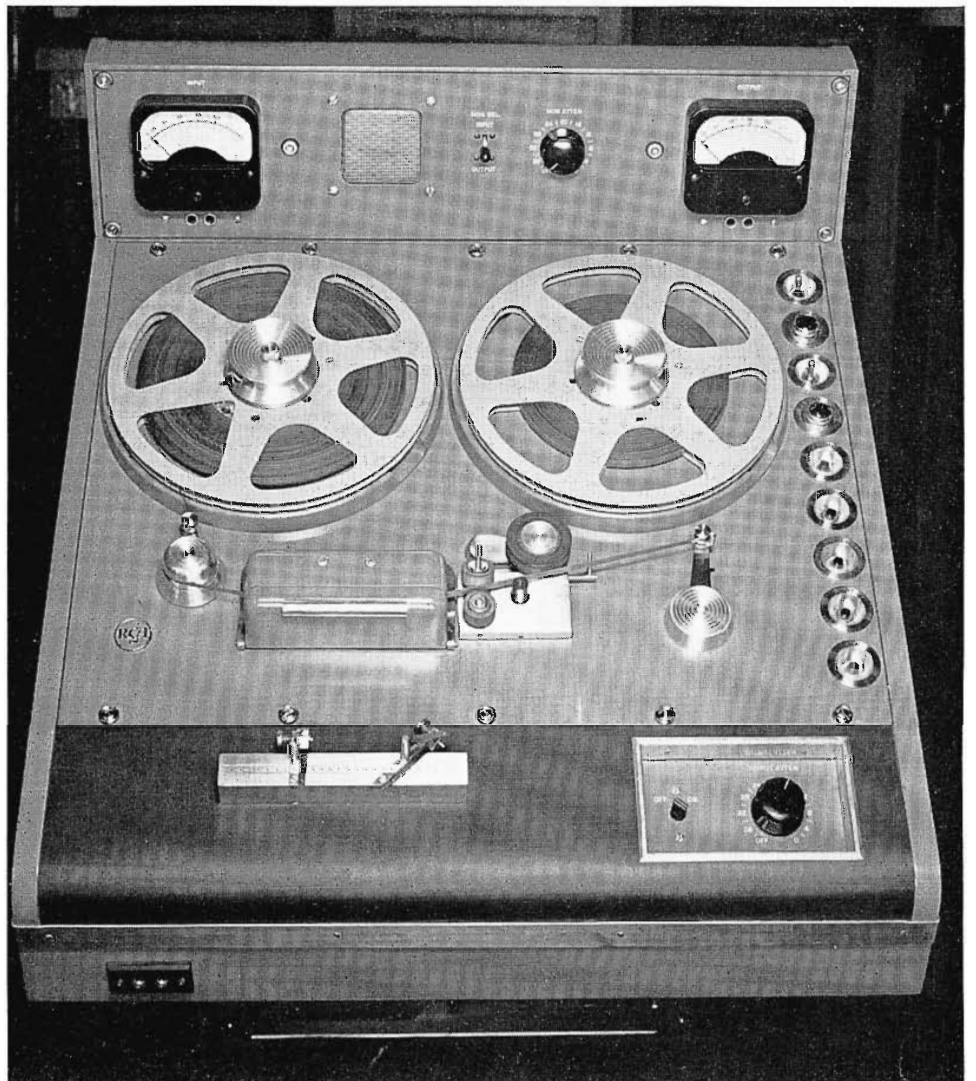

FIG. 15. Closeup view showing the tape drive unit and a special tape marking device provided.

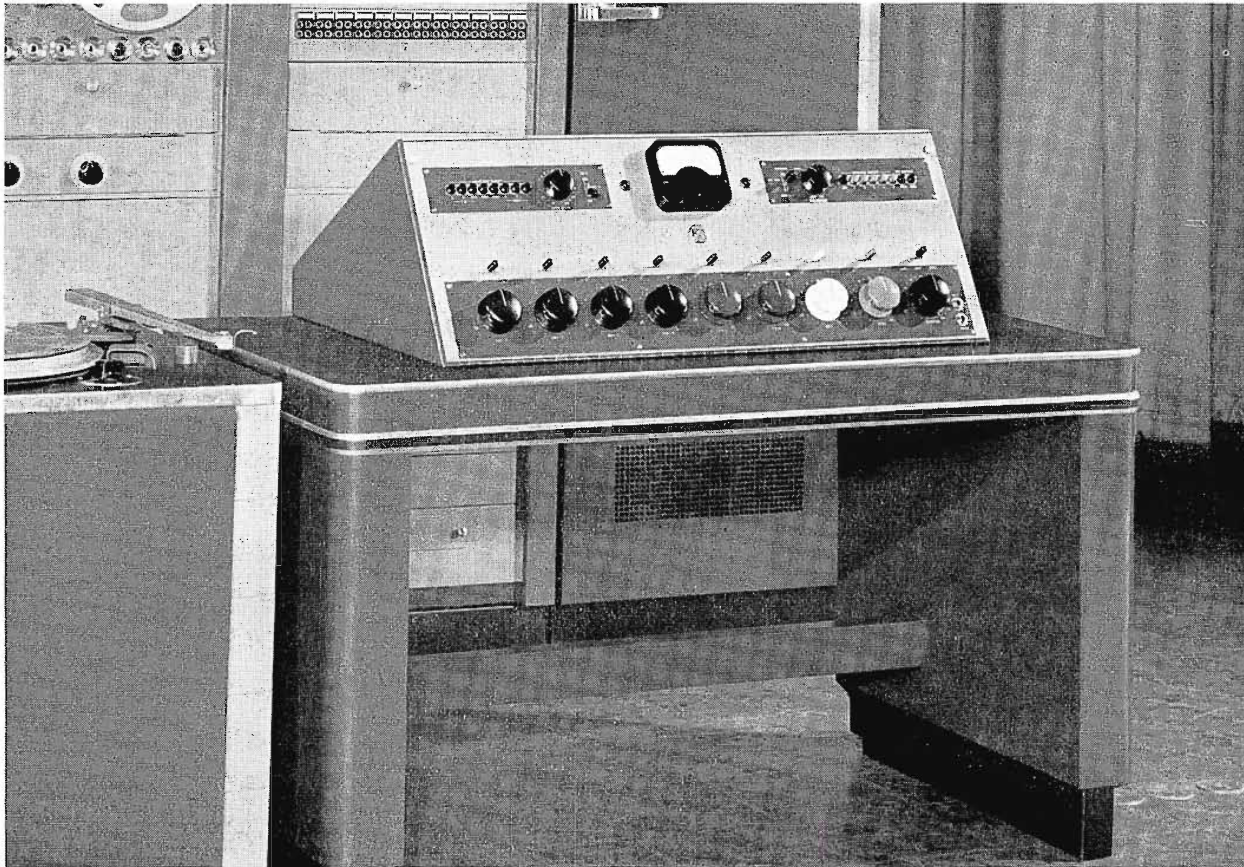

FIG. 1. View of the new BC-2B Studio Console mounted on a typical studio type desk. Visible at left is new Lightweight Pickup and Tone Arm—and at upper left the RT-11A Rack Mounted Tape Recorder.

TWO NEW STUDIO CONSOLETTES

Broadcasters attending the NAB Convention in Chicago this month will witness the unveiling of one of RCA's newest items, the Type BC-2B Console illustrated here. For those not able to visit the convention, we offer a few high lights on this successor to the famous 76 Series of Consolettes. Full details of the BC-2B will appear in a later issue of BROADCAST NEWS.

The BC-2B is designed for operating convenience and ease of servicing, and offers a new concept of accessibility. The front panel tilts forward for easy access to all contacts, switches and gain controls. A removable top panel makes it possible to tilt the amplifier chassis back for amplifier maintenance. In addition, each amplifier is individually removable from the chassis.

Eight mixer positions are provided as shown in the photograph. The first four are high level microphone channels with provisions for switching two additional microphones into the fourth channel. Positions five and six are assigned to turn-

By
DAVID BAIN
Product Manager
Broadcast Audio Equipment

tables. Space and wiring are included in the console for an additional twin pre-amplifier in the turntable circuits. The seventh mixer is used for network, and the eighth for remotes. Push-button switches select five line inputs to the remote mixer. Colored knobs and switches tie related functions together.

High quality components are used throughout the BC-2B. Interlocked push-button switches are cam operated leaf type, assuring years of trouble-free operation. Improved fast relay circuits for speakers reduce the possibility of key clicks and audio feedback.

The amplifiers are of a new, compact design which utilizes low noise miniature tubes. The amplifier chassis are supported by rubber cushions to prevent transmission of vibration from the mounting frame to

the amplifier tubes. The mounting frame is pivoted to provide easy access to the wiring for service.

The pre-amplifiers have a gain of 40 db; two identical amplifiers are combined on a chassis. The program amplifier has a gain of 92 db and a maximum output level of 22 dbm to 600-ohm line after a 6 db pad. The monitor amplifier has a gain of 110 db which is sufficient to drive the monitor speakers directly from a microphone. The monitor amplifier may also be used in emergencies as a line amplifier if the program amplifier should fail.

The frequency response from any input to the line output is within ± 1 db from 30 to 15,000 cps. The total rms harmonic distortion is less than .5% from 50 to 15,000 cps at a line output level of 18 dbm. Pin jacks are provided in the cathode circuit of each amplifier stage for checking tube current.

The power supply is a separate unit contained in a cabinet which may be wall or rack mounted, and it consists of two inde-

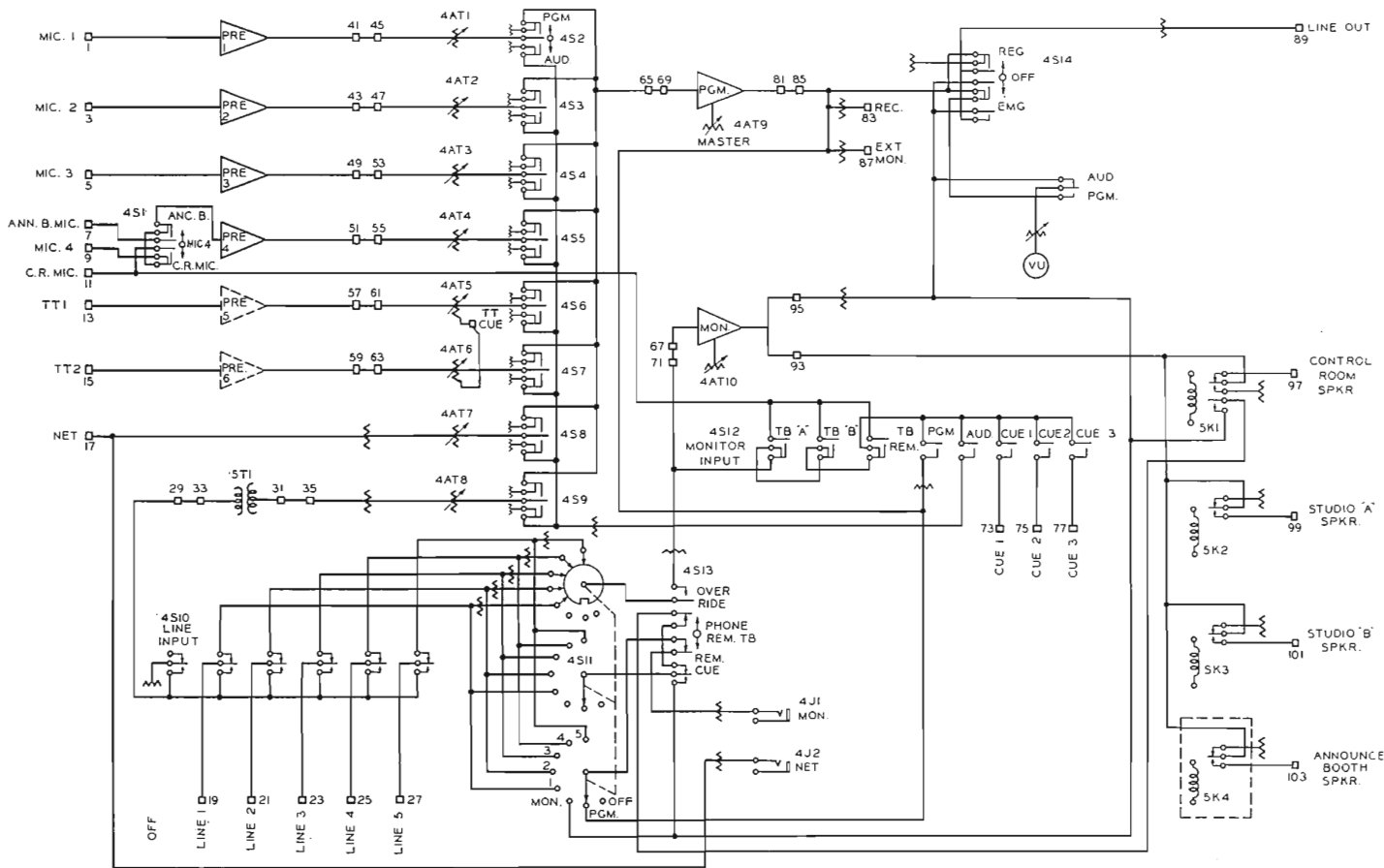

FIG. 2. Simplified block circuit diagram of the BC-2B Console.

pendent circuits; one to supply power to the amplifiers, the other to the relays. The components, such as transformer, rectifier and filters, are mounted on a hinged chassis to provide access for installation and service. The total power input required

is only 150 watts, 50 to 60 cps a-c at 100 to 130 volts.

Considerable thought has been given to the styling of the BC-2B, resulting in a design which is compatible with both audio and television practices. Its low height and

sloping back give improved visibility into studios. Watch for complete details on the BC-2B Console in a later issue of BROADCAST NEWS. Meanwhile, call on your RCA Field Representative for further information.

FIG. 3. Closeup view of the BC-2B Console which provides eight mixer positions. Colored knobs and switches enable quick identification of related functions (see cover photo).

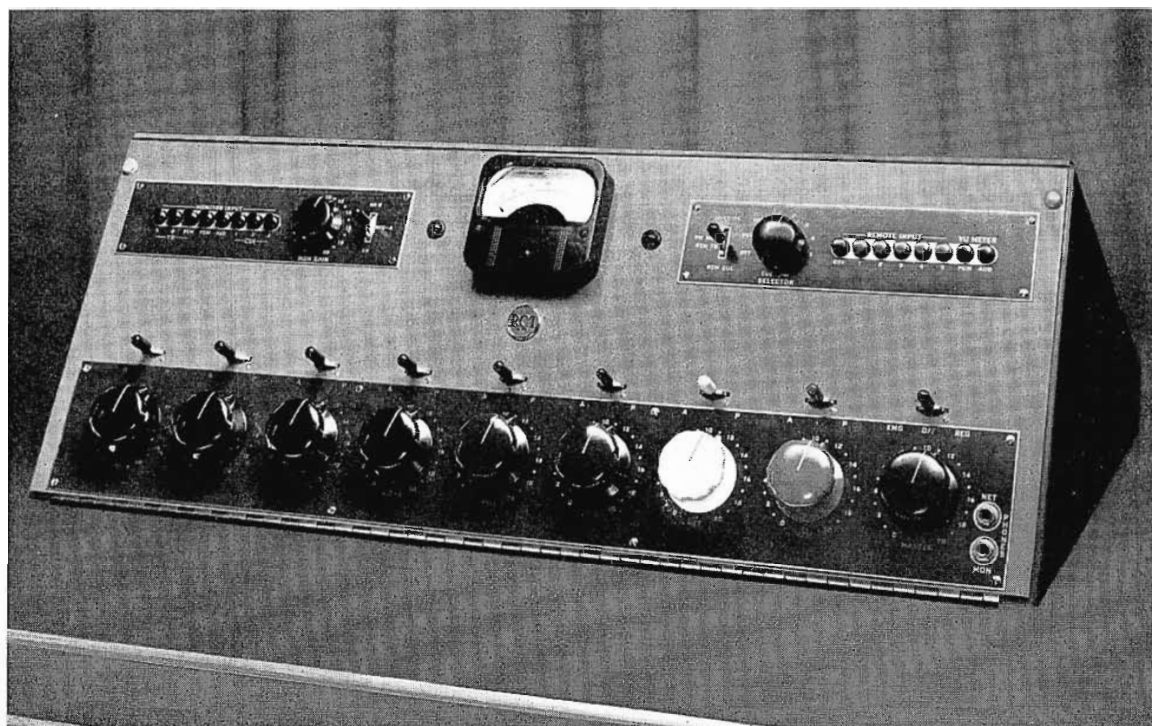

New "Semi-Custom" Switching Console

Another new Broadcast Audio Product on display at the NAB Convention this month is the BCS-11A Master Switching Console. From a design and operating standpoint, the new Console can be described best as a "semi-custom" equipment—since it combines many basic functions normally found in custom master control units. As a result of this similarity, the BCS-11A provides greatly increased flexibility when used with Broadcast Studio Consoles.

The BCS-11A is styled to match the BC-2B Studio Console in shape and appearance, and may be installed for "side-by-side" operation. As used in these combinations, the BCS-11A makes possible a convenient, central master-studio control, utilizes existing studio consoles, and permits an economical desk-top installation.

The new Switching Console provides for the master control of ten program sources to three outgoing lines. It is designed with stepping relays and provides pre-set program source selection for all outgoing channels. All three outgoing channels may be used on any one program source. A local-master selector switch for each outgoing channel permits either individual or collective switching of all channels.

The complete switching facilities of the BCS-11A are enclosed within a single, compact unit except for an external relay power supply. Easy access to all com-

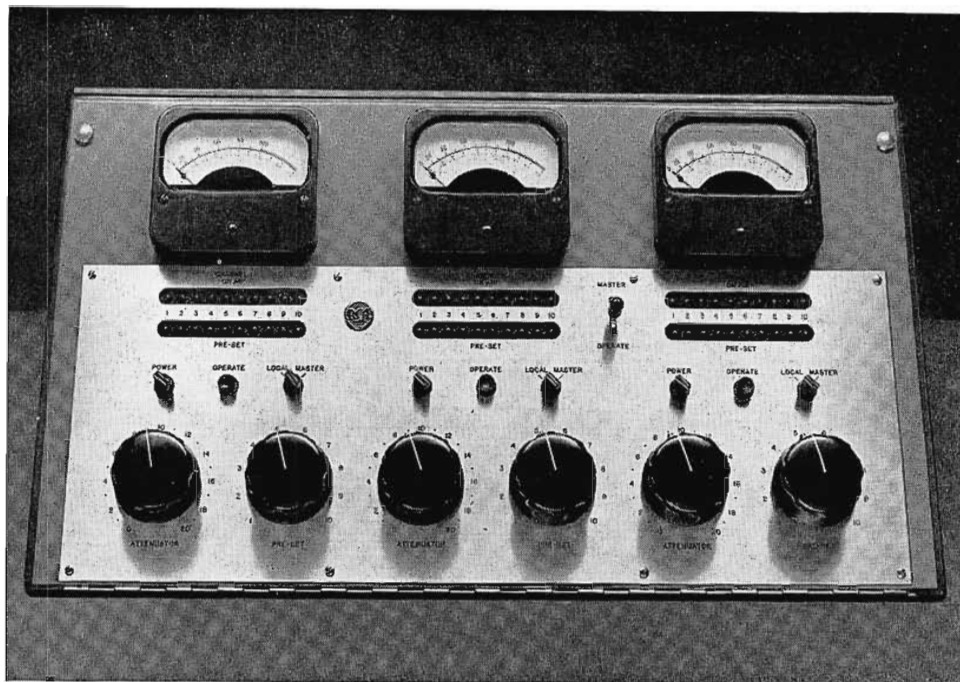

FIG. 4. The new BCS-11A Master Switching Console which combines many functions normally found in custom audio equipment.

ponents is permitted by a removable top panel and a hinged front panel.

Since it is not intended to completely cover the features and operation of the ECS-11A in this description, a more detailed article is being planned for a forthcoming issue of BROADCAST NEWS. Therefore, in addition to the preceding description, various technical operating features and services performed by the BCS-11A are enumerated below for ready reference.

1. An operate button for each outgoing channel and a master operate button

activate all outgoing channels simultaneously.

2. Bridging input permits operation from any audio line 600-ohms or lower.
3. A power switch for each channel turns off all relay power to that channel without disturbing the switching arrangement.
4. Illuminated VU meters are provided for each outgoing channel. The VU meter lamps are activated by the channel power switch and serve as a pilot lamp indicating an active channel.



FIG. 5. The appearance and shape of the BCS-11A makes it ideal for "side-by-side" operation with the Console to provide a convenient master-studio control setup.

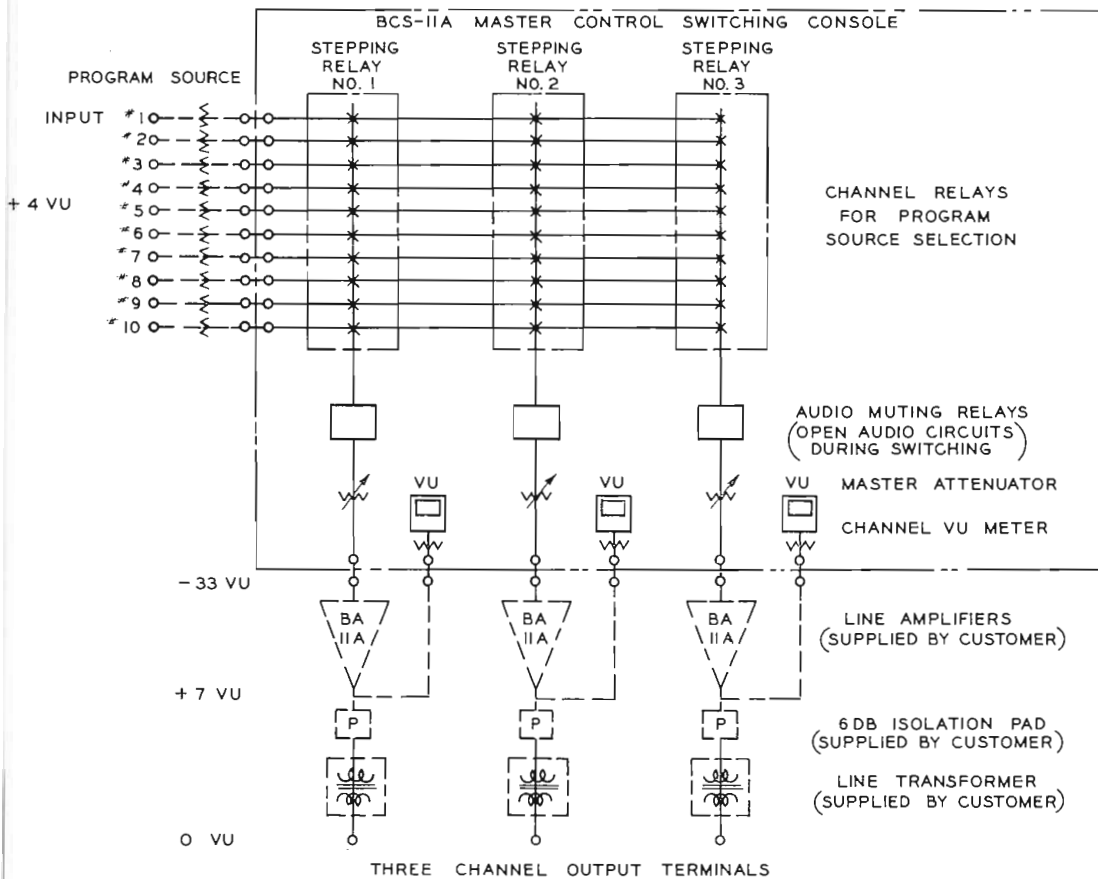

FIG. 6. Block circuit diagram of the BCS-11A which has complete facilities for the switching of up to ten program sources to three outgoing channels.

5. Indicator lamps for each outgoing channel show the "pre-set" studio and the "on-air" program source for that channel.
6. Switching facilities for each outgoing channel (which provide for "pre-set" and "on-air" indicator lamps at the remote program source location) show its switching status.
7. Provision is made for using the "line key" at the program source to interlock the "on-air" indicator lamps at both the switching location and the program source.
8. A master attenuator is provided for each outgoing channel.
9. Line selector switching is accomplished with telephone type stepping relays. Solid silver contacts are used for all audio circuits to provide optimum wear and long service.
10. A relay power failure will not remove program from the air. The return of power after a failure does not change the program switching.
11. Space for line transformers or fixed attenuators is provided within the console.
12. Provision for adjustment of VU meter range.



Field Engineering Service to Broadcasters...AM, FM, TV

RCA Service Company engineers are experienced in all the latest techniques and are equipped with the most modern specialized measuring equipment. The RCA Service Company has been working hand in hand with the nation's broadcasters for over 25 years.

OUR SERVICE TO BROADCASTERS...

- Installation supervision and measurements of transmitting, studio and accessory equipment . . . AM, FM or TV.
 - Instruction and training of station operating personnel.
 - Measurement and curves on FM and TV antennas and accessory equipment, including transmission lines, matching networks, diplexers.
 - Prompt help in emergencies. Technical advice, service, and assistance on special problems.
 - Performance measurements and adjustments for station compliance with FCC regulations.
- For further information call or write Communications Service Section, RCA Service Company, Inc., Camden, N. J.
(For service outside the U. S. A., consult your Authorized RCA Distributor)

NOW—restore the original quality of your RCA microphones, transcription pick-ups and test and measuring equipment under the new Factory-Reconditioning Plan. For complete details, write: Return Apparatus Control, Building 8-2, Camden, N. J.



RCA Service Company, Inc.
 A Subsidiary of the Radio Corporation of America
 CAMDEN, NEW JERSEY

It plays—45's, 33 $\frac{1}{3}$ fine-grooves', 33 $\frac{1}{3}$ standards', 78 standards'



The All-New RCA Pick-up and Tone Arm installed on a 70-D turntable.

HIGH-FIDELITY PICK-UP...one arm, all speeds!

RCA's All-New Tone Arm—with magnetic lateral plug-in heads—fits all standard turntables. Only two heads are needed for all speeds.

This versatile pick-up and tone arm combination... installed on your turntable... can play every record and transcription in your library. *Just plug in the head for the right record groove—and spin the platter.* It's as easy as that.

Designed for studio-quality at all standard speeds, this unique system has outstanding features over previous types. For instance, plug-in magnetic heads need no adjustments for stylus pressure. Visibility of the stylus (from the top of the head) permits accurate groove-spotting.

Anti-friction pivots and low inertia provide easy tracking on eccentric and warped records. Lower weight assures better record service—longer stylus life. Tracking error of the arm is less than 4 degrees.

Arm assembly MI-11885 is complete with tone arm, mounting plate, hardware, and the filter modification kit MI-11874 (for 70-series turntables).

You use plug-in head MI-11874-4 with the 1-mil stylus for fine-groove records. You use plug-in head MI-11874-5 with the 2 $\frac{1}{2}$ -mil stylus for standard transcriptions and 78 rpm records.

Order from your RCA Broadcast Sales Engineer, or direct from Dept. O-7, RCA Engineering Products, Camden, New Jersey.



AUDIO BROADCAST EQUIPMENT
RADIO CORPORATION of AMERICA
ENGINEERING PRODUCTS DEPARTMENT, CAMDEN, N. J.

In Canada: RCA VICTOR Company Limited, Montreal



Good-bye...
"ROLL-OVER"



Annoying "Roll-over"—starts up in TV sets when you mix remotes with locals



Good-bye "Roll-over"! The RCA TV GENLOCK tightly locks your local and remote sync generators together—instantaneously and automatically.

RCA's TV Genlock TG-45 ends picture slipping when you "lap dissolve" and "superimpose."

Now you can lock two entirely different programs together—remote or local—and hold pictures steady *right through switching!* No manual adjustments of phasing to fiddle with. No extra equipment needed at remote pick-up points. Here's how the GENLOCK works.

Located in your main studio, this simple unit compares the signal of your remote sync generator with the signal of your local sync generator. The difference in the phasing of the pulses produces an "error" signal which locks your local generator as a "slave" to your remote generator as a master. This enables you to treat remote signals as local signals—and switch back and forth without picture "roll-over," *no matter where your program originates!*

The RCA GENLOCK is simple in design, completely automatic in operation—"locks-in" much faster than you can switch. It fits any standard 19-inch TV rack.

Give your programming a lift. Switch as you please between programs for variety and for special effects. It's easy with a GENLOCK. For more information call your RCA TV equipment representative. Or write Dept. 19AE, RCA Engineering Products, Camden, N. J.

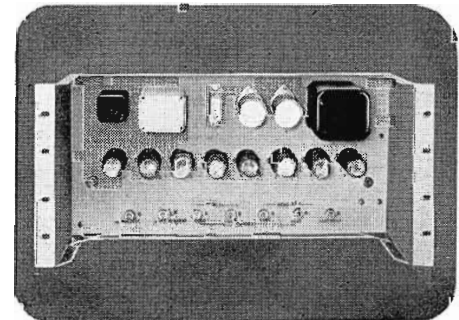

RCA GENLOCK, Type TG-45. This is the simple, automatic system that electrically locks two separate television pick-up systems together.



TELEVISION BROADCAST EQUIPMENT
RADIO CORPORATION of AMERICA
ENGINEERING PRODUCTS DEPARTMENT, CAMDEN, N. J.

In Canada: RCA VICTOR Company Limited, Montreal

RCA TELEVISION

First choice of ALL the Americas!

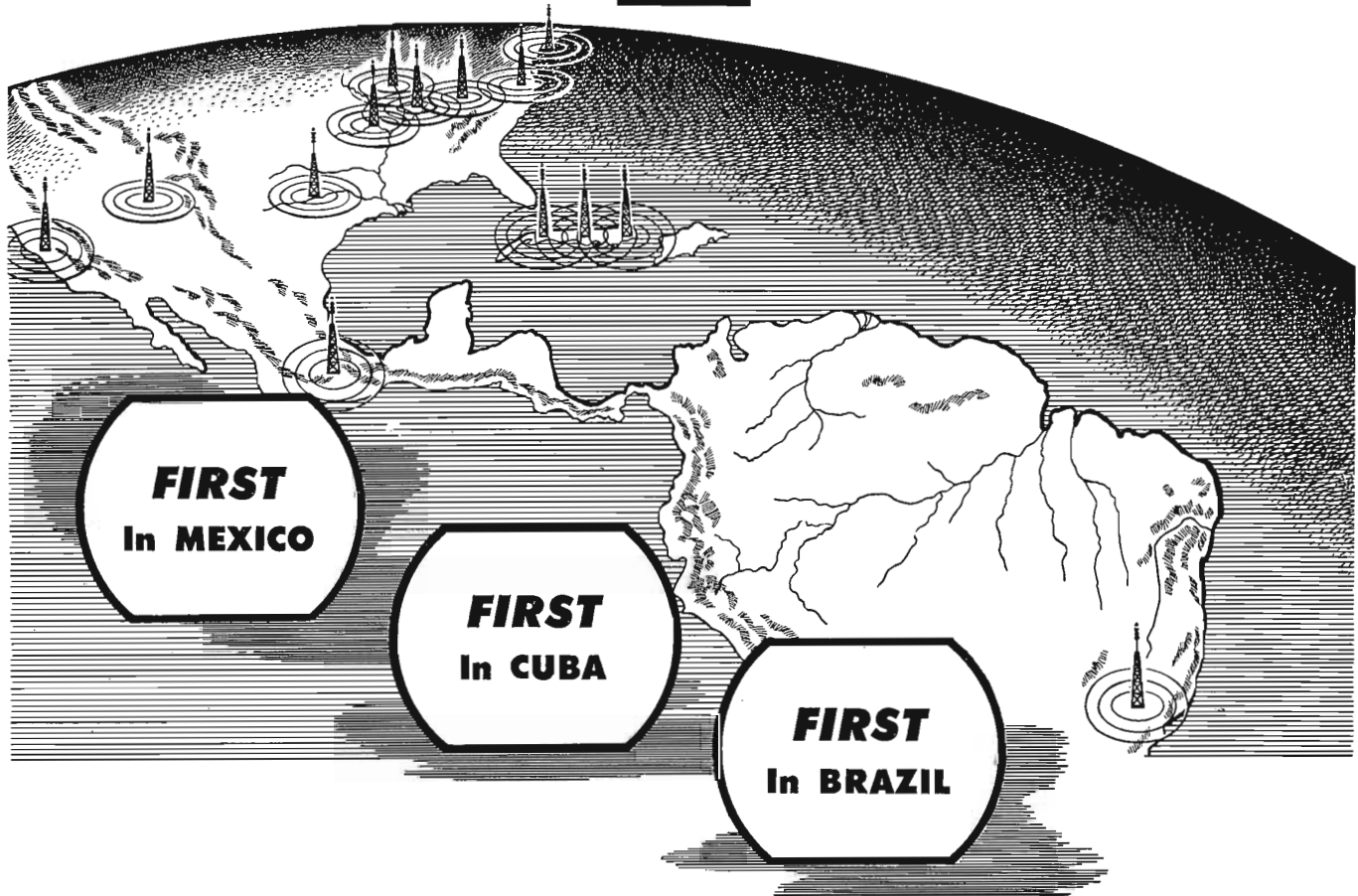

RCA is proud to welcome Mexico, Cuba, and Brazil—their great audience, and their great creative talents—into the family of RCA Television. The first stations to bring video programs to Mexico, Cuba, and Brazil are completely RCA equipped.

In the United States of America, the great *majority* of television stations have installed RCA transmitters and associated equipment. RCA is the first choice of *all* the Americas.

Television, the new teacher, is helping to train and to educate, as well as to entertain.

Your RCA Distributor will be glad to keep you fully informed on

RCA television and its great possibilities in the economy and the culture of your country.

RCA salutes Latin America's pioneers in television:

BRAZIL

PRF3TV—Emissoras Associadas
São Paulo

CUBA

Union Radio, Havana
CMQ—Havana
Telenews Co., Alonso, S.A.*, Havana

MEXICO

XHTV—Television de Mexico, S.A.,
Mexico, D.F.



More than a million RCA TV Receivers are in use in homes in the U.S.A.

RCA television receivers inherit the manufacturing and design experience poured by RCA into the more than 1,000,000 RCA television sets now in use in the U.S.A. More than 20 years of experience and \$50,000,000 in video research have made RCA quality and performance the finest in television.

*Under construction



RCA INTERNATIONAL DIVISION
RADIO CORPORATION of AMERICA
RCA BUILDING
30 ROCKEFELLER PLAZA, NEW YORK, N.Y., U.S.A.

World Leader in Radio . . . First in Sound . . . First in Television

RCA's new "400" Junior

Lightweight (Complete Single-Case Portable)

16mm Sound Movie Projector

The new "400" Junior has all the features you have looked for in a 16mm sound projector. It is compact and portable. Speaker in lift-off cover, projector, and connecting cables are all contained in an attractive lightweight, single-case unit.

Easy and quick to set up. So simple to

thread, even a child can do it. Pictures at their best in brilliance and contrast. Sound reproduced with dramatic realism and full tonal range. Meets every requirement of fully professional quality. Priced within limited budget requirements of schools, churches, business and industry.

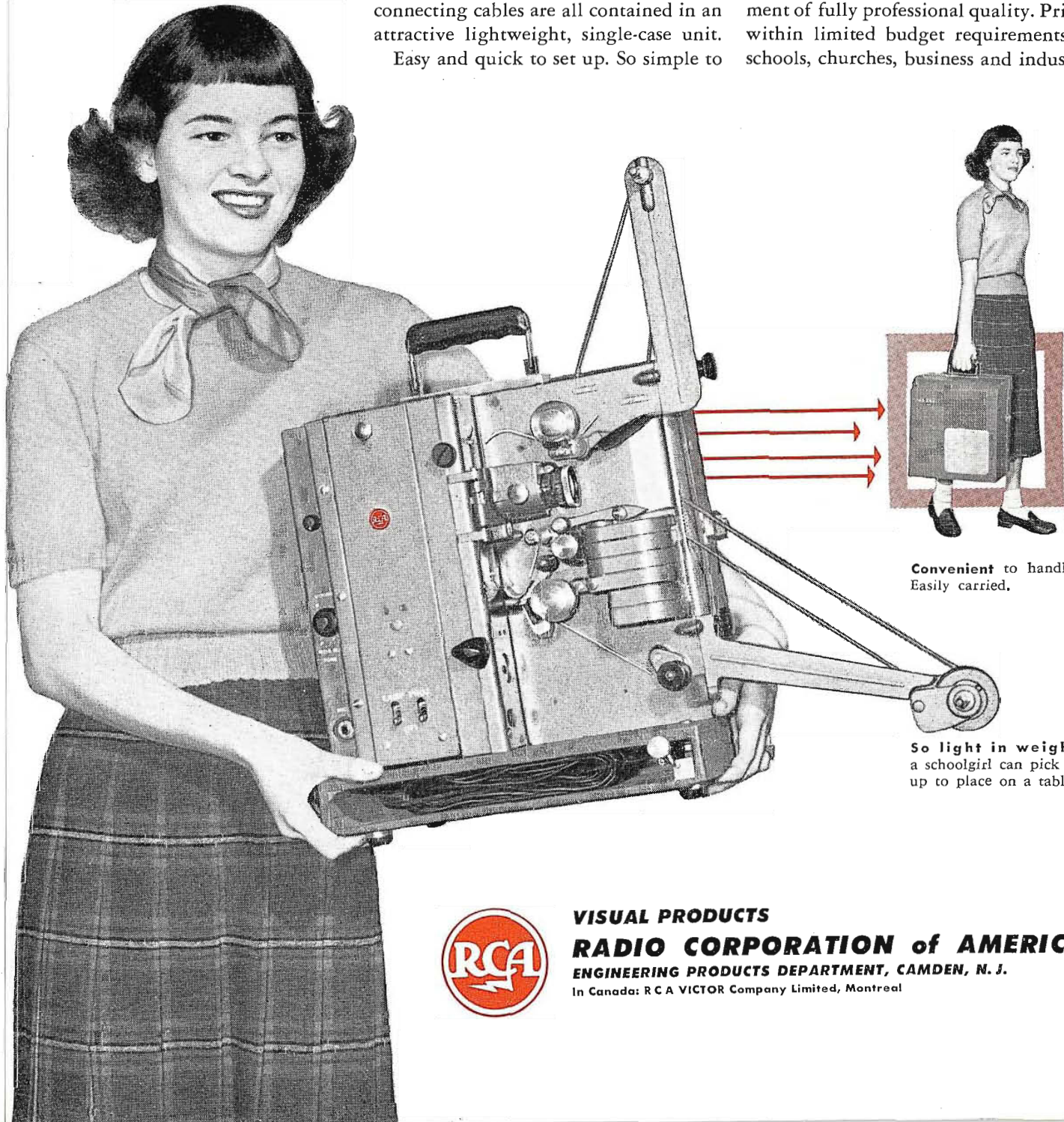

Convenient to handle.
Easily carried.

So light in weight
a schoolgirl can pick it
up to place on a table.



VISUAL PRODUCTS

RADIO CORPORATION of AMERICA

ENGINEERING PRODUCTS DEPARTMENT, CAMDEN, N. J.

In Canada: R C A VICTOR Company Limited, Montreal

WGAR

says...



RCA-5671's—the high-power triodes with thoriated-tungsten filaments.

For unusual economy and long life . . . use RCA thoriated-tungsten filament tubes

The remarkable performance of RCA-5671's at WGAR illustrates the reliability of RCA thoriated-tungsten filament construction in power tubes for broadcast and industrial services.

In addition to providing long life and dependability, the RCA thoriated-tungsten filament in the 5671 consumes 60 per cent less power than a conventional pure-tungsten filament . . . making possible savings of \$1300 or more a year in filament power alone in a typical 50-kw AM transmitter!

The RCA-5671 now employs an improved, lighter-weight radiator that reduces the weight of the tube by about 100

*AS OF JAN. 1, 1951

pounds. The new radiator fits the same air jacket as used for the former radiator.

RCA-developed thoriated-tungsten filaments are also used in types 5762, 5770, 5771, 5786, and 5831 for broadcast and industrial services, resulting in dependable performance and substantial savings in filament power.

To get all the performance and life you pay for . . . buy RCA tubes. They're available from your local **RCA Tube Distributor** or direct from RCA. For technical information on any of these types, write RCA, Commercial Engineering, Section 36DP, Harrison, New Jersey.

THE FOUNTAINHEAD OF MODERN TUBE DEVELOPMENT IS RCA



RADIO CORPORATION of AMERICA
ELECTRON TUBES
HARRISON, N. J.